

FOREWORD

This wiring diagram manual has been prepared to provide information on the electrical system of the 1999 GS 400 / GS 300.

Applicable models: UZS160 Series
JZS160 Series

For service specifications and repair procedures of the above models other than those listed in this manual, refer to the following manuals;

Manual Name	Pub. No.
● 1999 LEXUS GS 400 / GS 300 Repair Manual	RM665U1 RM665U2
● 1999 LEXUS GS 400 / GS 300 New Car Features	NCF161U

All information in this manual is based on the latest product information at the time of publication. However, specifications and procedures are subject to change without notice.

TOYOTA MOTOR CORPORATION

NOTICE

When handling supplemental restraint system components (removal, installation or inspection, etc.), always follow the direction given in the repair manuals listed above to prevent accidents and supplemental restraint system malfunction.

A INTRODUCTION

This manual consists of the following 12 sections:

No.	Section	Description
A	INDEX	Index of the contents of this manual.
	INTRODUCTION	Brief explanation of each section.
B	HOW TO USE THIS MANUAL	Instructions on how to use this manual.
C	TROUBLE-SHOOTING	Describes the basic inspection procedures for electrical circuits.
D	ABBREVIATIONS	Defines the abbreviations used in this manual.
E	GLOSSARY OF TERMS AND SYMBOLS	Defines the symbols and functions of major parts.
F	RELAY LOCATIONS	Shows position of the Electronic Control Unit, Relays, Relay Block, etc. This section is closely related to the system circuit.
G	ELECTRICAL WIRING ROUTING	Describes position of Parts Connectors, Splice points, Ground points, etc. This section is closely related to the system circuit.
H	INDEX	Index of the system circuits.
	SYSTEM CIRCUITS	Electrical circuits of each system are shown from the power supply through ground points. Wiring connections and their positions are shown and classified by code according to the connection method. (Refer to the section, "How to use this manual"). The "System Outline" and "Service Hints" useful for troubleshooting are also contained in this section.
I	GROUND POINTS	Shows ground positions of all parts described in this manual.
J	OVERALL ELECTRICAL WIRING DIAGRAM	Provides circuit diagrams showing the circuit connections.
K	POWER SOURCE (Current Flow Chart)	Describes power distribution from the power supply to various electrical loads.
L	PART NUMBER OF CONNECTORS	Indicates the part number of the connectors used in this manual.

HOW TO USE THIS MANUAL B

This manual provides information on the electrical circuits installed on vehicles by dividing them into a circuit for each system.

The actual wiring of each system circuit is shown from the point where the power source is received from the battery as far as each ground point. (All circuit diagrams are shown with the switches in the OFF position.)

When troubleshooting any problem, first understand the operation of the circuit where the problem was detected (see System Circuit section), the power source supplying power to that circuit (see Power Source section), and the ground points (see Ground Points section). See the System Outline to understand the circuit operation.

When the circuit operation is understood, begin troubleshooting of the problem circuit to isolate the cause. Use Relay Location and Electrical Wiring Routing sections to find each part, junction block and wiring harness connectors, wiring harness and wiring harness connectors, splice points, and ground points of each system circuit. Internal wiring for each junction block is also provided for better understanding of connection within a junction block.

Wiring related to each system is indicated in each system circuit by arrows (from__, to__). When overall connections are required, see the Overall Electrical Wiring Diagram at the end of this manual.

B HOW TO USE THIS MANUAL

* The system shown here is an EXAMPLE ONLY. It is different to the actual circuit shown in the SYSTEM CIRCUITS SECTION.

[A] STOP LIGHT

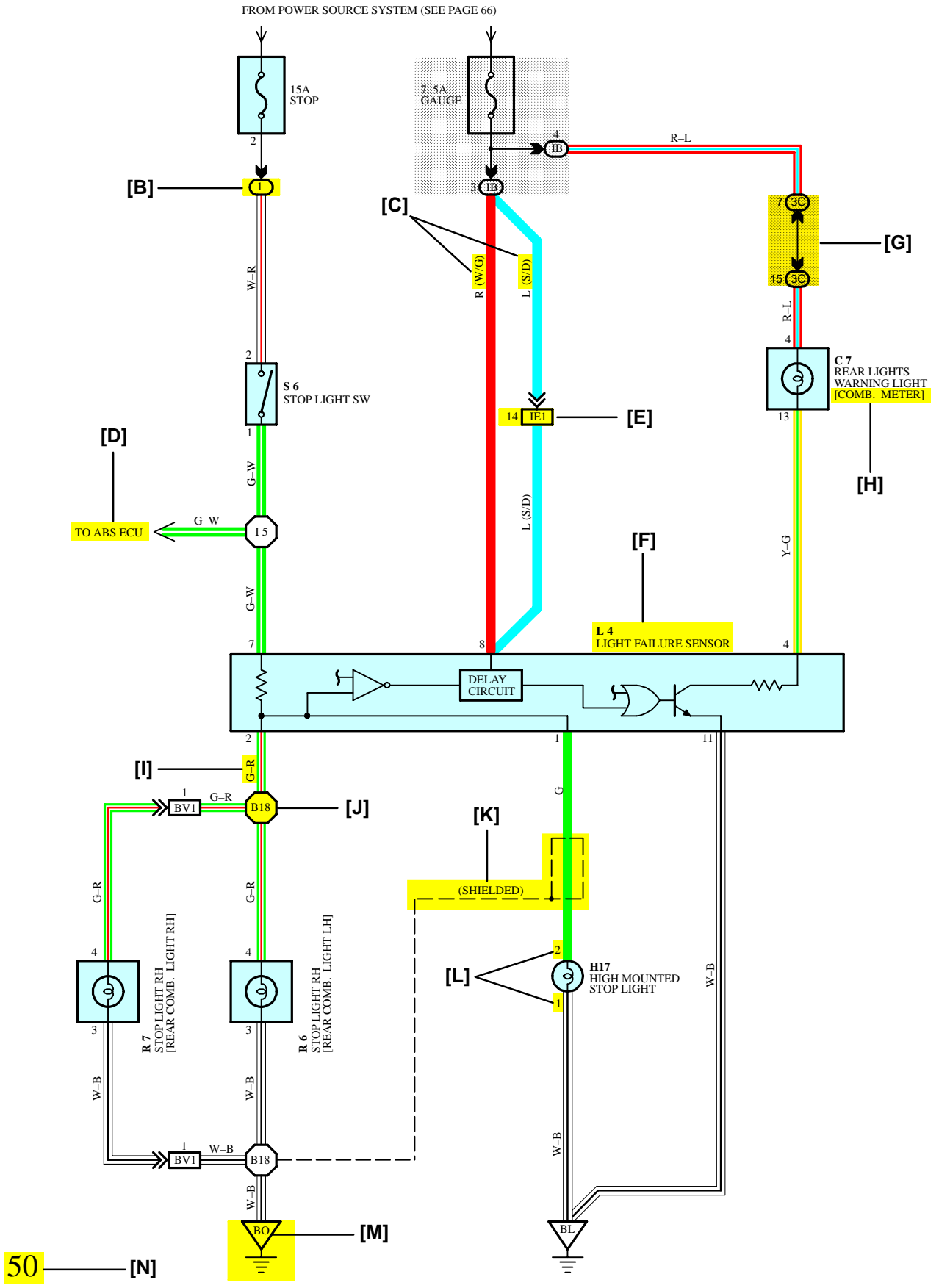

[A] : System Title

[B] : Indicates a Relay Block. No shading is used and only the Relay Block No. is shown to distinguish it from the J/B

Example : ① Indicates Relay Block No.1

[C] : () is used to indicate different wiring and connector, etc. when the vehicle model, engine type, or specification is different.

[D] : Indicates related system.

[E] : Indicates the wiring harness and wiring harness connector. The wiring harness with male terminal is shown with arrows (↗). Outside numerals are pin numbers.

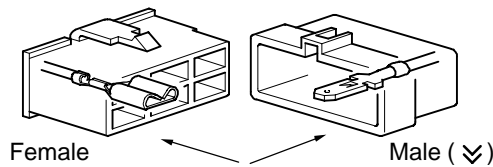

The first letter of the code for each wiring harness and wiring harness connector(s) indicates the component's location, e.g, "E" for the Engine Compartment, "I" for the Instrument Panel and Surrounding area, and "B" for the Body and Surrounding area.

When more than one code has the first and second letters in common, followed by numbers (e.g, IH1, IH2), this indicates the same type of wiring harness and wiring harness connector.

[F] : Represents a part (all parts are shown in sky blue). The code is the same as the code used in parts position.

[G] : Junction Block (The number in the circle is the J/B No. and the connector code is shown beside it). Junction Blocks are shaded to clearly separate them from other parts.

Example:

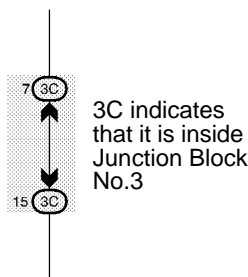

[H] : When 2 parts both use one connector in common, the parts connector name used in the wire routing section is shown in square brackets [] .

[I] : Indicates the wiring color.

Wire colors are indicated by an alphabetical code.

- B = Black W = White BR = Brown
- L = Blue V = Violet SB = Sky Blue
- R = Red O = Orange LG = Light Green
- P = Pink Y = Yellow GR = Gray
- G = Green

The first letter indicates the basic wire color and the second letter indicates the color of the stripe.

Example: L - Y

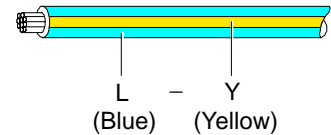

[J] : Indicates a wiring Splice Point (Codes are "E" for the Engine Room, "I" for the Instrument Panel, and "B" for the Body).

Example:

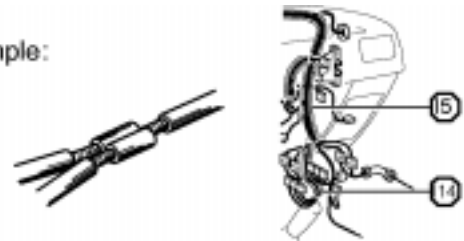

The Location of splice Point I 5 is indicated by the shaded section.

[K] : Indicates a shielded cable.



[L] : Indicates the pin number of the connector. The numbering system is different for female and male connectors.

Example : Numbered in order from upper left to lower right

Numbered in order from upper right to lower left

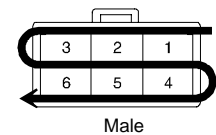
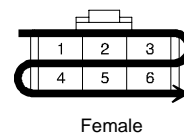

[M] : Indicates a ground point.

The first letter of the code for each ground point(s) indicates the component's location, e.g, "E" for the Engine Compartment, "I" for the Instrument Panel and Surrounding area, and "B" for the Body and Surrounding area.

[N] : Page No.

B HOW TO USE THIS MANUAL

[O] SYSTEM OUTLINE

Current is applied at all times through the STOP fuse to TERMINAL 2 of the stop light SW.
When the ignition SW is turned on, current flows from the GAUGE fuse to TERMINAL 8 of the light failure sensor, and also flows through the rear lights warning light to TERMINAL 4 of the light failure sensor.

STOP LIGHT DISCONNECTION WARNING

When the ignition SW is turned on and the brake pedal is pressed (Stop light SW on), if the stop light circuit is open, the current flowing from TERMINAL 7 of the light failure sensor to TERMINALS 1, 2 changes, so the light failure sensor detects the disconnection and the warning circuit of the light failure sensor is activated.

As a result, the current flows from TERMINAL 4 of the light failure sensor to TERMINAL 11 to GROUND and turns the rear lights warning light on. By pressing the brake pedal, the current flowing to TERMINAL 8 of the light failure sensor keeps the warning circuit on and holds the warning light on until the ignition SW is turned off.

[P] SERVICE HINTS

S6 STOP LIGHT SW

2-1 : Closed with the brake pedal depressed

L4 LIGHT FAILURE SENSOR

1, 2, 7-GROUND : Approx. 12 volts with the stop light SW on

4, 8-GROUND : Approx. 12 volts with the ignition SW at ON position

11-GROUND : Always continuity

[Q] ○ : PARTS LOCATION

Code	See Page	Code	See Page	Code	See Page
C7	34	L4	36	R7	37
H17	36	R6	37	S6	35

[R] ○ : RELAY BLOCKS

Code	See Page	Relay Blocks (Relay Block Location)
1	18	R/B No.1 (Instrument Panel Left)

[S] ○ : JUNCTION BLOCK AND WIRE HARNESS CONNECTOR

Code	See Page	Junction Block and Wire Harness (Connector Location)
IB	20	Instrument Panel Wire and Instrument Panel J/B (Lower Finish Panel)
3C	22	Instrument Panel Wire and J/B No.3 (Instrument Panel Left Side)

[T] □ : CONNECTOR JOINING WIRE HARNESS AND WIRE HARNESS

Code	See Page	Joining Wire Harness and Wire Harness (Connector Location)
IE1	42	Floor Wire and Instrument Panel Wire (Left Kick Panel)
BV1	50	Luggage Room Wire and Floor Wire (Luggage Compartment Left)

[U] ▽ : GROUND POINTS

Code	See Page	Ground Points Location
BL	50	Under the Left Quarter Pillar
BO	50	Back Panel Center

[V] ○ : SPLICE POINTS

Code	See Page	Wire Harness with Splice Points	Code	See Page	Wire Harness with Splice Points
I5	44	Cowl Wire	B18	50	Luggage Room Wire

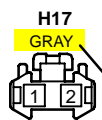
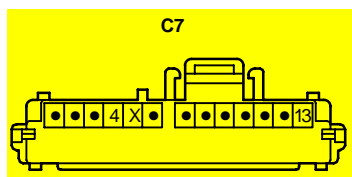

[X]

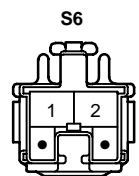
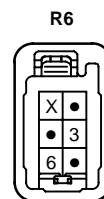
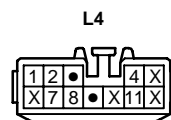

[O] : Explains the system outline.

[P] : Indicates values or explains the function for reference during troubleshooting.

[Q] : Indicates the reference page showing the position on the vehicle of the parts in the system circuit.

Example : Part "L4" (Light Failure Sensor) is on page 36 of the manual.

* The letter in the code is from the first letter of the part, and the number indicates its order in parts starting with that letter.

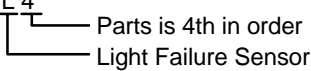
Example : L 4

[R] : Indicates the reference page showing the position on the vehicle of Relay Block Connectors in the system circuit.

Example : Connector "1" is described on page 18 of this manual and is installed on the left side of the instrument panel.

[S] : Indicates the reference page showing the position on the vehicle of J/B and Wire Harness in the system circuit.

Example : Connector "3C" connects the Instrument Panel Wire and J/B No.3. It is described on page 22 of this manual, and is installed on the instrument panel left side.

[T] : Indicates the reference page describing the wiring harness and wiring harness connector (the female wiring harness is shown first, followed by the male wiring harness).

Example : Connector "IE1" connects the floor wire (female) and Instrument panel wire (male). It is described on page 42 of this manual, and is installed on the left side kick panel.

[U] : Indicates the reference page showing the position of the ground points on the vehicle.

Example : Ground point "BO" is described on page 50 of this manual and is installed on the back panel center.

[V] : Indicates the reference page showing the position of the splice points on the vehicle.

Example : Splice point "I5" is on the Cowl Wire Harness and is described on page 44 of this manual.

[W]: Indicates connector to be connected to a part (the numeral indicates the pin No.) Explanation of pin use.

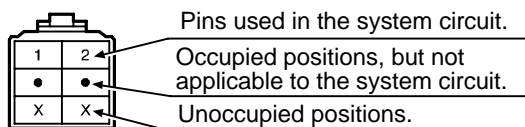

[X] : The pins shown are only for the highest grade, or only include those in the specification. Connectors not indicated are milky white in color.

HINT :

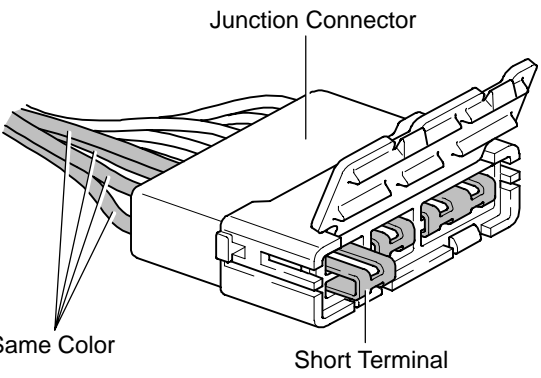

Junction Connector

Same Color

Short Terminal

Junction connector (code: J1 to J24) in this manual include a short terminal which is connected to a number of wire harnesses. Always perform inspection with the short terminal installed. (When installing the wire harnesses, the harnesses can be connected to any position within the short terminal grouping. Accordingly, in other vehicles, the same position in the short terminal may be connected to a wire harness from a different part.) Wire harness sharing the same short terminal grouping have the same color.

B HOW TO USE THIS MANUAL

The ground points circuit diagram shows the connections from all major parts to the respective ground points. When troubleshooting a faulty ground point, checking the system circuits which use a common ground may help you identify the problem ground quickly. The relationship between ground points (∇_{EA} , ∇_{IB} and ∇_{IC} shown below) can also be checked this way.

I GROUND POINT

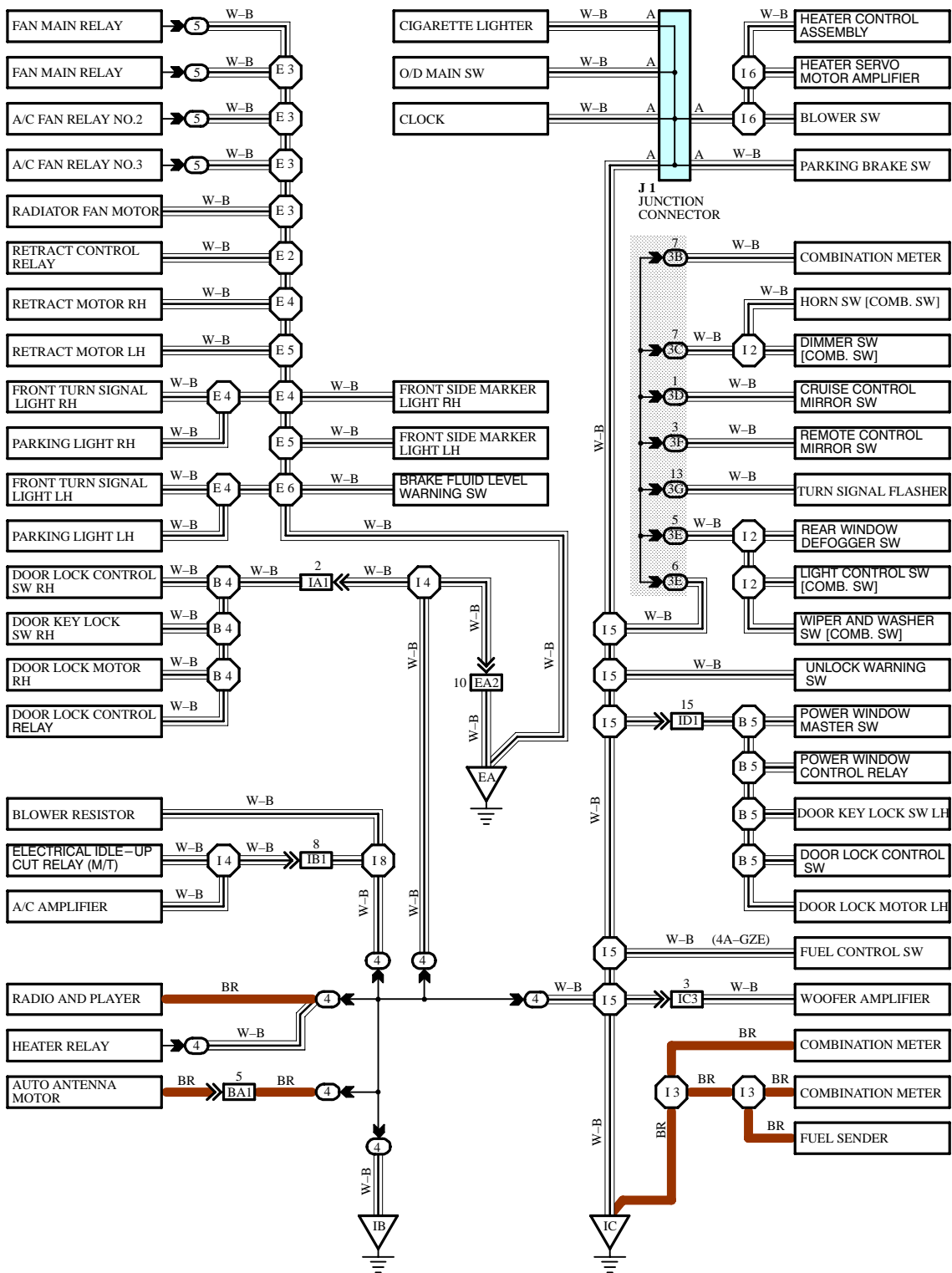

* The system shown here is an EXAMPLE ONLY. It is different to the actual circuit shown in the SYSTEM CIRCUITS SECTION.

The "Current Flow Chart" section, describes which parts each power source (fuses, fusible links, and circuit breakers) transmits current to. In the Power Source circuit diagram, the conditions when battery power is supplied to each system are explained. Since all System Circuit diagrams start from the power source, the power source system must be fully understood.

K POWER SOURCE (Current Flow Chart)

The chart below shows the route by which current flows from the battery to each electrical source (Fusible Link, Circuit Breaker, Fuse, etc.) and other parts.

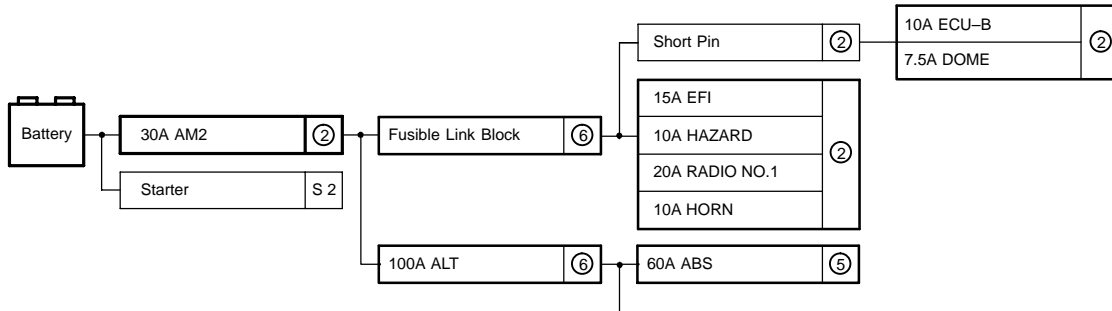

Engine Room R/B (See Page 20)

Fuse	System	Page	
20A	STOP	ABS	194
		ABS and Traction Control	187
		Cruise Control	180
		Electronically Controlled Transmission and A/T Indicator	166
		Multiplex Communication System	210
10A	DOME	Cigarette Lighter and Clock	214
		Combination Meter	230
		Headlight	112
		Interior Light	122
		Key Reminder and Seat Belt Warning	
		Light Auto Turn Off	

POWER SOURCE

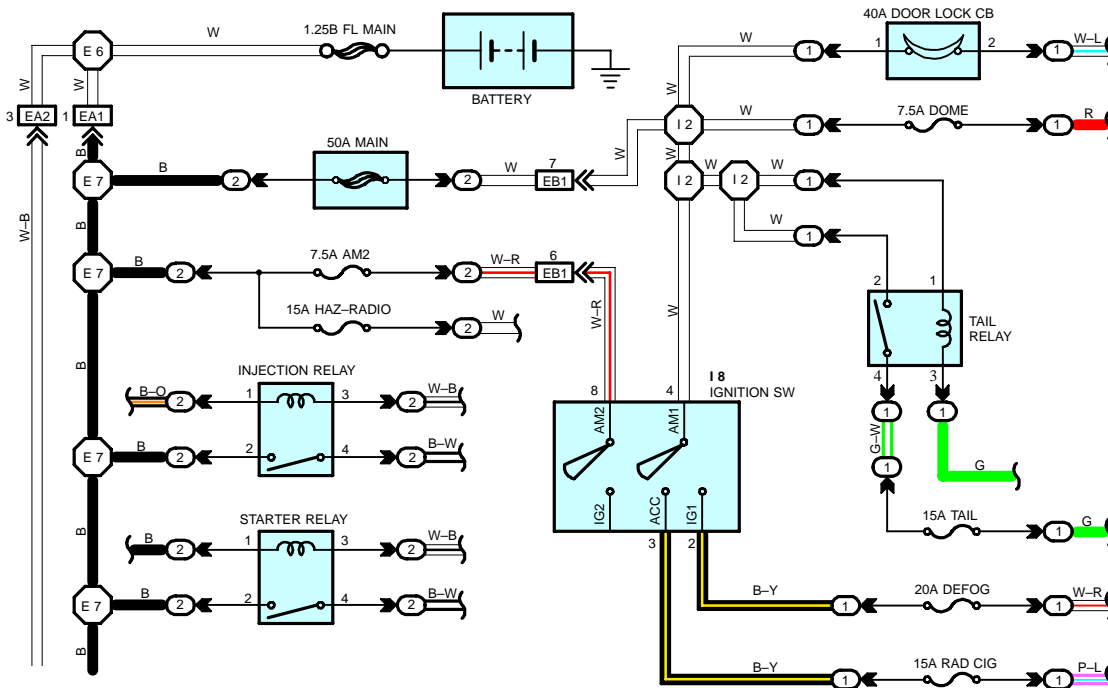

* The system shown here is an EXAMPLE ONLY. It is different to the actual circuit shown in the SYSTEM CIRCUITS SECTION.

C TROUBLESHOOTING

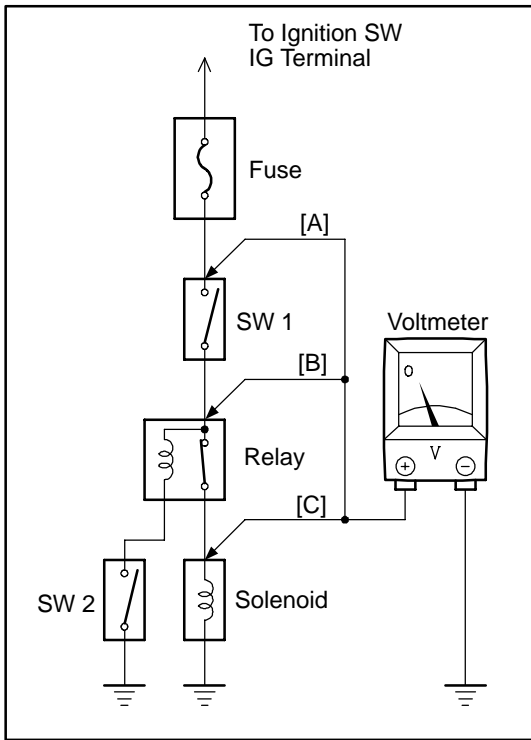

VOLTAGE CHECK

- (a) Establish conditions in which voltage is present at the check point.

Example:

- [A] – Ignition SW on
- [B] – Ignition SW and SW 1 on
- [C] – Ignition SW, SW 1 and Relay on (SW 2 off)

- (b) Using a voltmeter, connect the negative lead to a good ground point or negative battery terminal, and the positive lead to the connector or component terminal.

This check can be done with a test light instead of a voltmeter.

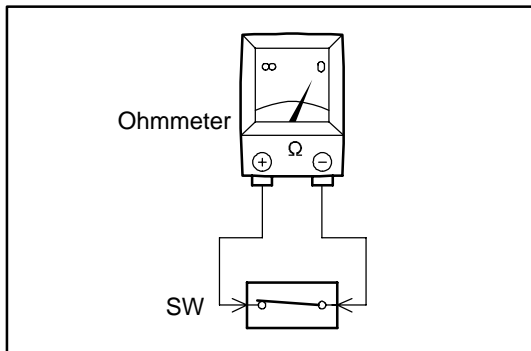

CONTINUITY AND RESISTANCE CHECK

- (a) Disconnect the battery terminal or wire so there is no voltage between the check points.
- (b) Contact the two leads of an ohmmeter to each of the check points.

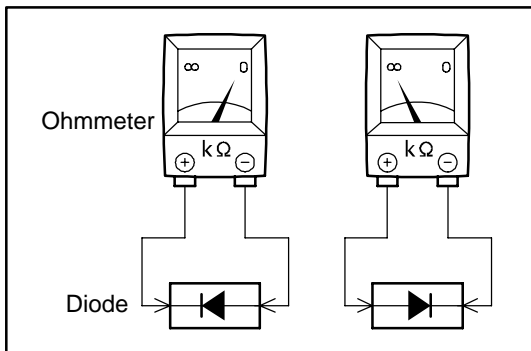

If the circuit has diodes, reverse the two leads and check again.

When contacting the negative lead to the diode positive side and the positive lead to the negative side, there should be continuity.

When contacting the two leads in reverse, there should be no continuity.

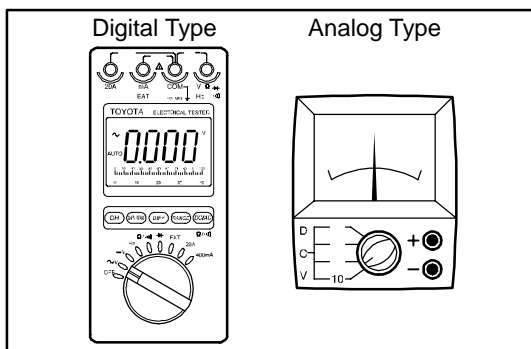

- (c) Use a volt/ohmmeter with high impedance (10 k Ω /V minimum) for troubleshooting of the electrical circuit.

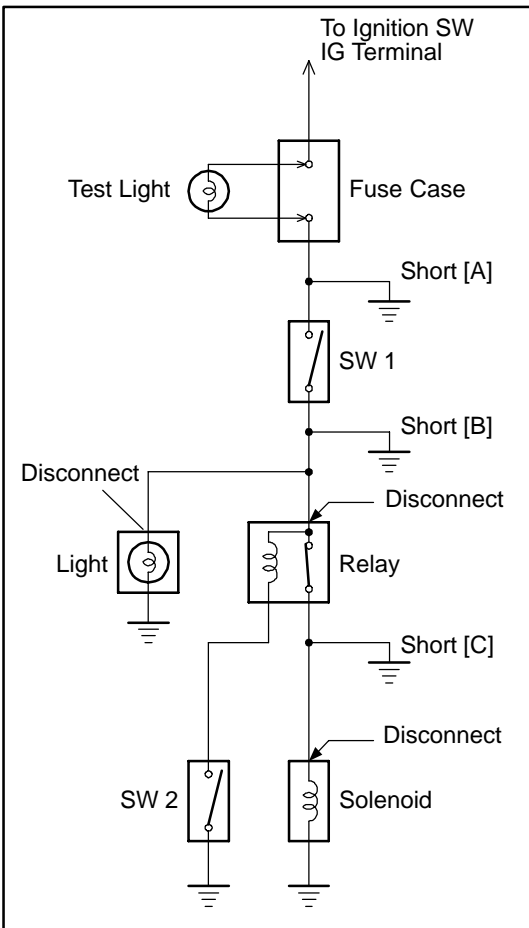

FINDING A SHORT CIRCUIT

- Remove the blown fuse and disconnect all loads of the fuse.
- Connect a test light in place of the fuse.
- Establish conditions in which the test light comes on.

Example:

- [A] – Ignition SW on
 - [B] – Ignition SW and SW 1 on
 - [C] – Ignition SW, SW 1 and Relay on (Connect the Relay) and SW 2 off (or Disconnect SW 2)
- Disconnect and reconnect the connectors while watching the test light. The short lies between the connector where the test light stays lit and the connector where the light goes out.
 - Find the exact location of the short by lightly shaking the problem wire along the body.

CAUTION:

- Do not open the cover or the case of the ECU unless absolutely necessary. (If the IC terminals are touched, the IC may be destroyed by static electricity.)
- When replacing the internal mechanism (ECU part) of the digital meter, be careful that no part of your body or clothing comes in contact with the terminals of leads from the IC, etc. of the replacement part (spare part).

DISCONNECTION OF MALE AND FEMALE CONNECTORS

To pull apart the connectors, pull on the connector itself, not the wire harness.

HINT: Check to see what kind of connector you are disconnecting before pulling apart.

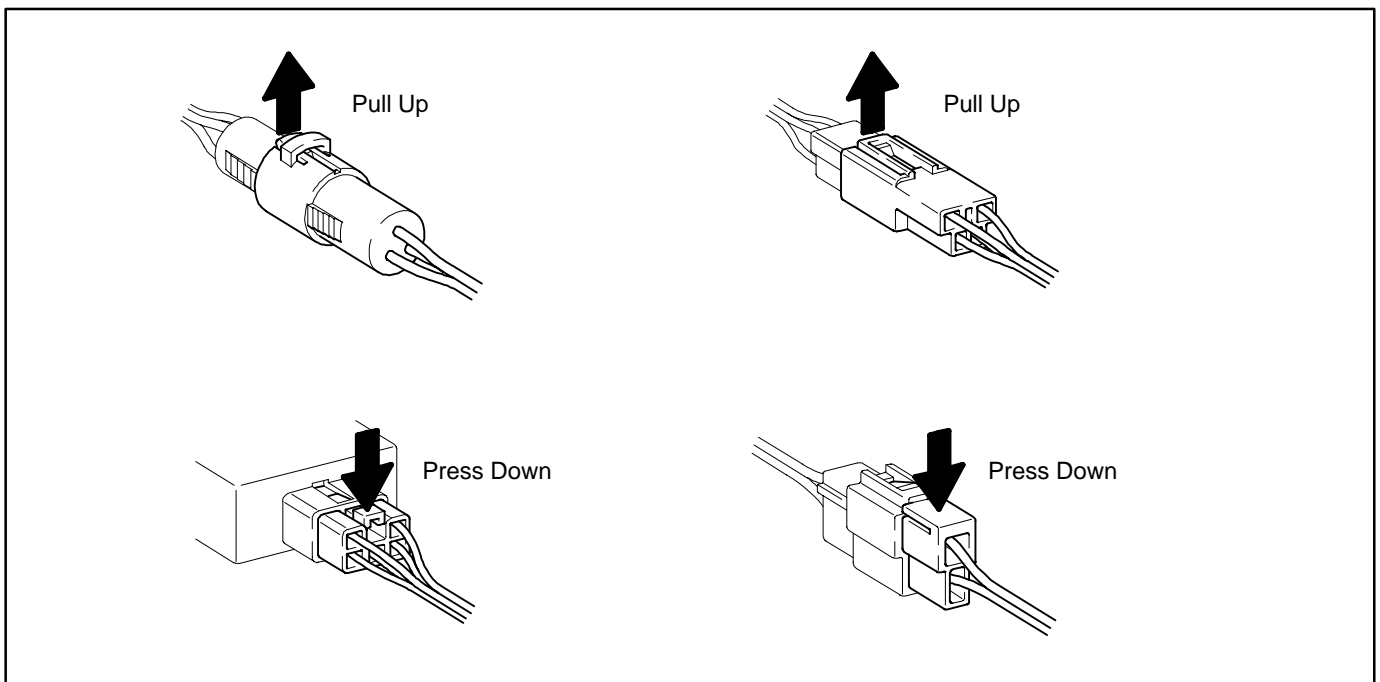

C TROUBLESHOOTING

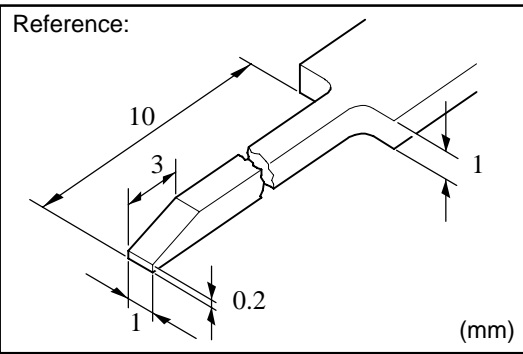

HOW TO REPLACE TERMINAL (with terminal retainer or secondary locking device)

1. PREPARE THE SPECIAL TOOL

HINT : To remove the terminal from the connector, please construct and use the special tool or like object shown on the left.

2. DISCONNECT CONNECTOR

3. DISENGAGE THE SECONDARY LOCKING DEVICE OR TERMINAL RETAINER.

(a) Locking device must be disengaged before the terminal locking clip can be released and the terminal removed from the connector.

(b) Use a special tool or the terminal pick to unlock the secondary locking device or terminal retainer.

NOTICE:

Do not remove the terminal retainer from connector body.

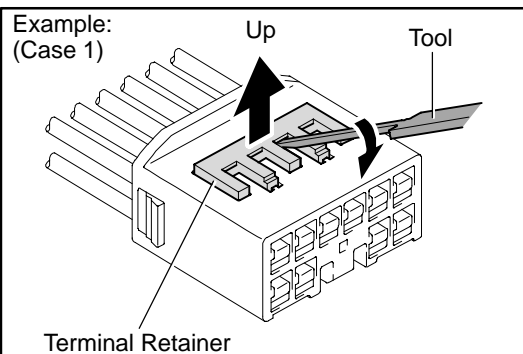

[A] For Non-Waterproof Type Connector

HINT : The needle insertion position varies according to the connector's shape (number of terminals etc.), so check the position before inserting it.

"Case 1"

Raise the terminal retainer up to the temporary lock position.

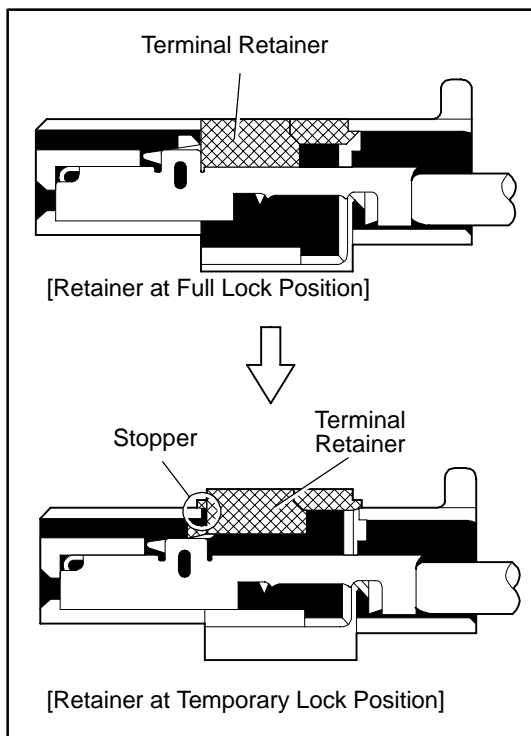

"Case 2"

Open the secondary locking device.

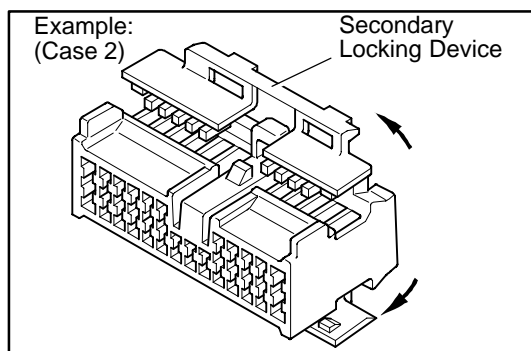

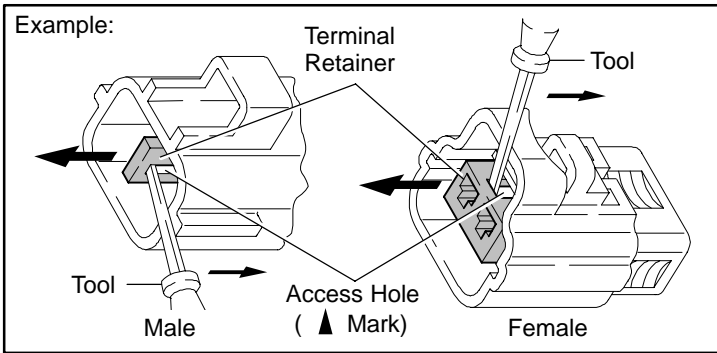
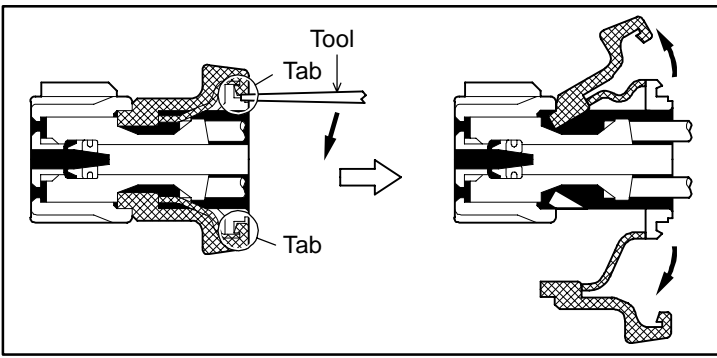

[B] For Waterproof Type Connector

HINT : Terminal retainer color is different according to connector body.

Example:

Terminal Retainer : Connector Body

Black or White : Gray

Black or White : Dark Gray

Gray or White : Black

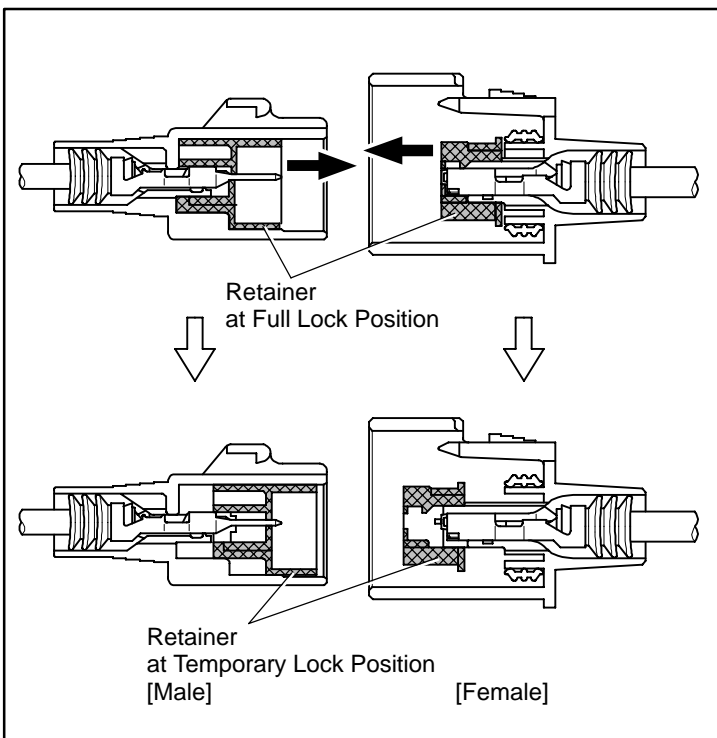

"Case 1"

Type where terminal retainer is pulled up to the temporary lock position (Pull Type).

Insert the special tool into the terminal retainer access hole (▲Mark) and pull the terminal retainer up to the temporary lock position.

HINT : The needle insertion position varies according to the connector's shape (Number of terminals etc.), so check the position before inserting it.

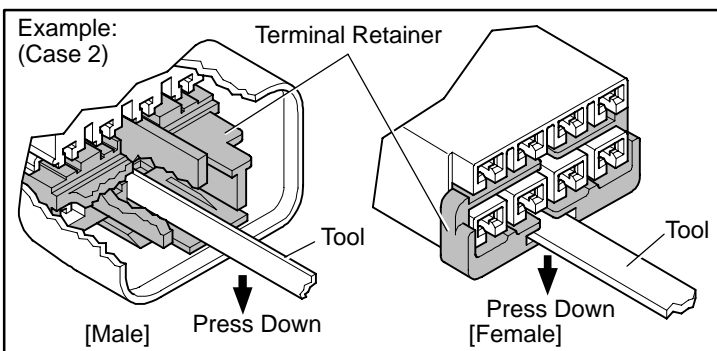

"Case 2"

Type which cannot be pulled as far as Power Lock insert the tool straight into the access hole of terminal retainer as shown.

C TROUBLESHOOTING

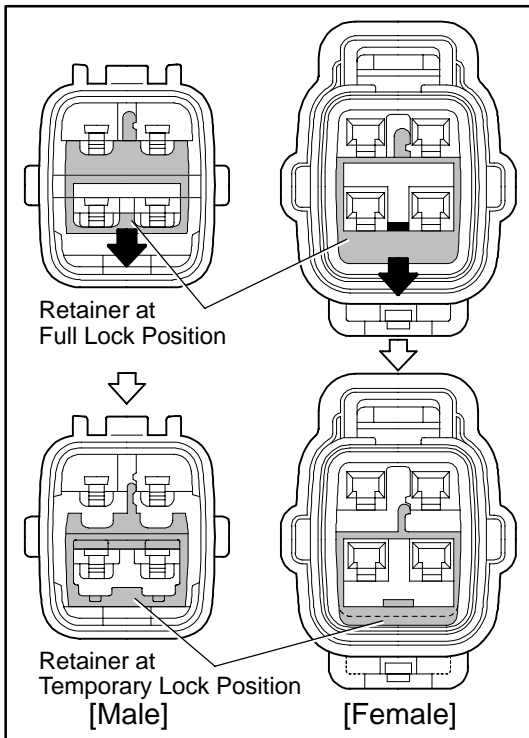

Push the terminal retainer down to the temporary lock position.

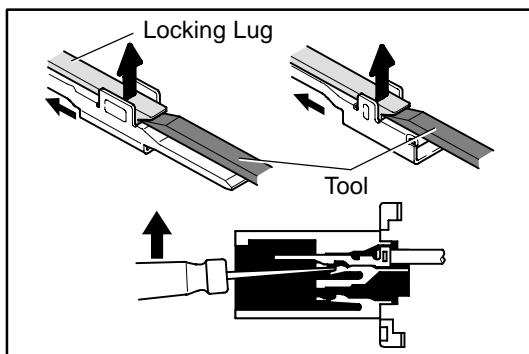

(c) Release the locking lug from terminal and pull the terminal out from rear.

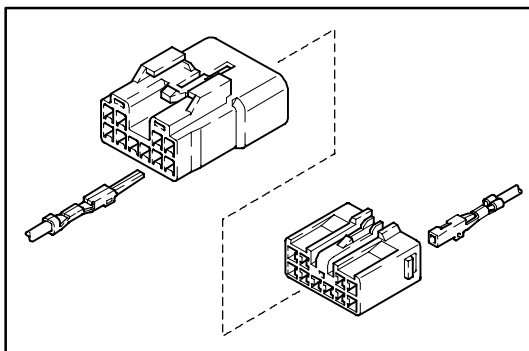

4. INSTALL TERMINAL TO CONNECTOR

(a) Insert the terminal.

HINT:

1. Make sure the terminal is positioned correctly.
2. Insert the terminal until the locking lug locks firmly.
3. Insert the terminal with terminal retainer in the temporary lock position.

(b) Push the secondary locking device or terminal retainer in to the full lock position.

5. CONNECT CONNECTOR

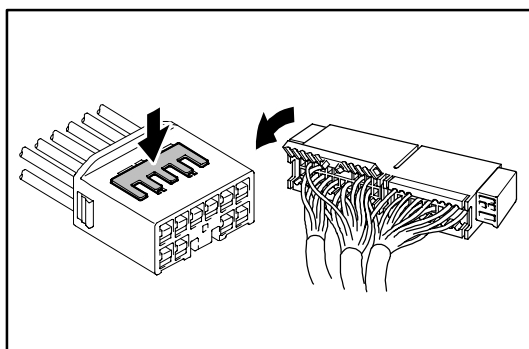











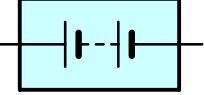
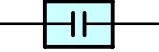
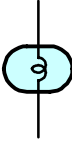

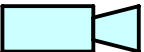

ABBREVIATIONS

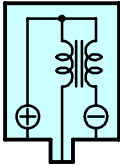



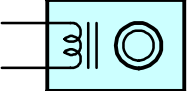

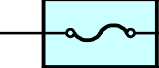
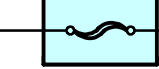
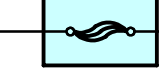
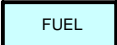

The following abbreviations are used in this manual.

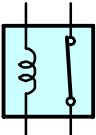
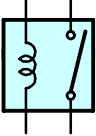
ABS	=	Anti-Lock Brake System
A/C	=	Air Conditioning
ACIS	=	Acoustic Control Induction System
A/T	=	Automatic Transmission
CD	=	Compact Disc
COMB.	=	Combination
D/A	=	Digital/Analog
ECU	=	Electronic Control Unit
ESA	=	Electronic Spark Advance
ETCS-i	=	Electronic Throttle Control System-intelligent
EVAP	=	Evaporative Emission
HID	=	High Intensity Discharge
IC	=	Integrated Circuit
J/B	=	Junction Block
LED	=	Light Emitting Diode
LH	=	Left-Hand
MPX	=	Multiplex
O/D	=	Overdrive
PPS	=	Progressive Power Steering
R/B	=	Relay Block
RH	=	Right-Hand
SFI	=	Sequential Multiport Fuel Injection
SRS	=	Supplemental Restraint System
SW	=	Switch
TEMP.	=	Temperature
TRAC	=	Traction Control
VSC	=	Vehicle Skid Control System
VSV	=	Vacuum Switching Valve
VVT	=	Variable Valve Timing
w/	=	With
w/o	=	Without

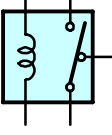
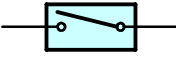
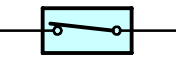
* The titles given inside the components are the names of the terminals (terminal codes) and are not treated as being abbreviations.

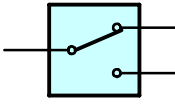
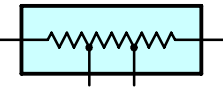
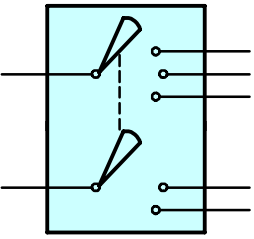
E GLOSSARY OF TERMS AND SYMBOLS

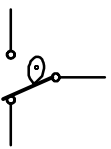
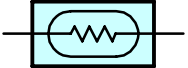
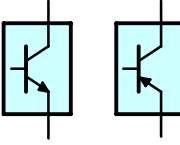
 <p>BATTERY Stores chemical energy and converts it into electrical energy. Provides DC current for the auto's various electrical circuits.</p>	 <p>GROUND The point at which wiring attaches to the Body, thereby providing a return path for an electrical circuit; without a ground, current cannot flow.</p>
 <p>CAPACITOR (Condenser) A small holding unit for temporary storage of electrical voltage.</p>	<p>HEADLIGHTS Current flow causes a headlight filament to heat up and emit light. A headlight may have either a single (1) filament or a double (2) filament</p> <p>1. SINGLE FILAMENT</p>  <p>2. DOUBLE FILAMENT</p> 
 <p>CIGARETTE LIGHTER An electric resistance heating element.</p>	
 <p>CIRCUIT BREAKER Basically a reusable fuse, a circuit breaker will heat and open if too much current flows through it. Some units automatically reset when cool, others must be manually reset.</p>	 <p>HORN An electric device which sounds a loud audible signal.</p>
 <p>DIODE A semiconductor which allows current flow in only one direction.</p>	 <p>IGNITION COIL Converts low-voltage DC current into high-voltage ignition current for firing the spark plugs.</p>
 <p>DIODE, ZENER A diode which allows current flow in one direction but blocks reverse flow only up to a specific voltage. Above that potential, it passes the excess voltage. This acts as a simple voltage regulator.</p>	 <p>LIGHT Current flow through a filament causes the filament to heat up and emit light.</p>
 <p>PHOTODIODE The photodiode is a semiconductor which controls the current flow according to the amount of light.</p>	 <p>LED (LIGHT EMITTING DIODE) Upon current flow, these diodes emit light without producing the heat of a comparable light.</p>
 <p>DISTRIBUTOR, IIA Channels high-voltage current from the ignition coil to the individual spark plugs.</p>	 <p>METER, ANALOG Current flow activates a magnetic coil which causes a needle to move, thereby providing a relative display against a background calibration.</p>
 <p>FUSE A thin metal strip which burns through when too much current flows through it, thereby stopping current flow and protecting a circuit from damage.</p>  <p>FUSIBLE LINK A heavy-gauge wire placed in high amperage circuits which burns through on overloads, thereby protecting the circuit. The numbers indicate the cross-section surface area of the wires.</p> <p>(for Medium Current Fuse)</p>  <p>(for High Current Fuse or Fusible Link)</p>	 <p>METER, DIGITAL Current flow activates one or many LED's, LCD's, or fluorescent displays, which provide a relative or digital display.</p>
	 <p>MOTOR A power unit which converts electrical energy into mechanical energy, especially rotary motion.</p>

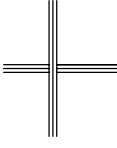
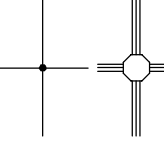
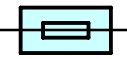
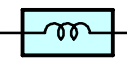
 <p>RELAY Basically, an electrically operated switch which may be normally closed (1) or open (2). Current flow through a small coil creates a magnetic field which either opens or closes an attached switch.</p> <p>1. NORMALLY CLOSED</p>  <p>2. NORMALLY OPEN</p>	 <p>SPEAKER An electromechanical device which creates sound waves from current flow.</p>
 <p>RELAY, DOUBLE THROW A relay which passes current through one set of contacts or the other.</p>	<p>SWITCH, MANUAL Opens and closes circuits, thereby stopping (1) or allowing (2) current flow.</p> <p>1. NORMALLY OPEN</p>  <p>2. NORMALLY CLOSED</p> 
 <p>RESISTOR An electrical component with a fixed resistance, placed in a circuit to reduce voltage to a specific value.</p>	<p>SWITCH, DOUBLE THROW A switch which continuously passes current through one set of contacts or the other.</p> 
 <p>RESISTOR, TAPPED A resistor which supplies two or more different non adjustable resistance values.</p>	<p>SWITCH, IGNITION A key operated switch with several positions which allows various circuits, particularly the primary ignition circuit, to become operational.</p> 
 <p>RESISTOR, VARIABLE or RHEOSTAT A controllable resistor with a variable rate of resistance. Also called a potentiometer or rheostat.</p>	<p>SWITCH, WIPER PARK Automatically returns wipers to the stop position when the wiper switch is turned off.</p> 
 <p>SENSOR (Thermistor) A resistor which varies its resistance with temperature.</p>	<p>TRANSISTOR A solidstate device typically used as an electronic relay; stops or passes current depending on the voltage applied at "base".</p> 
 <p>SENSOR, SPEED Uses magnetic impulses to open and close a switch to create a signal for activation of other components. (Reed Switch Type)</p>	<p>WIRES</p> <p>(1) NOT CONNECTED</p>  <p>(2) SPLICED</p>  <p>Wires are always drawn as straight lines on wiring diagrams. Crossed wires (1) without a black dot at the junction are not joined; crossed wires (2) with a black dot or octagonal mark at the junction are spliced (joined) connections.</p>
 <p>SHORT PIN Used to provide an unbroken connection within a junction block.</p>	
 <p>SOLENOID An electromagnetic coil which forms a magnetic field when current flows, to move a plunger, etc.</p>	

F RELAY LOCATIONS

[Engine Compartment]

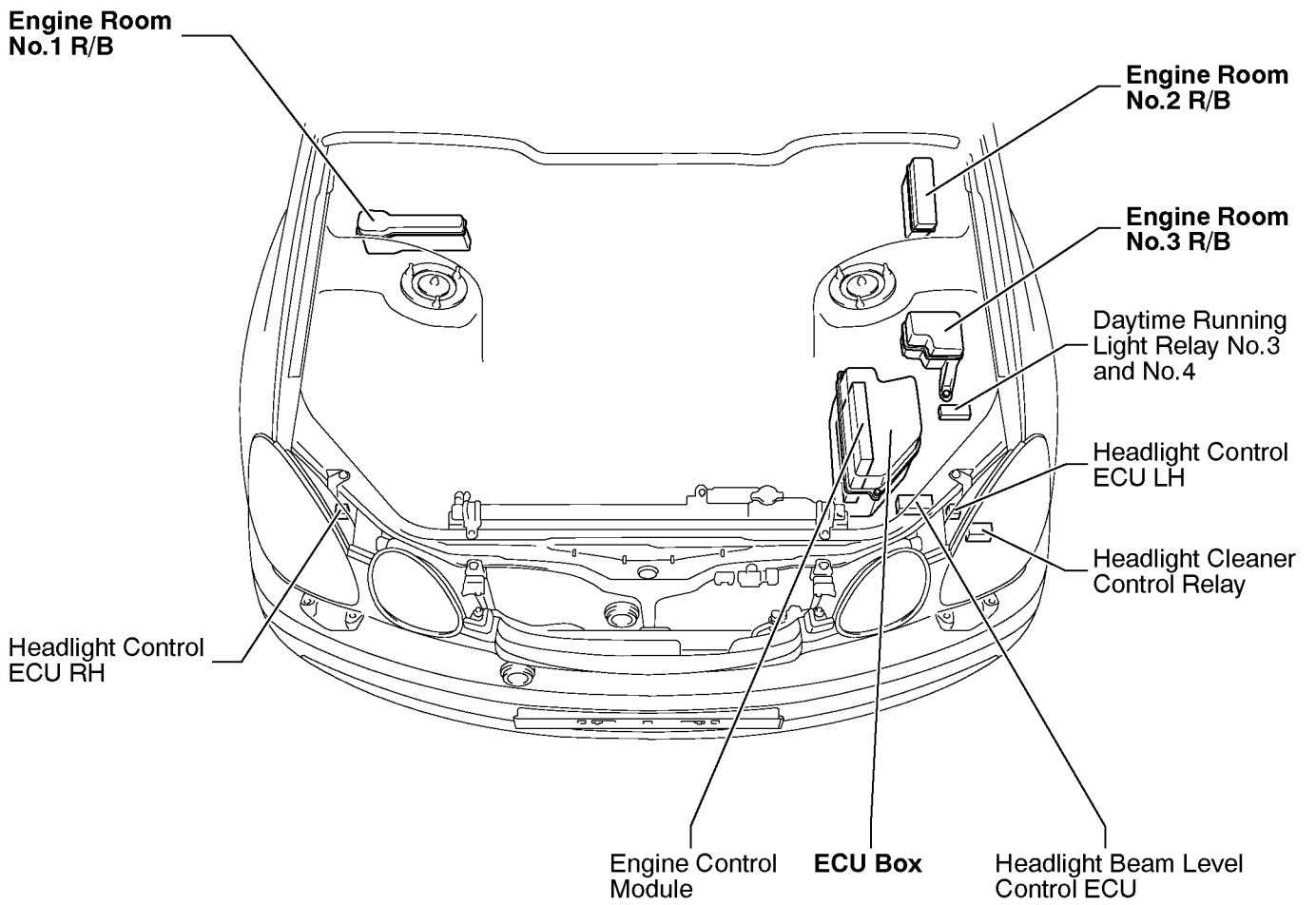

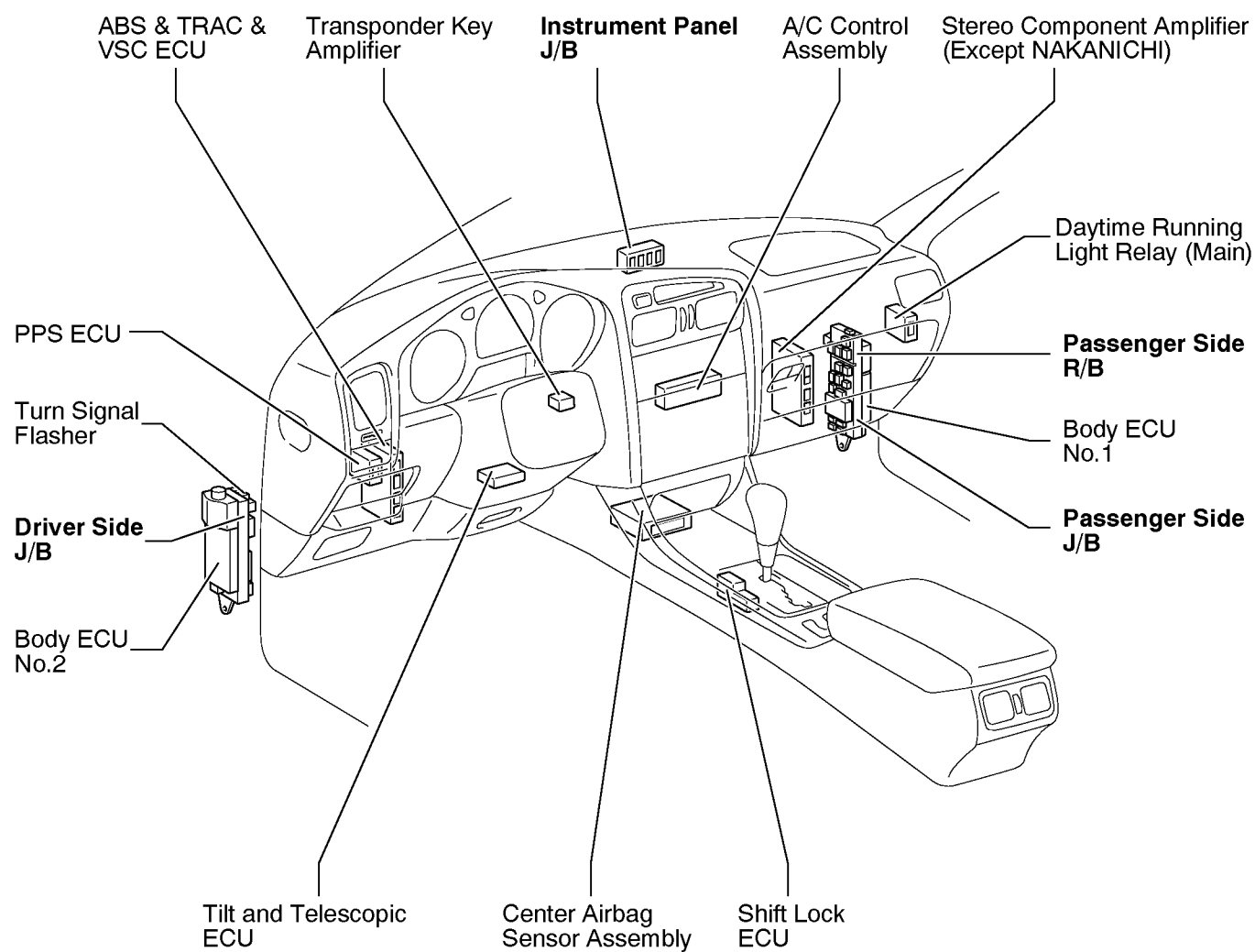
[Instrument Panel]

F RELAY LOCATIONS

[Body]

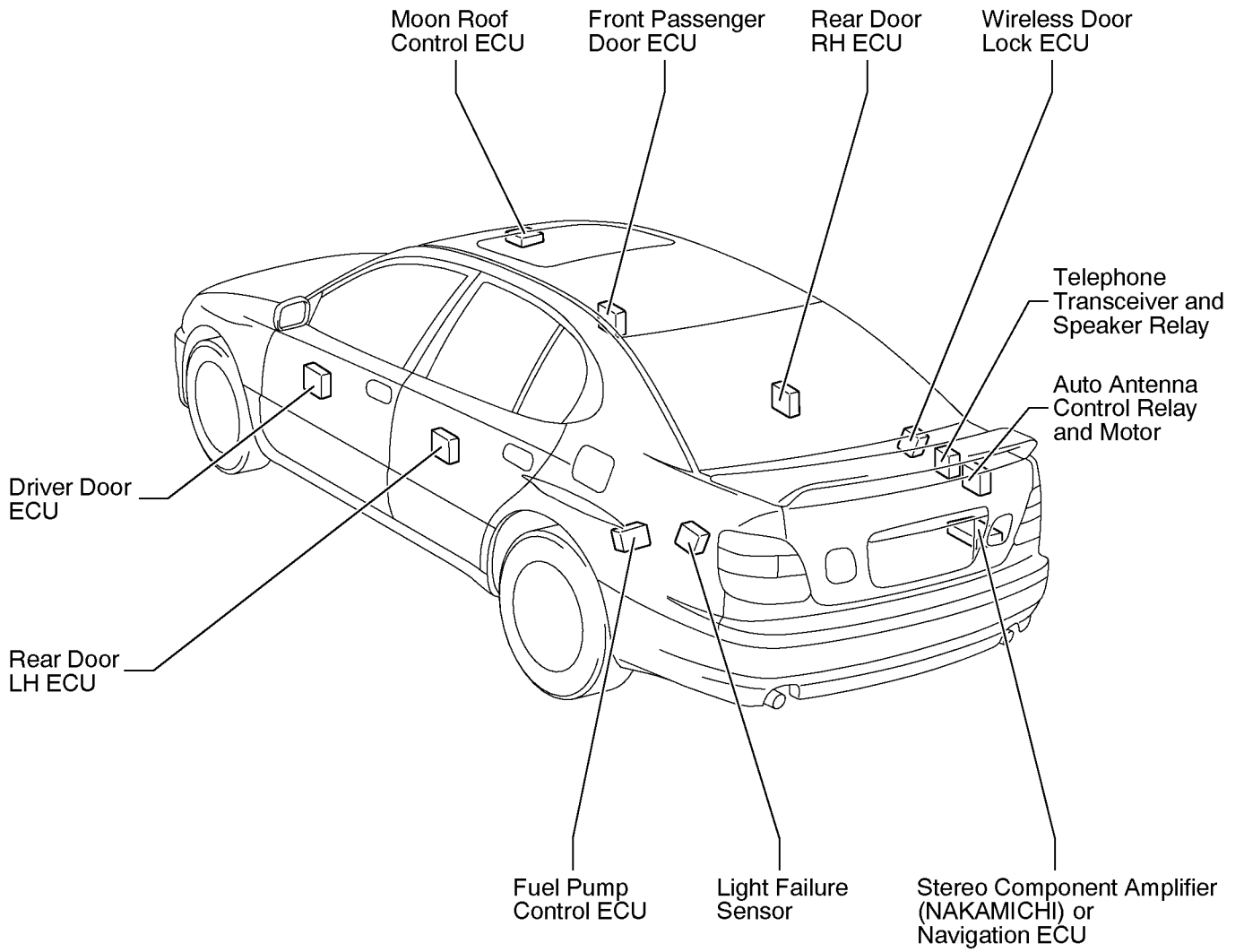

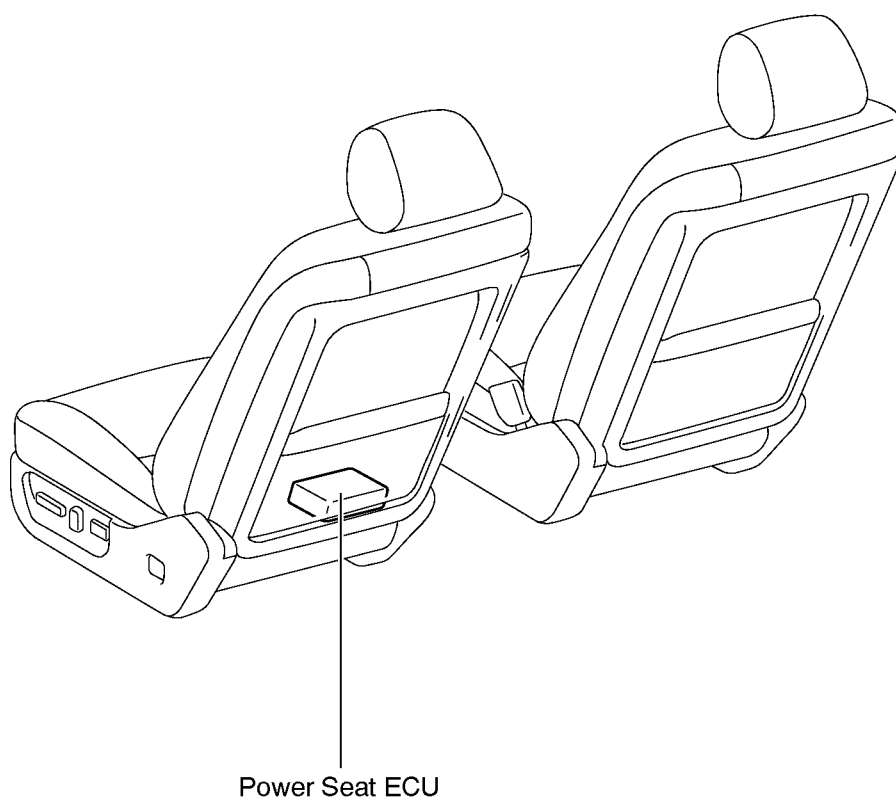
[Seat]

F RELAY LOCATIONS

① : Engine Room No.1 R/B Engine Compartment Right (See Page 18)

- *1 : w/o Daytime Running Light
- *2 : w/ Daytime Running Light
- *3 : 10A H-LP R UPR (*1),
30A DRL NO.1 (*2)

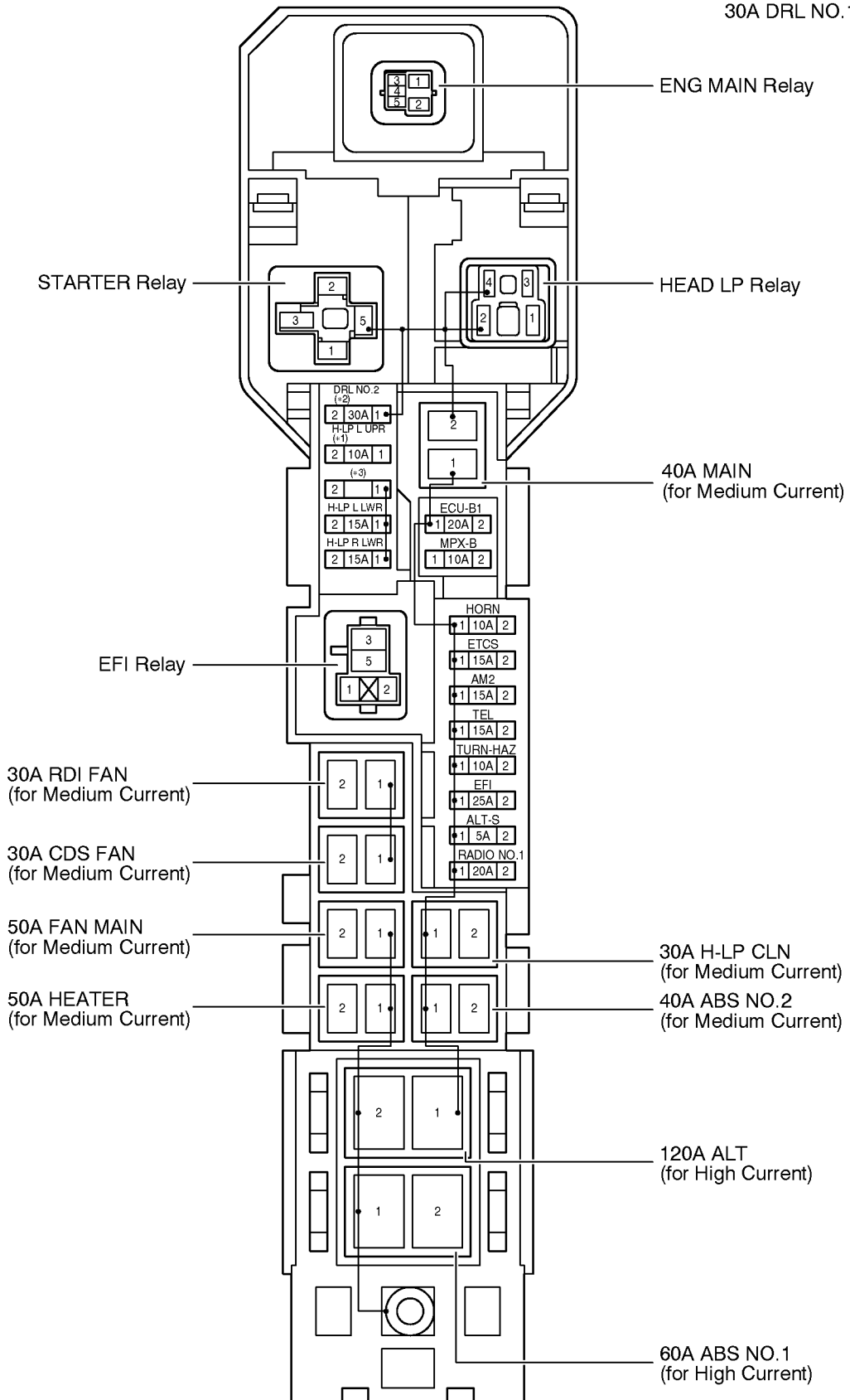

② : Engine Room No.2 R/B Engine Compartment Left (See Page 18)

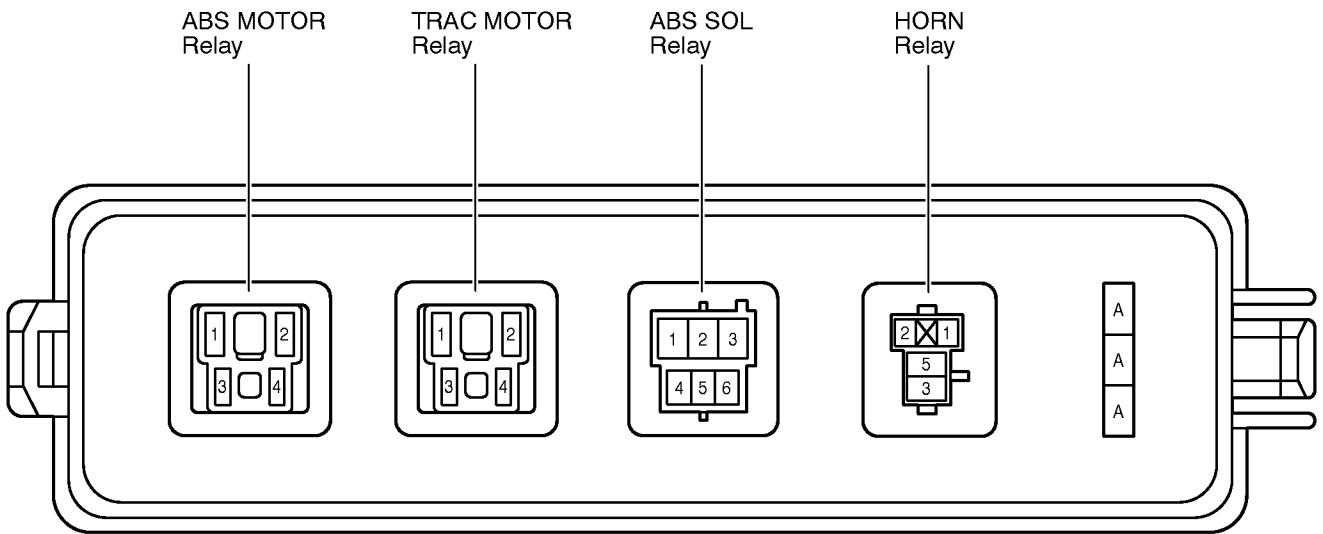

F RELAY LOCATIONS

③ : Engine Room No.3 R/B Engine Compartment Left (See Page 18)

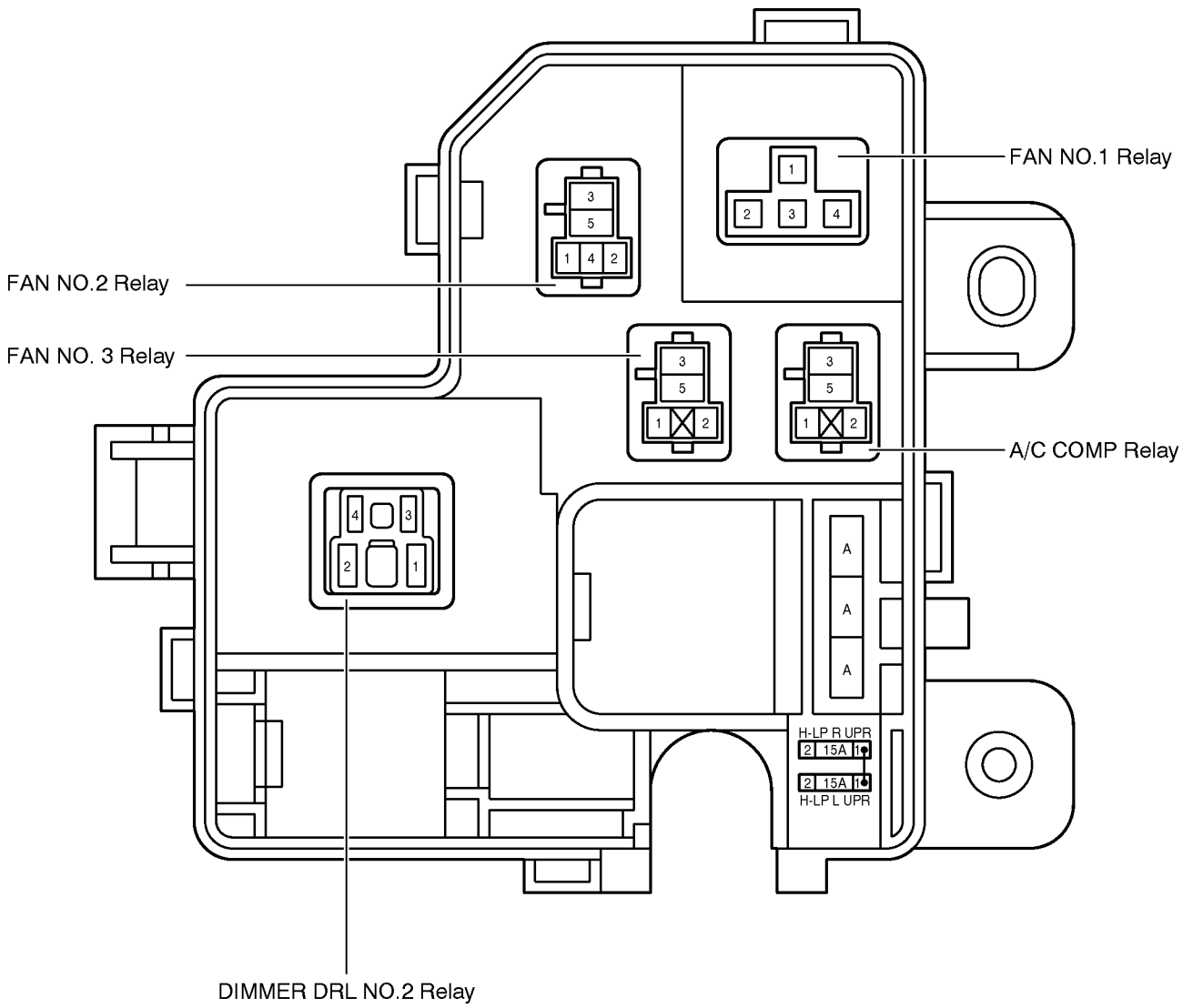

④ : Passenger Side R/B

Right Kick Panel (See Page 19)

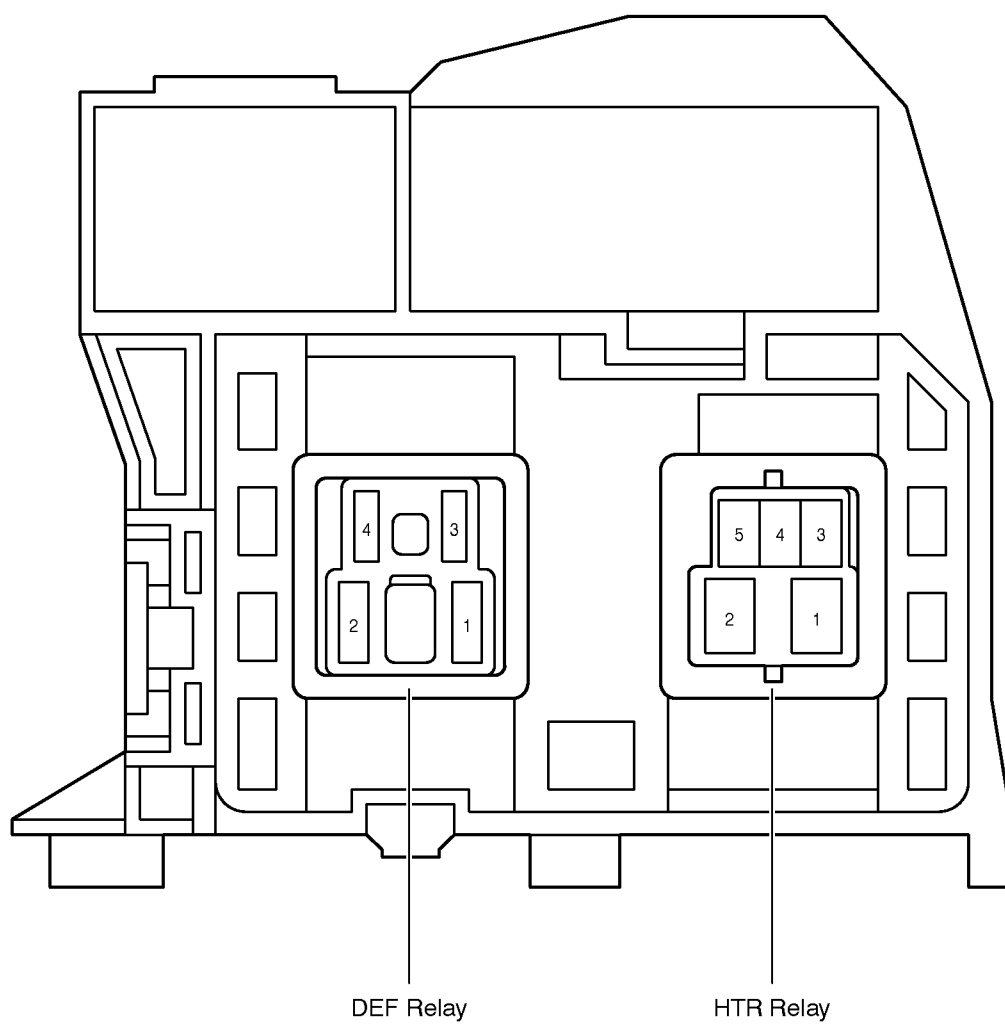

F RELAY LOCATIONS

○ : Driver Side J/B Left Kick Panel (See Page 19)

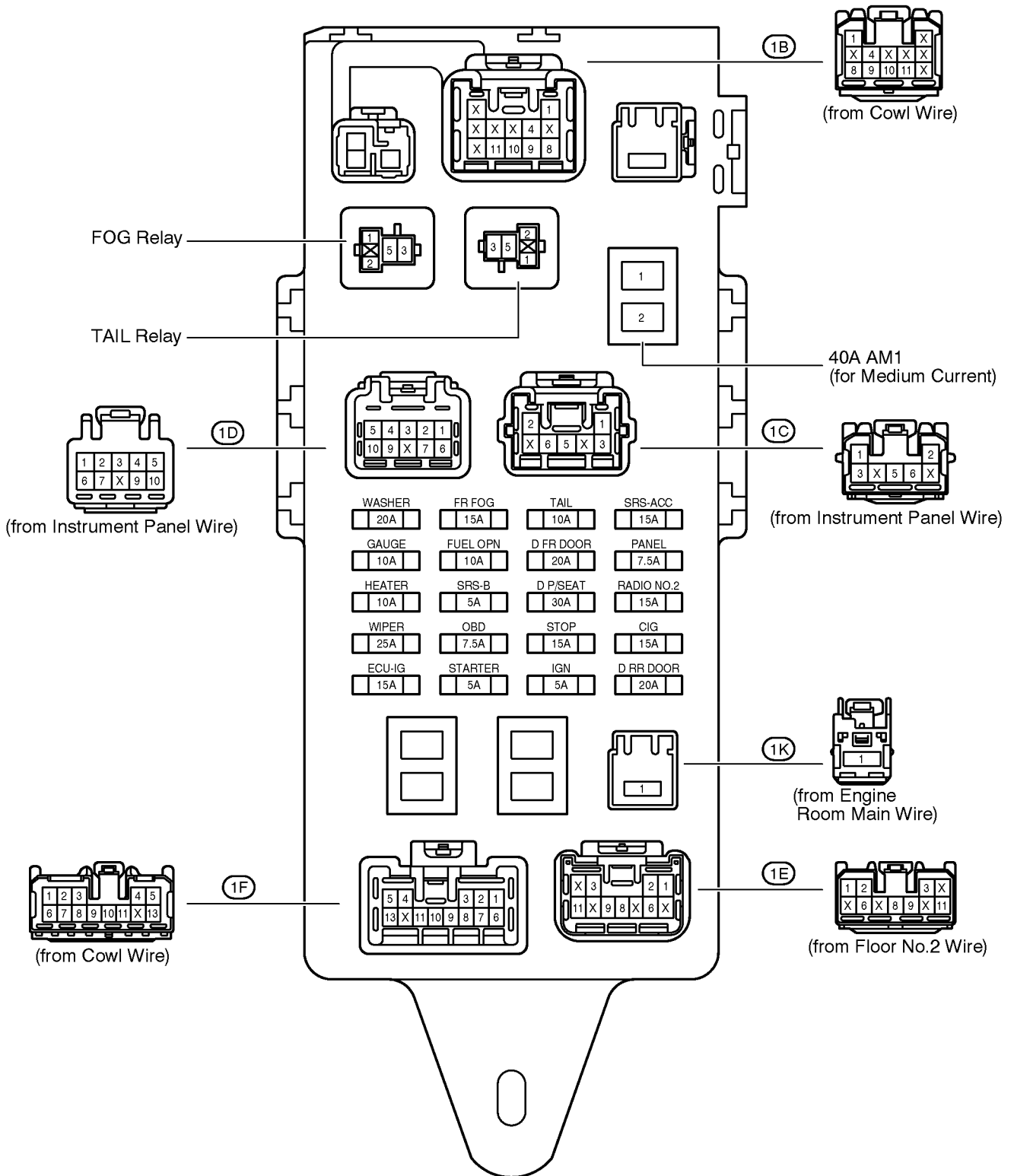

(Inner Circuit : See Page 32)

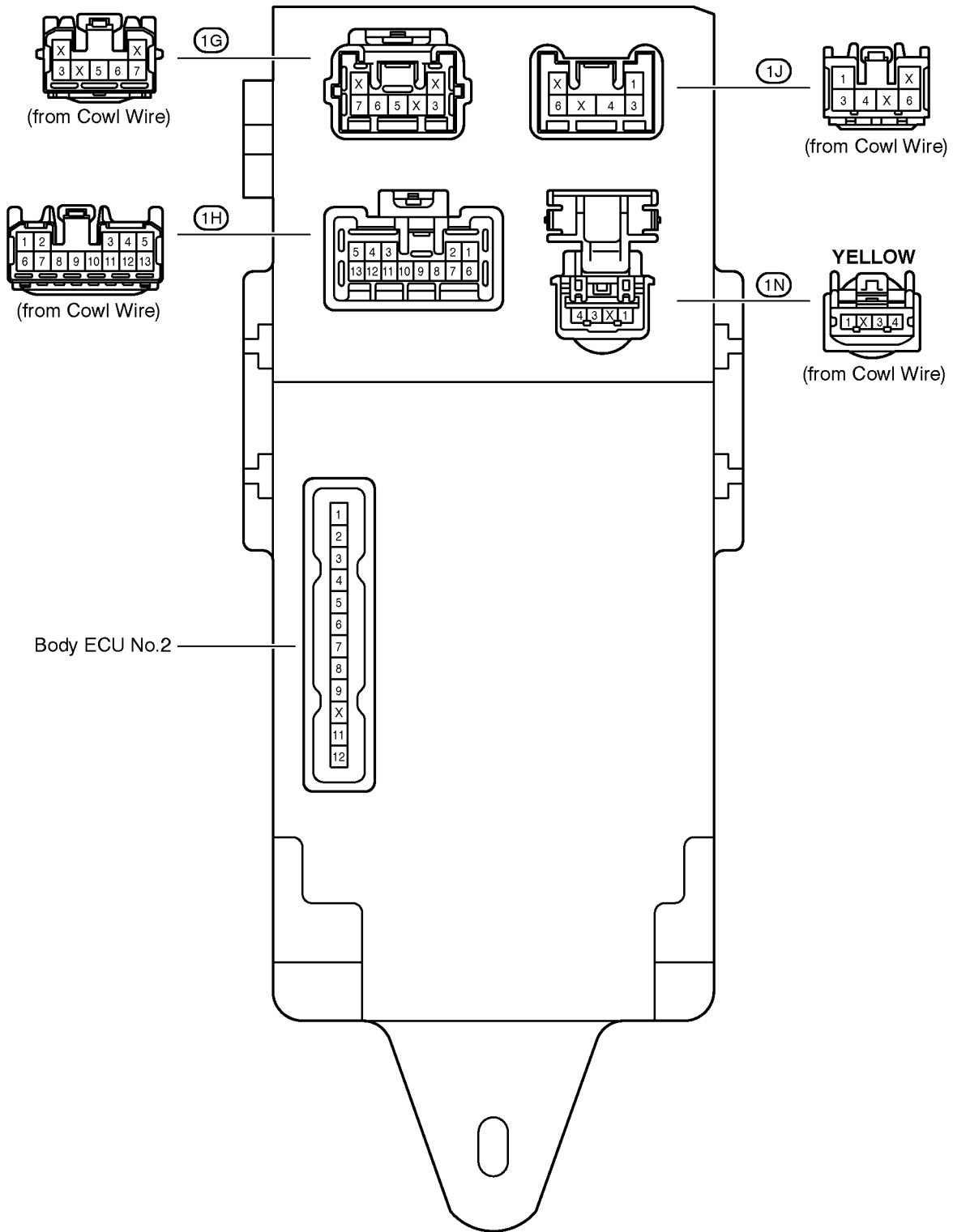

F RELAY LOCATIONS

○ : Passenger Side J/B Right Kick Panel (See Page 19)

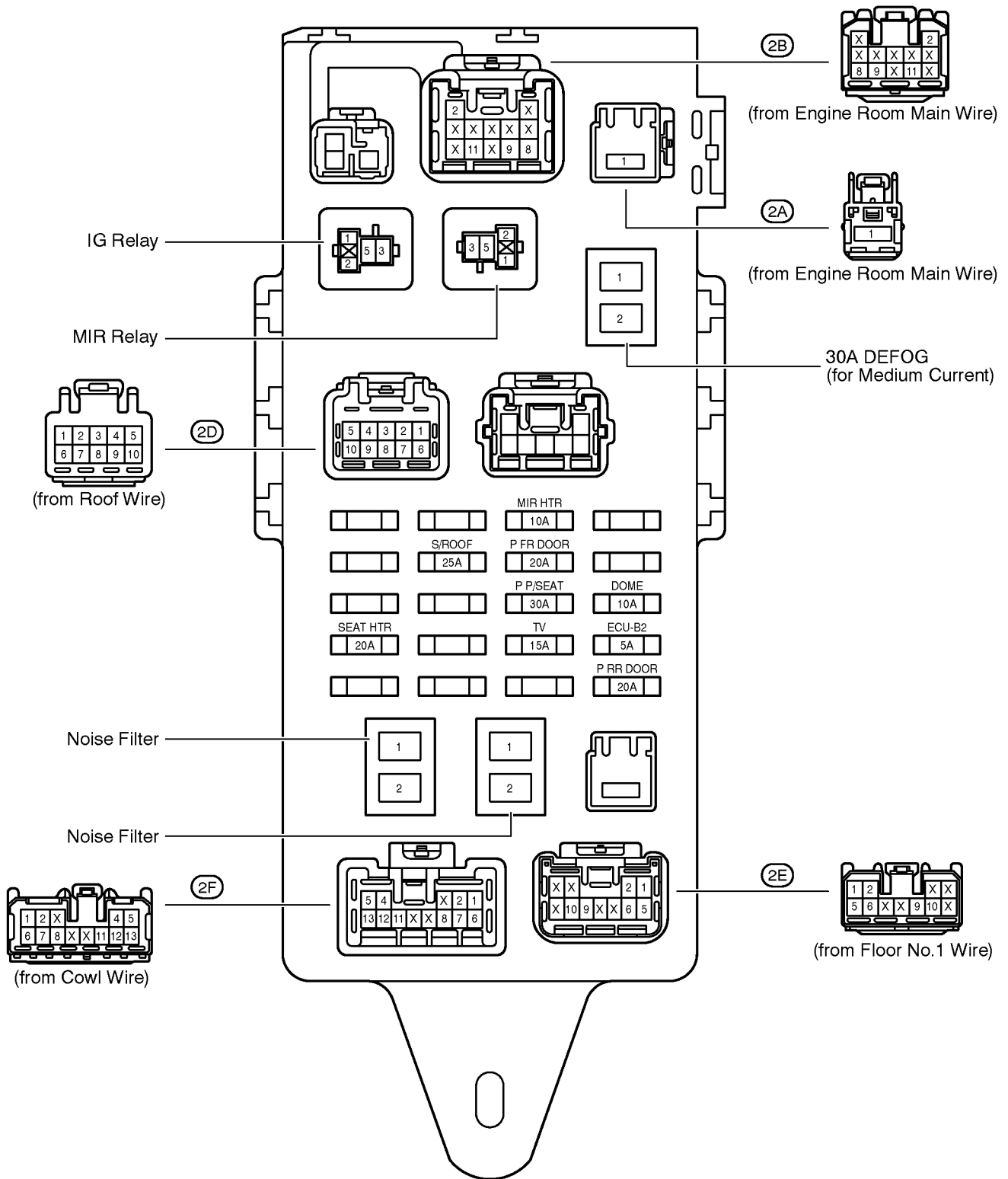

(Inner Circuit : See Page 33)

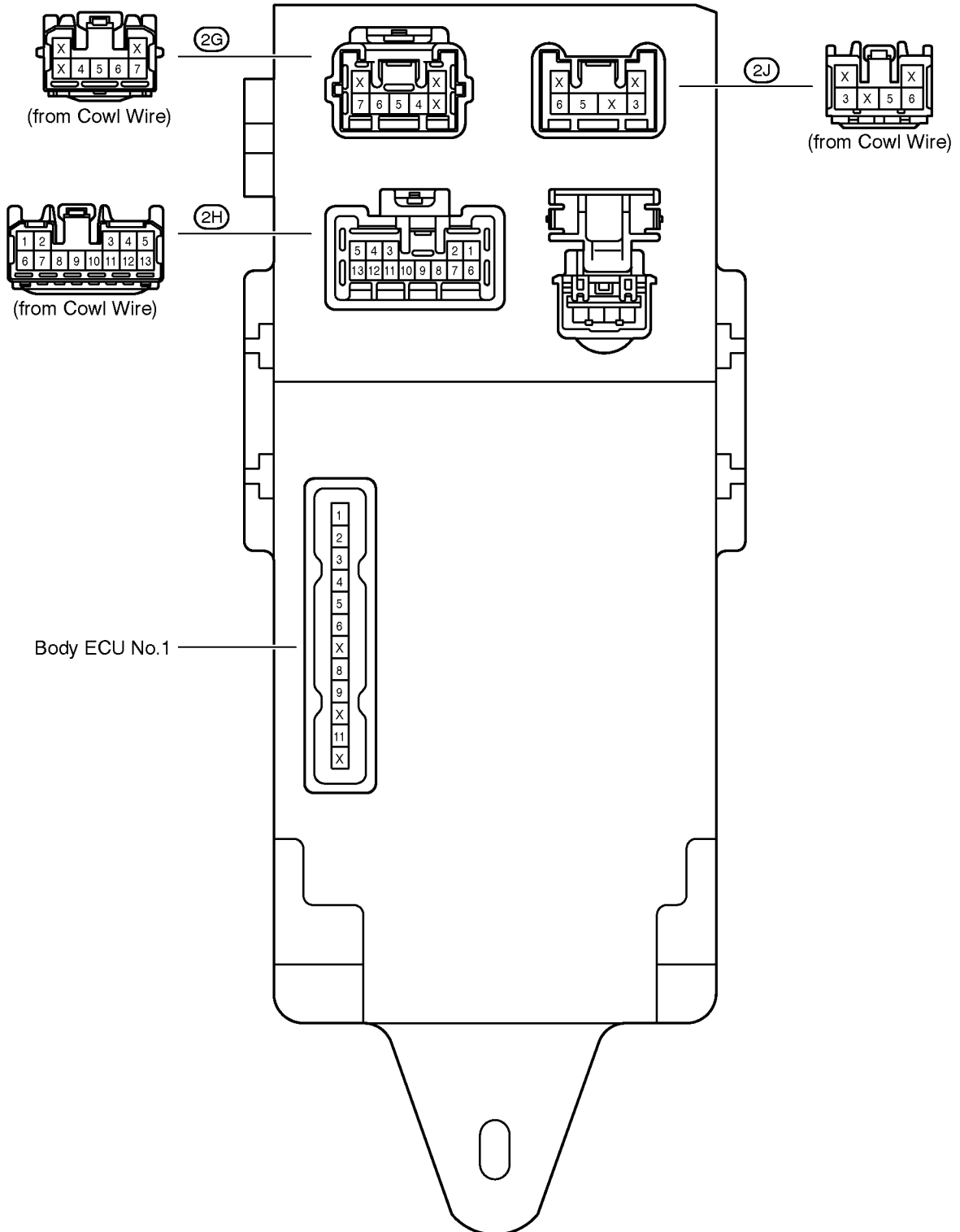

F RELAY LOCATIONS

○ : Instrument Panel J/B
 Instrument Panel Reinforcement Center
(See Page 19)

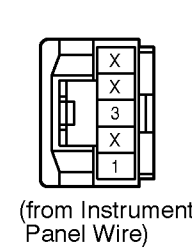
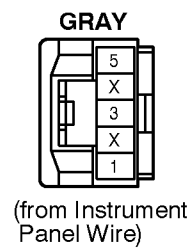
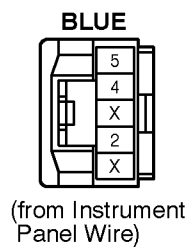
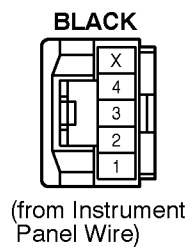
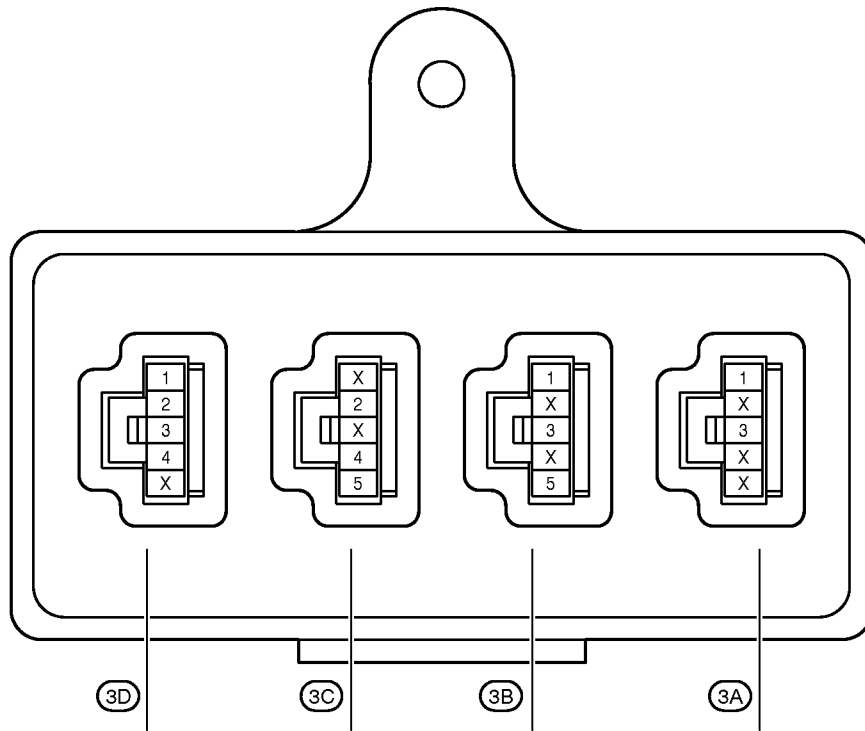

(Inner Circuit : See Page 34)

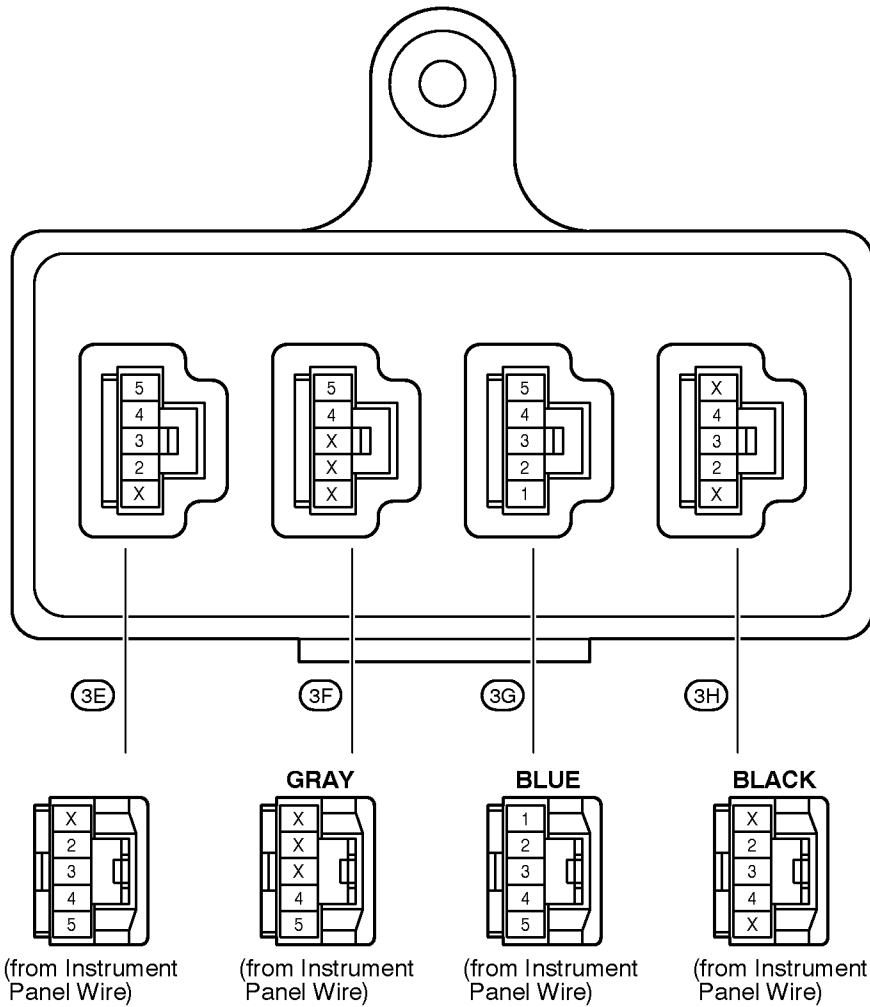

F RELAY LOCATIONS

[Driver Side J/B Inner Circuit]

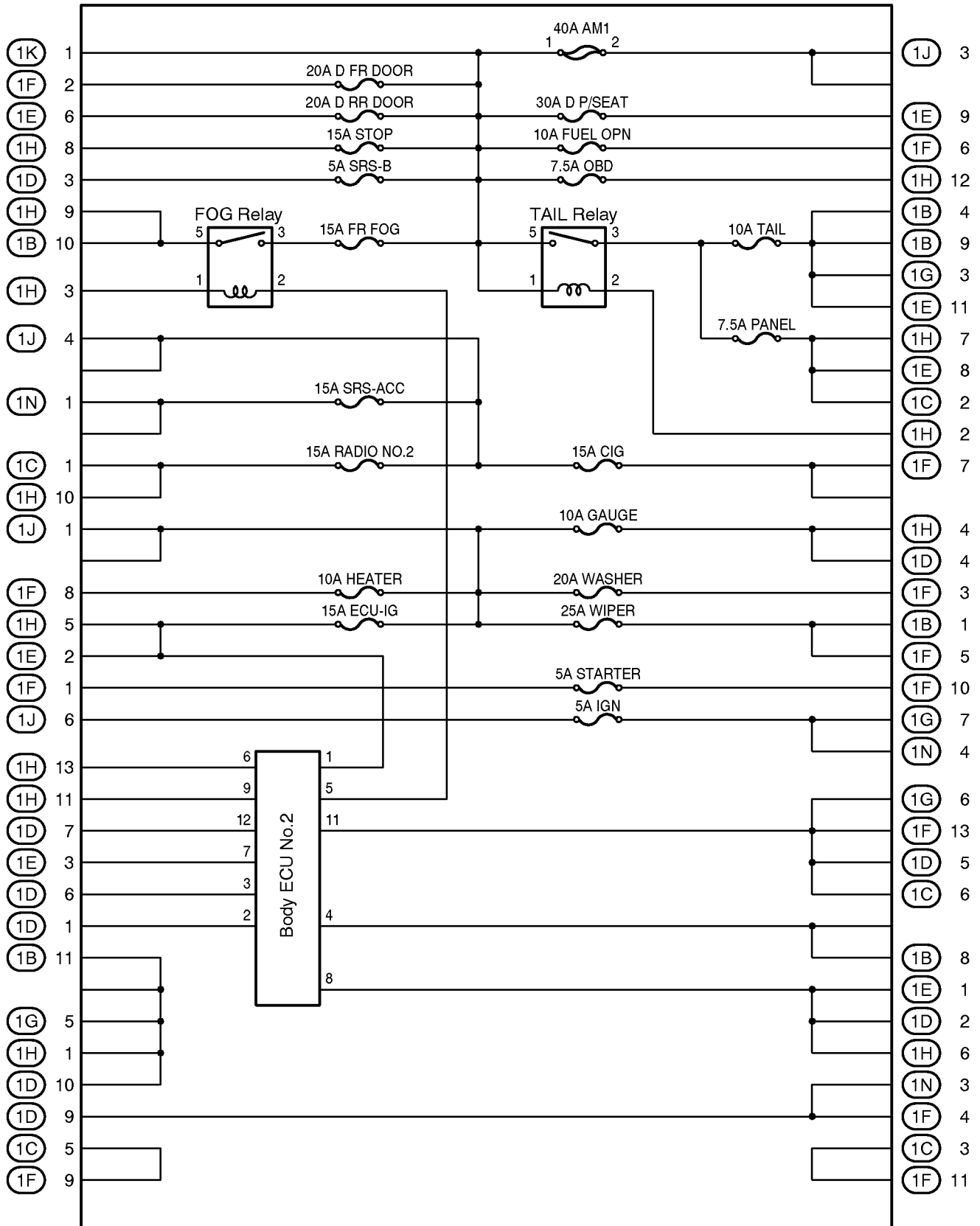

[Passenger Side J/B Inner Circuit]

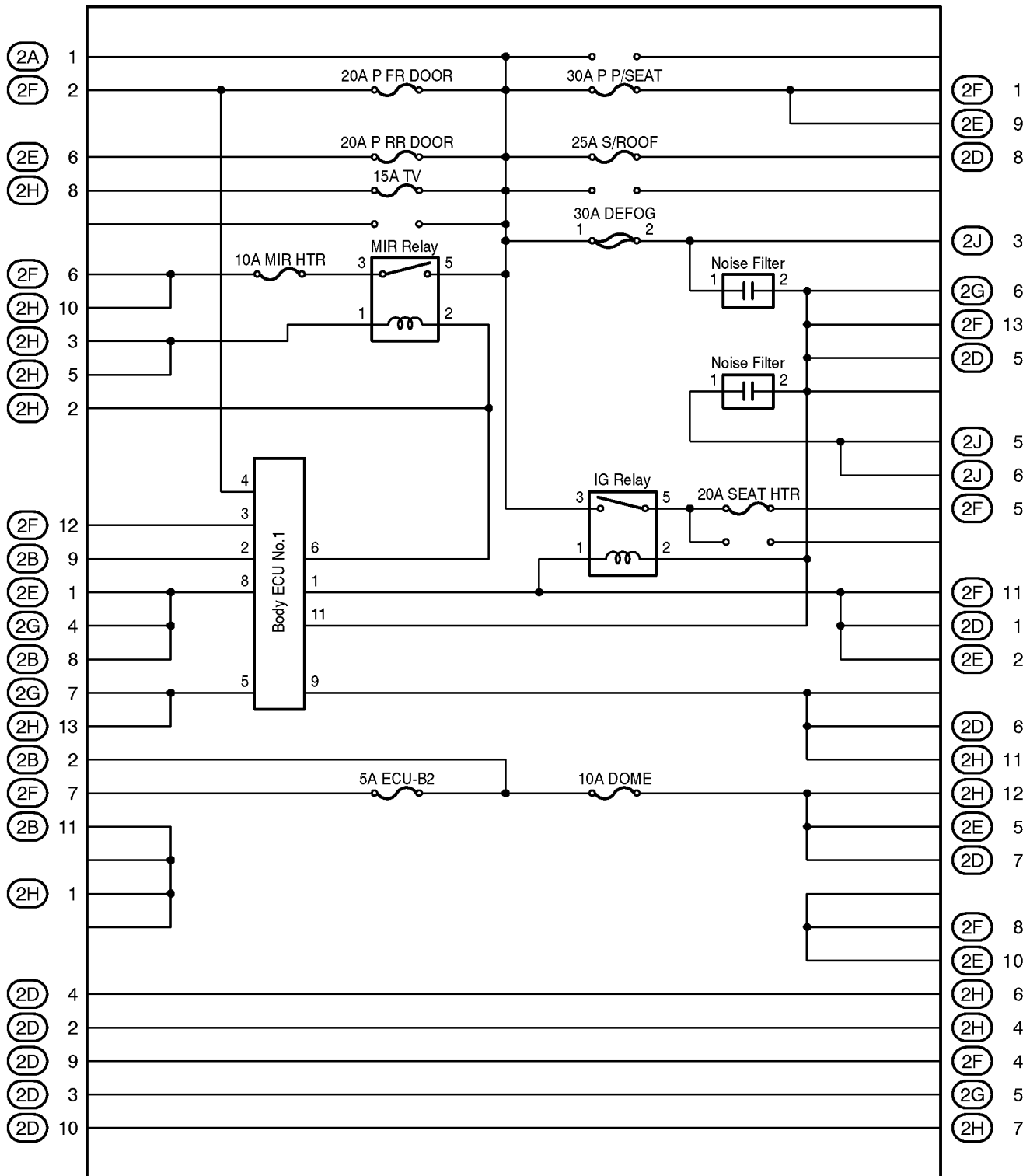

F RELAY LOCATIONS

[Instrument Panel J/B Inner Circuit]

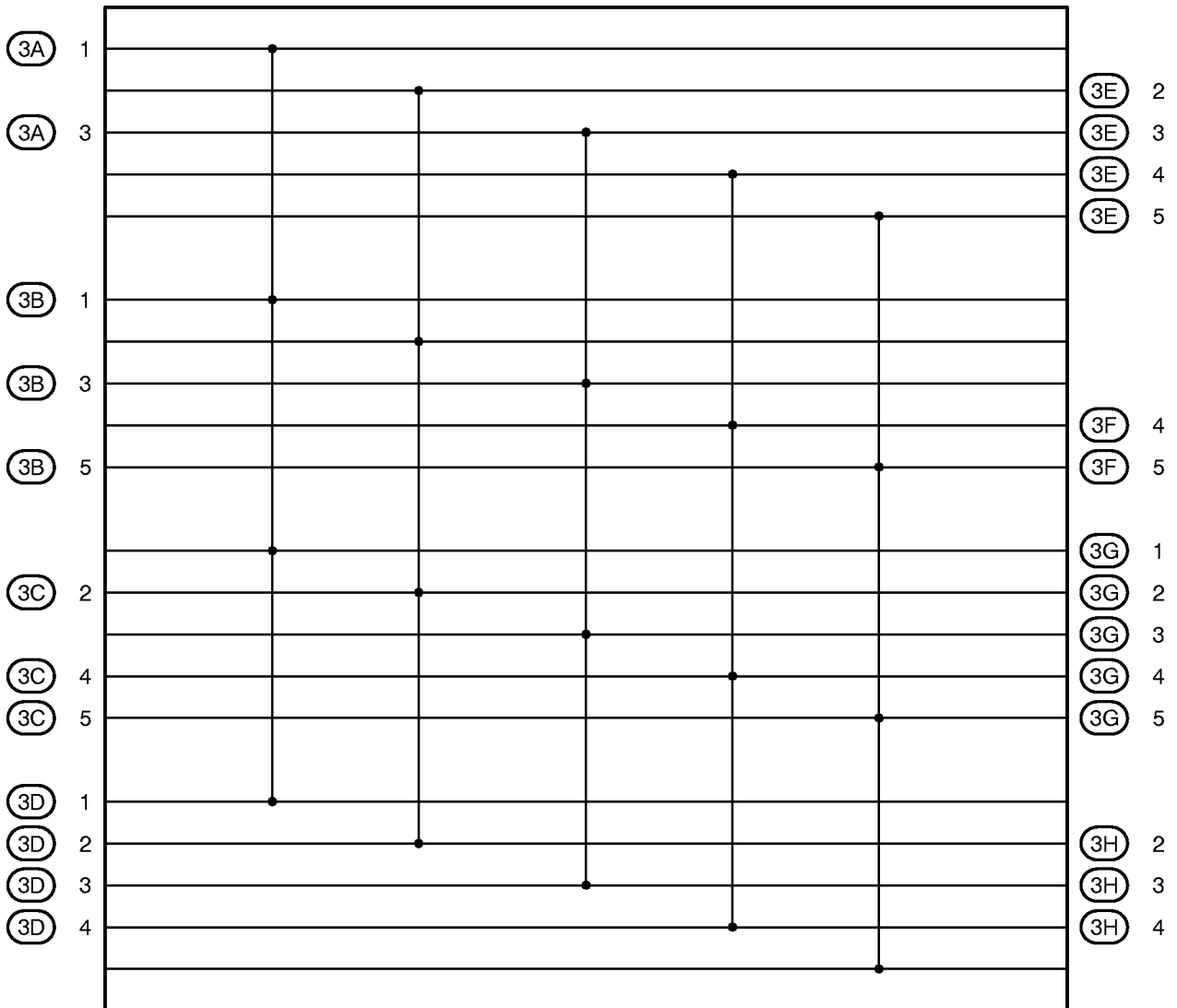

G ELECTRICAL WIRING ROUTING

Position of Parts in Engine Compartment

[1UZ-FE]

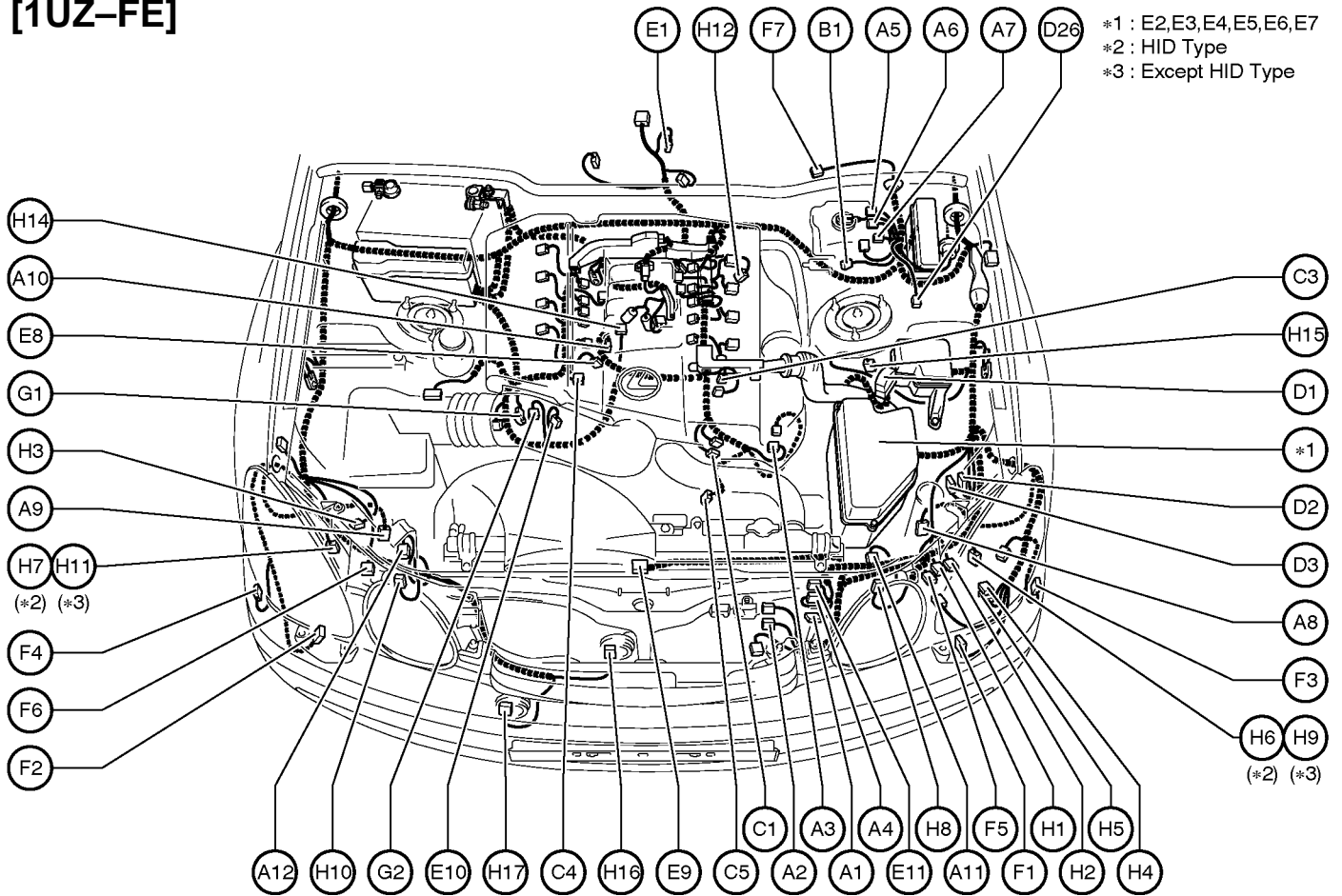

- A 1 A/C Ambient Temp. Sensor
- A 2 A/C Condenser Fan Motor
- A 3 A/C Magnetic Clutch and Lock Sensor
- A 4 A/C Triple Pressure SW (A/C Dual and Single Pressure SW)
- A 5 ABS & TRAC & VSC Actuator
- A 6 ABS & TRAC & VSC Actuator
- A 7 ABS & TRAC & VSC Actuator
- A 8 ABS Speed Sensor Front LH
- A 9 ABS Speed Sensor Front RH
- A10 Accelerator Pedal Position Sensor
- A11 Airbag Sensor Front LH
- A12 Airbag Sensor Front RH

- B 1 Brake Fluid Level Warning SW

- C 1 Camshaft Position Sensor
- C 3 Camshaft Timing Oil Control Valve LH
- C 4 Camshaft Timing Oil Control Valve RH
- C 5 Crankshaft Position Sensor

- D 1 Data Link Connector 1
- D 2 Daytime Running Light Relay No.3
- D 3 Daytime Running Light Relay No.4
- D26 Daytime Running Light Resistor or Short Connector

- E 1 Electronically Controlled Transmission Solenoid
- E 2 Engine Control Module
- E 3 Engine Control Module
- E 4 Engine Control Module
- E 5 Engine Control Module
- E 6 Engine Control Module
- E 7 Engine Control Module
- E 8 Engine Coolant Temp. Sensor

- E 9 Engine Hood Courtesy SW
- E10 Engine Oil Level Sensor
- E11 Exhaust Gas Sensor

- F 1 Front Fog Light LH
- F 2 Front Fog Light RH
- F 3 Front Side Marker Light LH
- F 4 Front Side Marker Light RH
- F 5 Front Turn Signal and Parking Light LH
- F 6 Front Turn Signal and Parking Light RH
- F 7 Front Wiper Motor

- G 1 Generator
- G 2 Generator

- H 1 Headlight Beam Level Control ECU
- H 2 Headlight Beam Level Control ECU
- H 3 Headlight Beam Level Control Motor
- H 4 Headlight Cleaner Control Relay
- H 5 Headlight Cleaner Motor
- H 6 Headlight Control ECU LH
- H 7 Headlight Control ECU RH
- H 8 Headlight LH (High)
- H 9 Headlight LH (Low)
- H10 Headlight RH (High)
- H11 Headlight RH (Low)
- H12 Heated Oxygen Sensor (Bank 1 Sensor 1)
- H14 Heated Oxygen Sensor (Bank 2 Sensor 1)
- H15 Height Control Sensor (Front)
- H16 Horn LH
- H17 Horn RH

Position of Parts in Engine Compartment

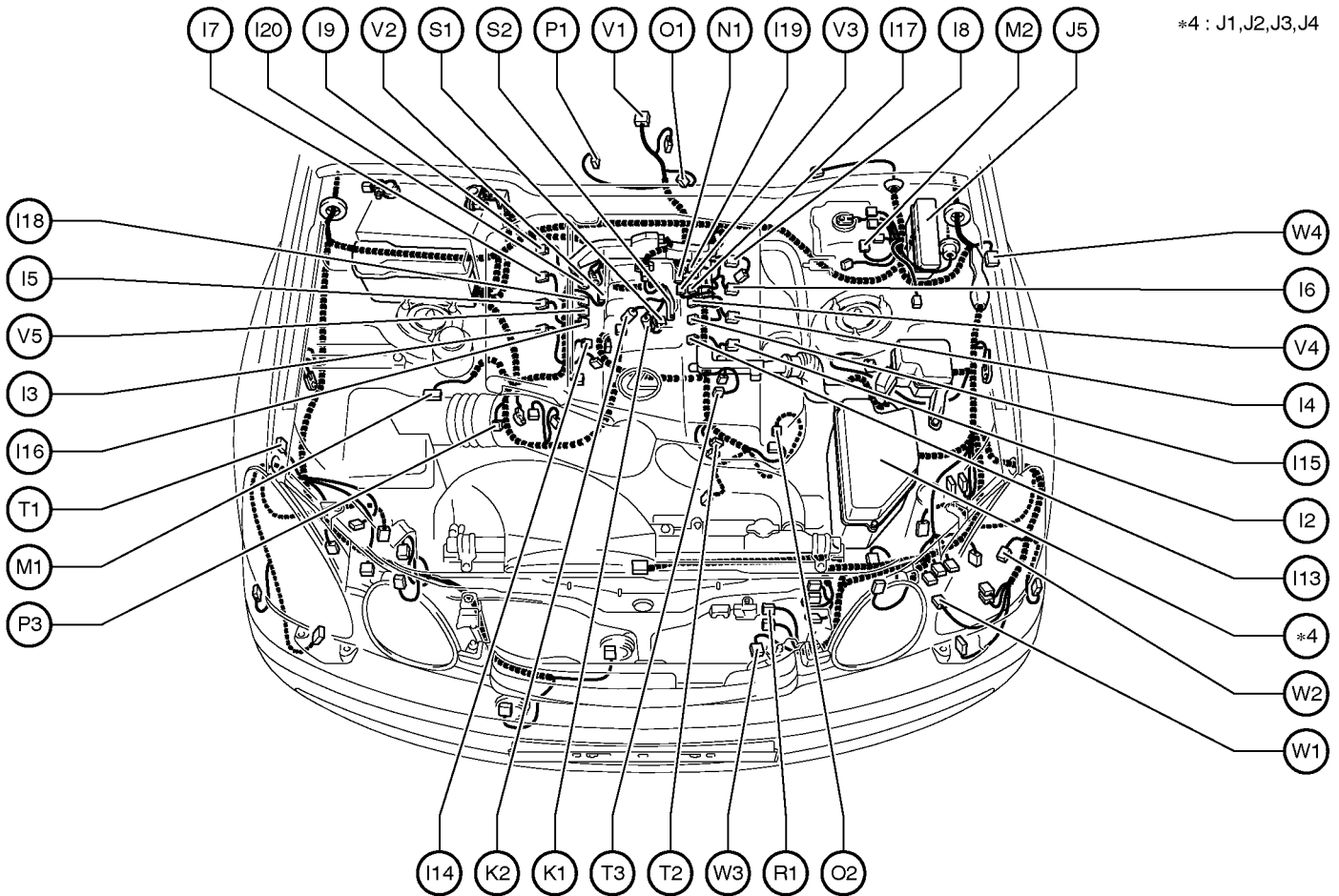

I 2 Ignition Coil and Igniter No.1
 I 3 Ignition Coil and Igniter No.2
 I 4 Ignition Coil and Igniter No.3
 I 5 Ignition Coil and Igniter No.4
 I 6 Ignition Coil and Igniter No.5
 I 7 Ignition Coil and Igniter No.6
 I 8 Ignition Coil and Igniter No.7
 I 9 Ignition Coil and Igniter No.8
 I 13 Injector No.1
 I 14 Injector No.2
 I 15 Injector No.3
 I 16 Injector No.4
 I 17 Injector No.5
 I 18 Injector No.6
 I 19 Injector No.7
 I 20 Injector No.8

J 1 Junction Connector
 J 2 Junction Connector
 J 3 Junction Connector
 J 4 Junction Connector
 J 5 Junction Connector

K 1 Knock Sensor 1
 K 2 Knock Sensor 2

M 1 Mass Air Flow Meter
 M 2 Master Cylinder Pressure Sensor

N 1 Noise Filter (Ignition)

O 1 O/D Direct Clutch Speed Sensor
 O 2 Oil Pressure SW

P 1 Park/Neutral Position SW
 P 3 PPS Solenoid

R 1 Radiator Fan Motor

S 1 Starter
 S 2 Starter

T 1 Theft Deterrent Horn
 T 2 Throttle Control Motor
 T 3 Throttle Position Sensor

V 1 Vehicle Speed Sensor (Electronically Controlled Transmission)
 V 2 VSV (ACIS)
 V 3 VSV (EVAP)
 V 4 VVT Sensor LH
 V 5 VVT Sensor RH

W 1 Washer Level Warning SW
 W 2 Washer Motor
 W 3 Water Temp. SW
 W 4 Wireless Door Lock Buzzer

G ELECTRICAL WIRING ROUTING

Position of Parts in Engine Compartment

[2JZ-GE]

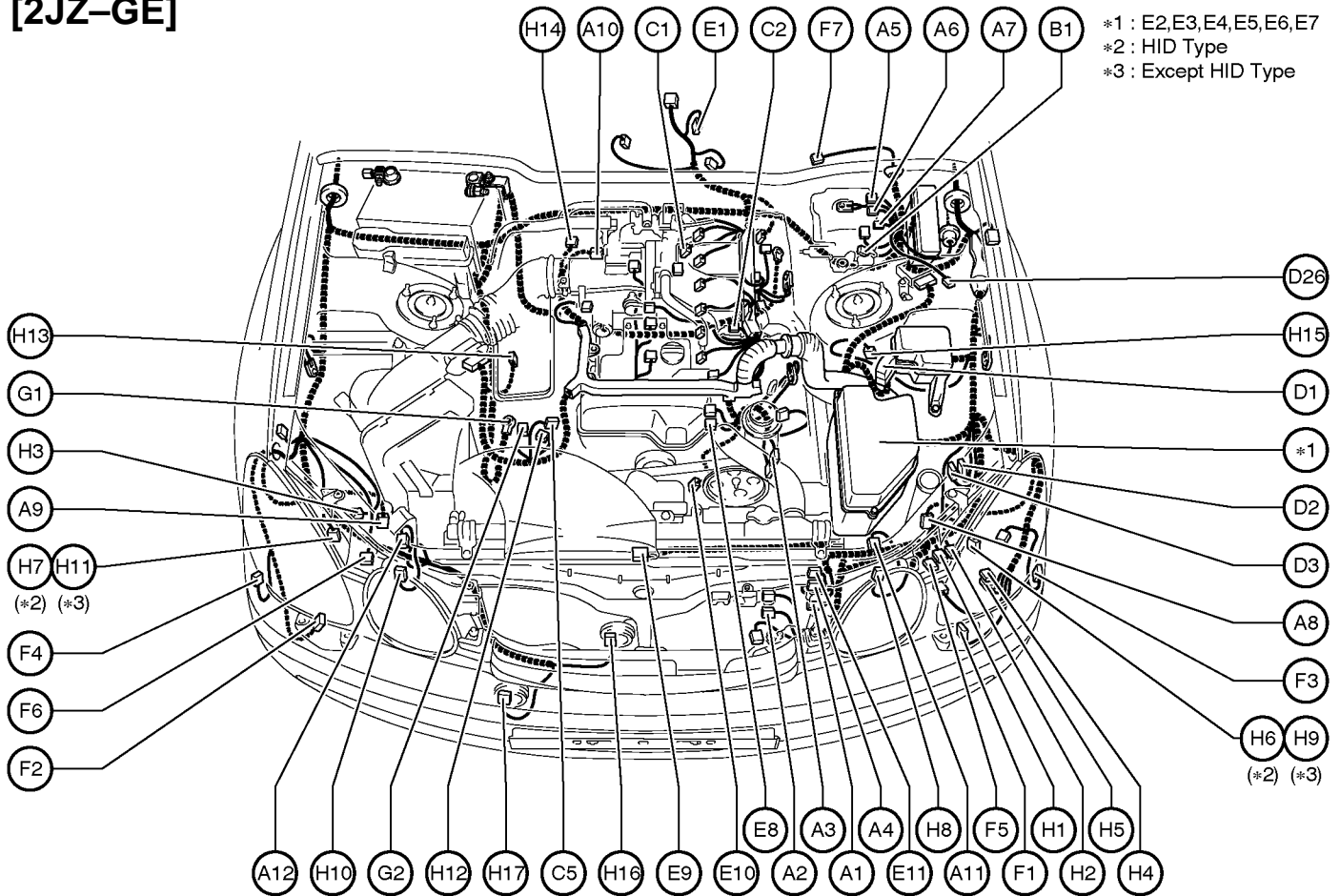

- A 1 A/C Ambient Temp. Sensor
- A 2 A/C Condenser Fan Motor
- A 3 A/C Magnetic Clutch and Lock Sensor
- A 4 A/C Triple Pressure SW (A/C Dual and Single Pressure SW)
- A 5 ABS & TRAC & VSC Actuator
- A 6 ABS & TRAC & VSC Actuator
- A 7 ABS & TRAC & VSC Actuator
- A 8 ABS Speed Sensor Front LH
- A 9 ABS Speed Sensor Front RH
- A10 Accelerator Pedal Position Sensor
- A11 Airbag Sensor Front LH
- A12 Airbag Sensor Front RH

- B 1 Brake Fluid Level Warning SW

- C 1 Camshaft Position Sensor
- C 2 Camshaft Timing Oil Control Valve
- C 5 Crankshaft Position Sensor

- D 1 Data Link Connector 1
- D 2 Daytime Running Light Relay No.3
- D 3 Daytime Running Light Relay No.4
- D26 Daytime Running Light Resistor or Short Connector

- E 1 Electronically Controlled Transmission Solenoid
- E 2 Engine Control Module
- E 3 Engine Control Module
- E 4 Engine Control Module
- E 5 Engine Control Module
- E 6 Engine Control Module
- E 7 Engine Control Module
- E 8 Engine Coolant Temp. Sensor

- E 9 Engine Hood Courtesy SW
- E10 Engine Oil Level Sensor
- E11 Exhaust Gas Sensor

- F 1 Front Fog Light LH
- F 2 Front Fog Light RH
- F 3 Front Side Marker Light LH
- F 4 Front Side Marker Light RH
- F 5 Front Turn Signal and Parking Light LH
- F 6 Front Turn Signal and Parking Light RH
- F 7 Front Wiper Motor

- G 1 Generator
- G 2 Generator

- H 1 Headlight Beam Level Control ECU
- H 2 Headlight Beam Level Control ECU
- H 3 Headlight Beam Level Control Motor
- H 4 Headlight Cleaner Control Relay
- H 5 Headlight Cleaner Motor
- H 6 Headlight Control ECU LH
- H 7 Headlight Control ECU RH
- H 8 Headlight LH (High)
- H 9 Headlight LH (Low)
- H10 Headlight RH (High)
- H11 Headlight RH (Low)
- H12 Heated Oxygen Sensor (Bank 1 Sensor 1)
- H13 Heated Oxygen Sensor (Bank 1 Sensor 2)
- H14 Heated Oxygen Sensor (Bank 2 Sensor 1)
- H15 Height Control Sensor (Front)
- H16 Horn LH
- H17 Horn RH

Position of Parts in Engine Compartment

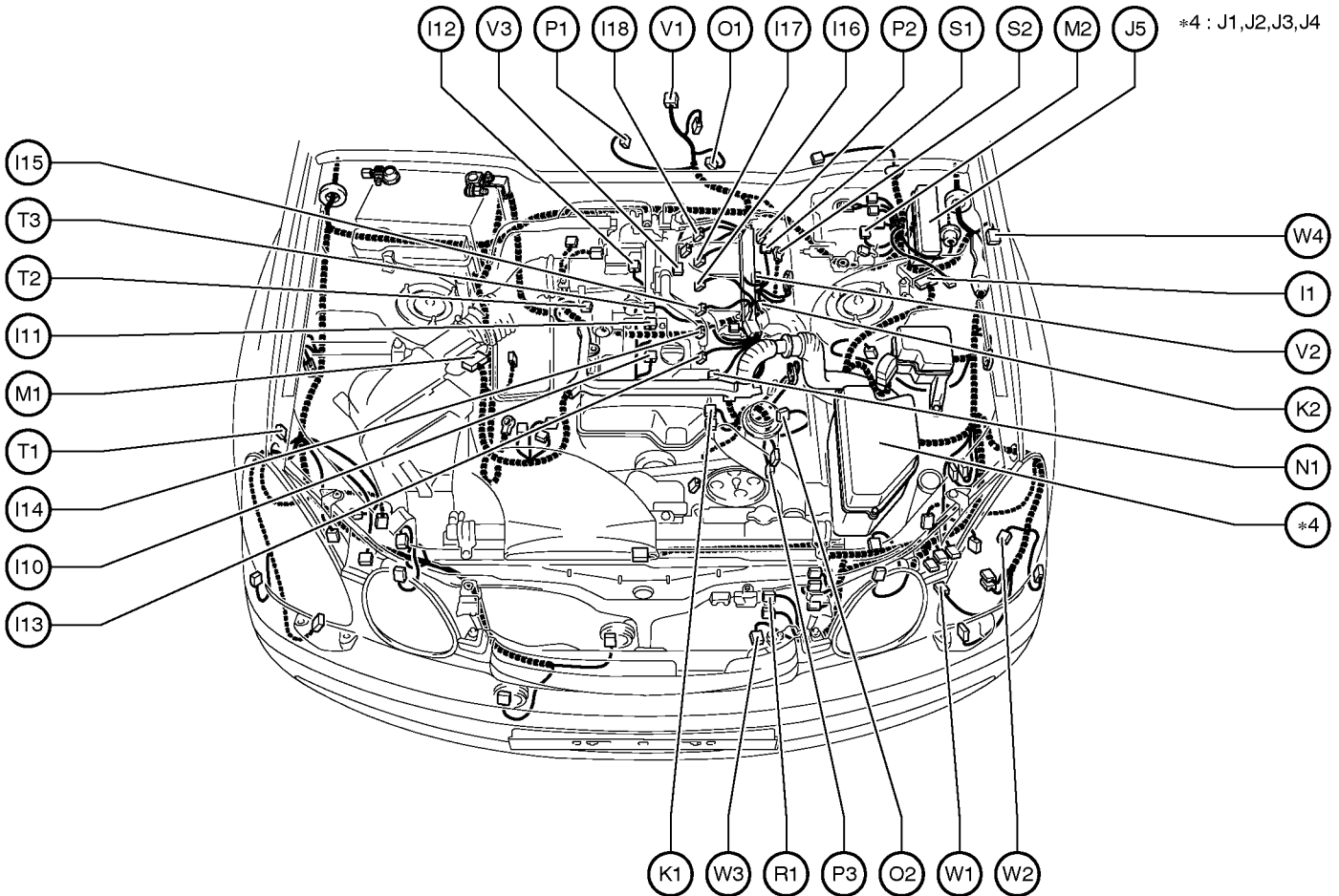

I 1 Igniter
 I 10 Ignition Coil No.1
 I 11 Ignition Coil No.2
 I 12 Ignition Coil No.3
 I 13 Injector No.1
 I 14 Injector No.2
 I 15 Injector No.3
 I 16 Injector No.4
 I 17 Injector No.5
 I 18 Injector No.6

J 1 Junction Connector
 J 2 Junction Connector
 J 3 Junction Connector
 J 4 Junction Connector
 J 5 Junction Connector

K 1 Knock Sensor 1
 K 2 Knock Sensor 2

M 1 Mass Air Flow Meter
 M 2 Master Cylinder Pressure Sensor

N 1 Noise Filter (Ignition)

O 1 O/D Direct Clutch Speed Sensor
 O 2 Oil Pressure SW

P 1 Park/Neutral Position SW
 P 2 Power Steering Oil Pressure SW
 P 3 PPS Solenoid

R 1 Radiator Fan Motor

S 1 Starter
 S 2 Starter

T 1 Theft Deterrent Horn
 T 2 Throttle Control Motor
 T 3 Throttle Position Sensor

V 1 Vehicle Speed Sensor (Electronically Controlled Transmission)

V 2 VSV (ACIS)
 V 3 VSV (EVAP)

W 1 Washer Level Warning SW
 W 2 Washer Motor
 W 3 Water Temp. SW
 W 4 Wireless Door Lock Buzzer

G ELECTRICAL WIRING ROUTING

Position of Parts in Instrument Panel

*1 : Except NAKAMICHI
*2 : NAKAMICHI

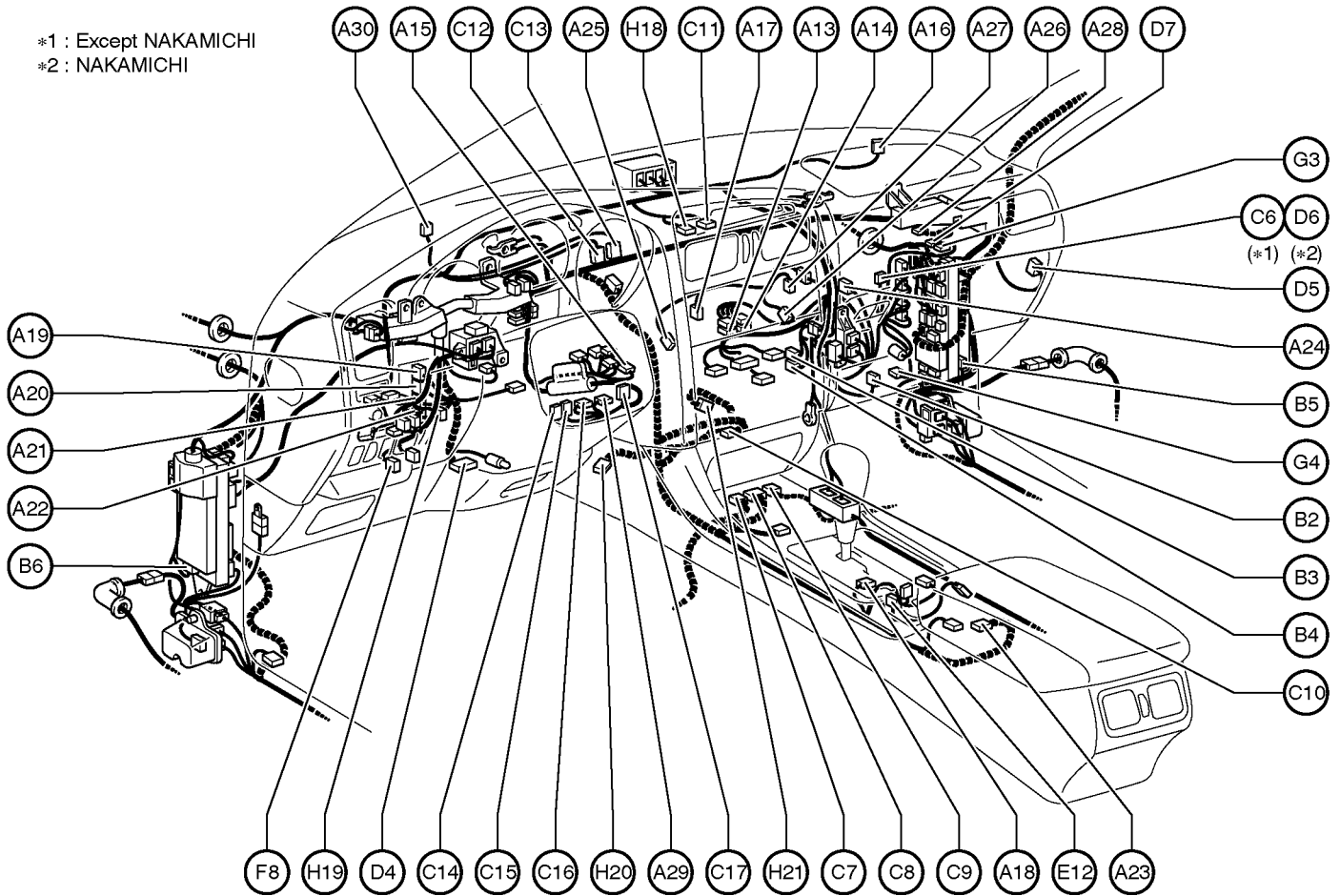

- A 13 A/C Control Assembly
- A 14 A/C Control Assembly
- A 15 A/C Room Temp. Sensor
- A 16 A/C Solar Sensor
- A 17 A/C Thermistor
- A 18 A/T Shift Position Illumination
- A 19 ABS & TRAC & VSC ECU
- A 20 ABS & TRAC & VSC ECU
- A 21 ABS & TRAC & VSC ECU
- A 22 ABS & TRAC & VSC ECU
- A 23 ABS Deceleration Sensor
- A 24 Air Inlet Control Servo Motor
- A 25 Air Mix Control Servo Motor (Driver Side)
- A 26 Air Mix Control Servo Motor (Front Passenger Side)
- A 27 Air Vent Mode Control Servo Motor
- A 28 Airbag Squib (Front Passenger Airbag Assembly)
- A 29 Airbag Squib (Steering Wheel Pad)
- A 30 Automatic Light Control Sensor

- B 2 Blower Motor
- B 3 Blower Motor Controller
- B 4 Blower Motor Controller
- B 5 Body ECU No.1
- B 6 Body ECU No.2

- C 6 CD Automatic Changer
- C 7 Center Airbag Sensor Assembly
- C 8 Center Airbag Sensor Assembly
- C 9 Center Airbag Sensor Assembly
- C 10 Cigarette Lighter
- C 11 Clock
- C 12 Combination Meter
- C 13 Combination Meter
- C 14 Combination SW
- C 15 Combination SW

- C 16 Combination SW
- C 17 Combination SW

- D 4 Data Link Connector 3
- D 5 Daytime Running Light Relay (Main)
- D 6 D/A Converter
- D 7 Diode (Daytime Running Light)

- E 12 Electronically Controlled Transmission Pattern Select SW

- F 8 Fuel Lid Opener SW

- G 3 Glove Box Light
- G 4 Glove Box Light SW

- H 18 Hazard SW
- H 19 Headlight Cleaner SW
- H 20 Heated Oxygen Sensor (Bank 1 Sensor 2)
[1UZ-FE]
- H 21 Heated Oxygen Sensor (Bank 2 Sensor 2)

Position of Parts in Instrument Panel

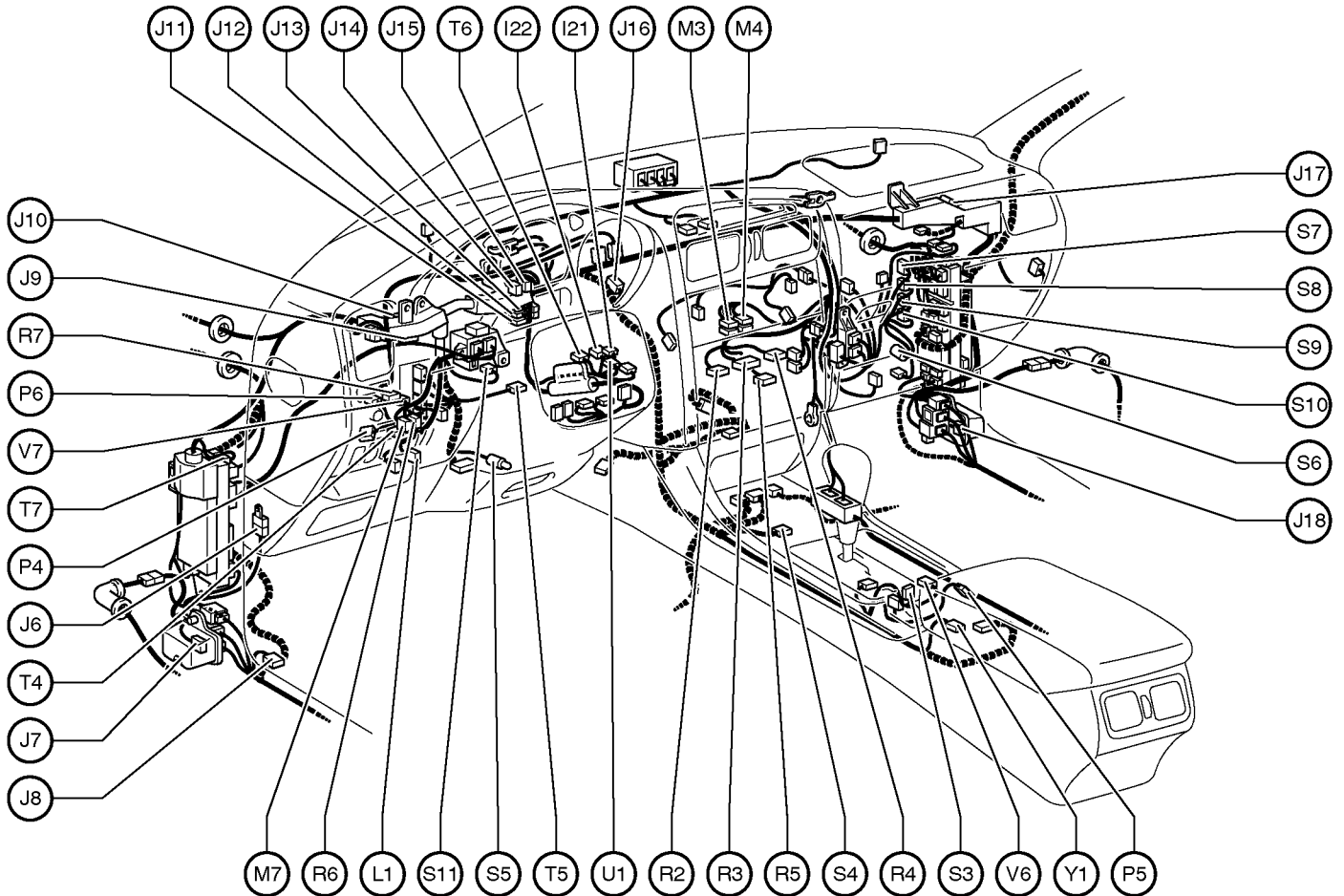

I 21 Ignition Key Cylinder Light
I 22 Ignition SW

J 6 Junction Connector
J 7 Junction Connector
J 8 Junction Connector
J 9 Junction Connector
J 10 Junction Connector
J 11 Junction Connector
J 12 Junction Connector
J 13 Junction Connector
J 14 Junction Connector
J 15 Junction Connector
J 16 Junction Connector
J 17 Junction Connector
J 18 Junction Connector

L 1 Luggage Compartment Door Opener SW

M 3 Multi-Display
M 4 Multi-Display
M 7 Mirror Retraction SW

P 4 Parking Brake SW
P 5 Power Outlet
P 6 PPS ECU

R 2 Radio and Player
R 3 Radio and Player
R 4 Radio and Player
R 5 Radio and Player
R 6 Remote Control Mirror SW
R 7 Rheostat

S 3 Seat Heater SW
S 4 Shift Lock Control ECU
S 5 Step Light LH
S 6 Step Light RH
S 7 Stereo Component Amplifier
S 8 Stereo Component Amplifier
S 9 Stereo Component Amplifier
S 10 Stereo Component Amplifier
S 11 Stop Light SW

T 4 Telephone Microphone
T 5 Tilt and Telescopic ECU
T 6 Transponder Key Amplifier
T 7 Turn Signal Flasher

U 1 Unlock Warning SW and Key Interlock Solenoid

V 6 VSC Off SW
V 7 VSC Warning Buzzer

Y 1 Yaw Rate Sensor

G ELECTRICAL WIRING ROUTING

Position of Parts in Body

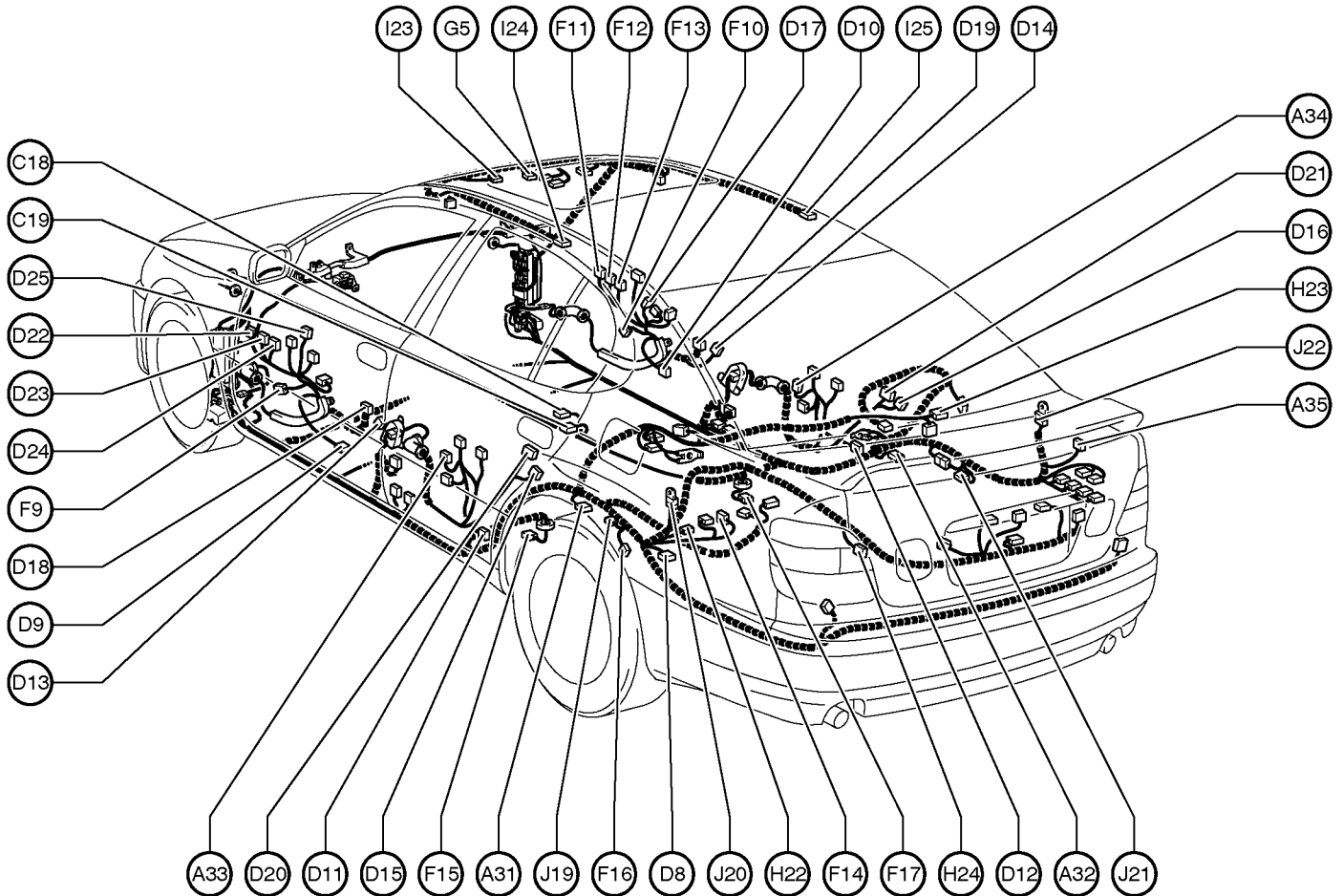

- A31 ABS Speed Sensor Rear LH
- A32 ABS Speed Sensor Rear RH
- A33 Ashtray Illumination Rear LH
- A34 Ashtray Illumination Rear RH
- A35 Auto Antenna Control Relay and Motor

- C18 Cellular Phone (Hand Set)
- C19 Cellular Phone (Hand Set)

- D 8 Diode (Luggage Compartment Door Open Detection)
- D 9 Door Courtesy Light Front LH
- D10 Door Courtesy Light Front RH
- D11 Door Courtesy Light Rear LH
- D12 Door Courtesy Light Rear RH
- D13 Door Courtesy SW Front LH
- D14 Door Courtesy SW Front RH
- D15 Door Courtesy SW Rear LH
- D16 Door Courtesy SW Rear RH
- D17 Door Lock Control SW RH
- D18 Door Lock Motor , Door Key Lock and Unlock SW and Door Lock Detection SW Front LH
- D19 Door Lock Motor , Door Key Lock and Unlock SW and Door Lock Detection SW Front RH
- D20 Door Lock Motor and Door Lock Detection SW Rear LH
- D21 Door Lock Motor and Door Lock Detection SW Rear RH
- D22 Driver Door ECU
- D23 Driver Door ECU
- D24 Driver Door ECU
- D25 Driving Position Memory SW

- F 9 Front Door Speaker LH
- F10 Front Door Speaker RH
- F11 Front Passenger Door ECU
- F12 Front Passenger Door ECU
- F13 Front Passenger Door ECU
- F14 Fuel Lid Opener Motor
- F15 Fuel Pump and Sender
- F16 Fuel Pump Control ECU
- F17 Fuel Sender (Sub)

- G 5 Garage Door Opener

- H22 Height Control Sensor (Rear)
- H23 High Mounted Stop Light (Bulb)
- H24 High Mounted Stop Light (LED)

- I 23 Inner Mirror
- I 24 Interior Light Rear LH
- I 25 Interior Light Rear RH

- J 19 Junction Connector
- J 20 Junction Connector
- J 21 Junction Connector
- J 22 Junction Connector

Position of Parts in Body

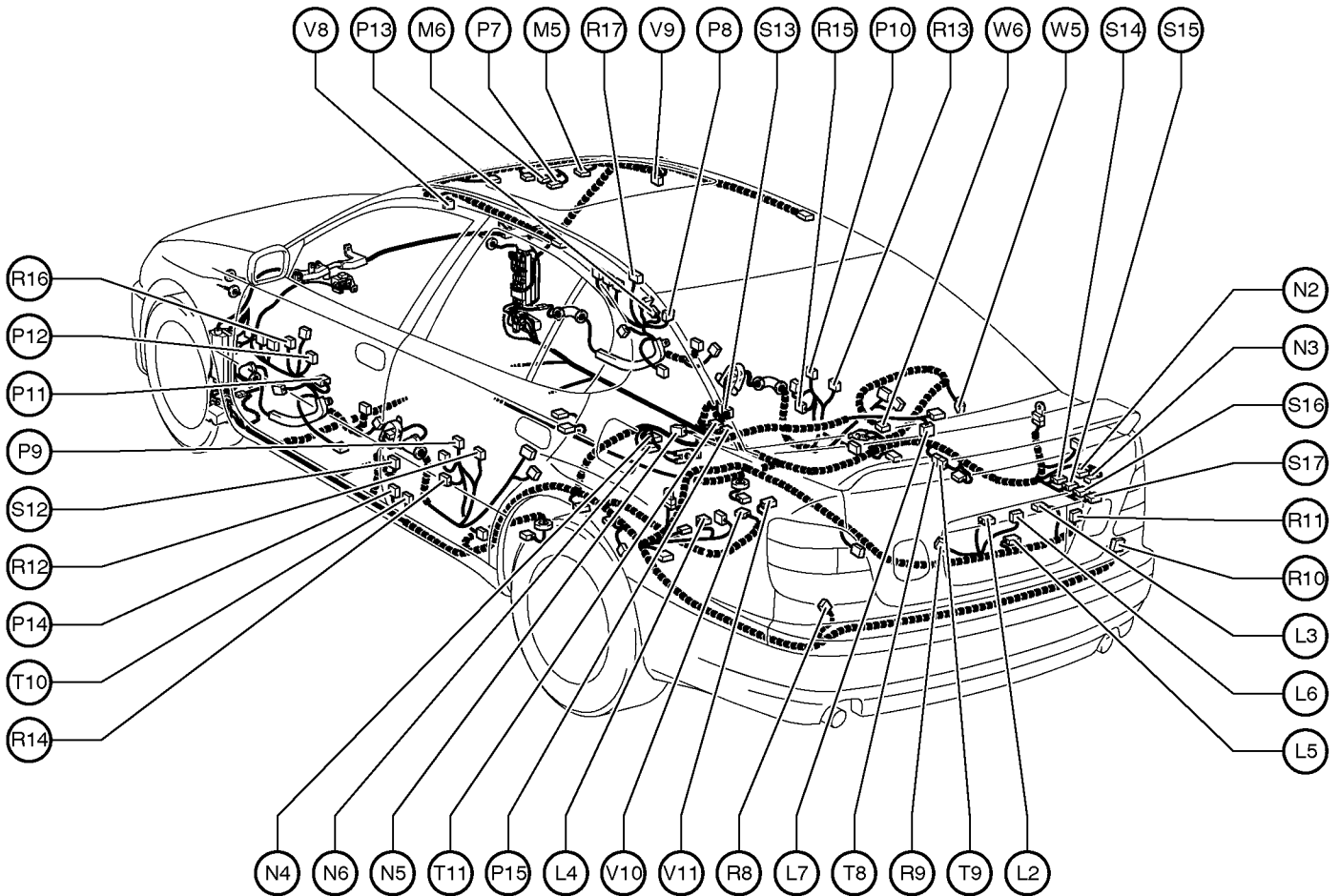

L 2 License Plate Light LH
 L 3 License Plate Light RH
 L 4 Light Failure Sensor
 L 5 Luggage Compartment Door Courtesy SW and Opener Motor
 L 6 Luggage Compartment Door Key Unlock SW
 L 7 Luggage Compartment Light

M 5 Moon Roof Control ECU
 M 6 Moon Roof Control SW

N 2 Navigation ECU
 N 3 Navigation ECU
 N 4 Noise Filter (High Mounted Stop Light)
 N 5 Noise Filter (Rear Window Defogger)
 N 6 Noise Filter (Stop Light)

P 7 Personal Light
 P 8 Power Window Control SW Front RH
 P 9 Power Window Control SW Rear LH
 P 10 Power Window Control SW Rear RH
 P 11 Power Window Master SW
 P 12 Power Window Motor Front LH
 P 13 Power Window Motor Front RH
 P 14 Pretensioner LH
 P 15 Pretensioner RH

R 8 Rear Combination Light LH
 R 9 Rear Combination Light LH
 R 10 Rear Combination Light RH
 R 11 Rear Combination Light RH
 R 12 Rear Door LH ECU
 R 13 Rear Door RH ECU
 R 14 Rear Door Speaker LH
 R 15 Rear Door Speaker RH

R 16 Remote Control Mirror LH
 R 17 Remote Control Mirror RH

S 12 Side Airbag Sensor LH
 S 13 Side Airbag Sensor RH
 S 14 Stereo Component Amplifier
 S 15 Stereo Component Amplifier
 S 16 Stereo Component Amplifier
 S 17 Stereo Component Amplifier

T 8 Telephone Transceiver and Speaker Relay
 T 9 Telephone Transceiver and Speaker Relay
 T 10 Tension Reducer Solenoid LH
 T 11 Tension Reducer Solenoid RH

V 8 Vanity Light LH
 V 9 Vanity Light RH
 V 10 Vapor Pressure Sensor
 V 11 VSV (Vapor Pressure Sensor)

W 5 Wireless Door Lock Control ECU
 W 6 Woofer (Speaker)

G ELECTRICAL WIRING ROUTING

Position of Parts in Seat

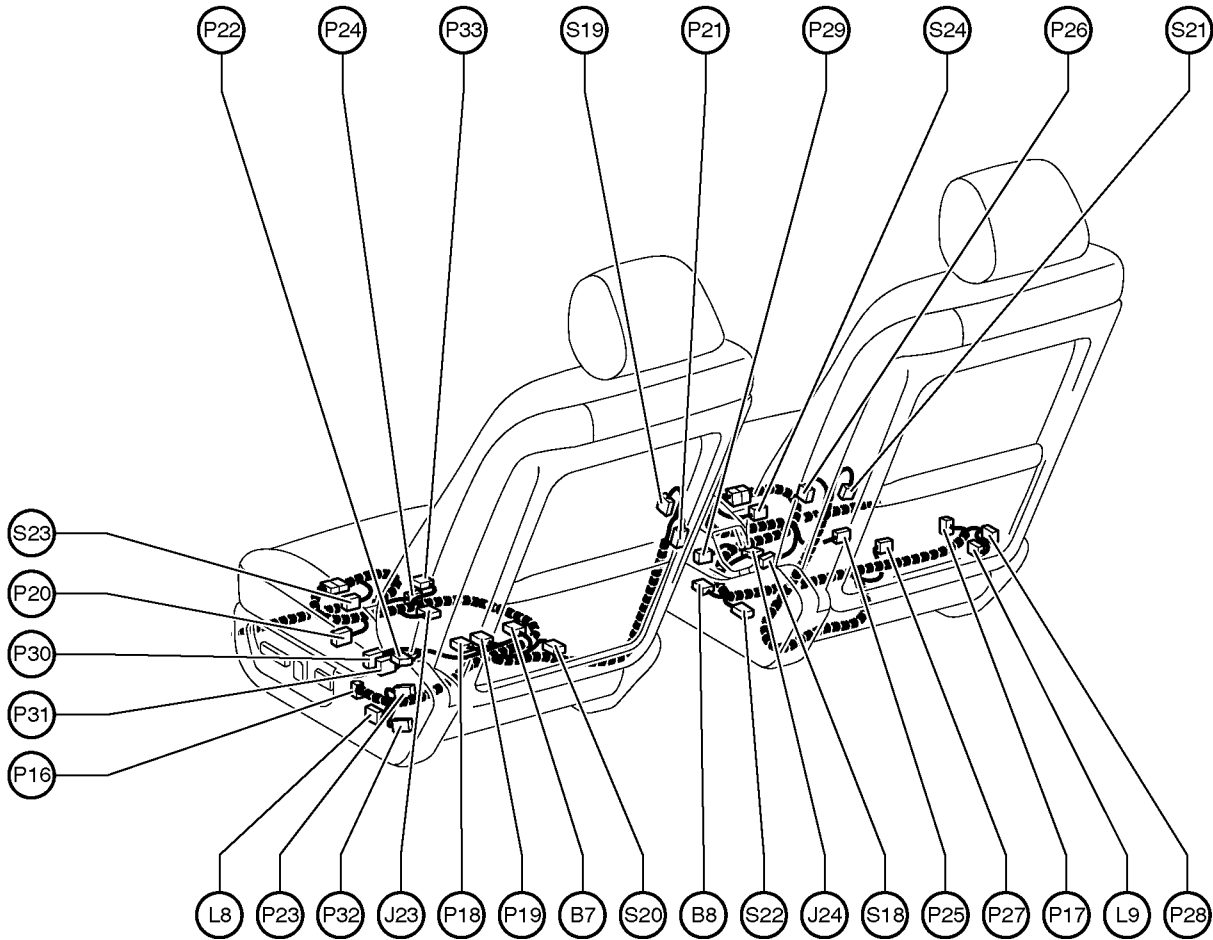

B 7 Buckle SW LH
B 8 Buckle SW RH

J 23 Junction Connector
J 24 Junction Connector

L 8 Lumbar Support Control SW (Driver's Seat)
L 9 Lumbar Support Control SW (Front Passenger's Seat)

P 16 Power Seat Control SW (Driver's Seat)
P 17 Power Seat Control SW (Front Passenger's Seat)
P 18 Power Seat ECU
P 19 Power Seat ECU
P 20 Power Seat Motor (Driver's Seat Front Vertical Control)
P 21 Power Seat Motor (Driver's Seat Lumbar Support Control)
P 22 Power Seat Motor (Driver's Seat Rear Vertical Control)
P 23 Power Seat Motor (Driver's Seat Reclining Control)
P 24 Power Seat Motor (Driver's Seat Slide Control)
P 25 Power Seat Motor (Front Passenger's Seat Front Vertical Control)
P 26 Power Seat Motor (Front Passenger's Seat Lumbar Support Control)
P 27 Power Seat Motor (Front Passenger's Seat Rear Vertical Control)
P 28 Power Seat Motor (Front Passenger's Seat Reclining Control)
P 29 Power Seat Motor (Front Passenger's Seat Slide Control)
P 30 Power Seat Position Sensor (Driver's Seat Front Vertical Control)
P 31 Power Seat Position Sensor (Driver's Seat Rear Vertical Control)

P 32 Power Seat Position Sensor (Driver's Seat Reclining Control)
P 33 Power Seat Position Sensor (Driver's Seat Slide Control)

S 18 Seat Belt Warning Occupant Detection Sensor
S 19 Seat Heater (Driver's Seat Back)
S 20 Seat Heater (Driver's Seat Cushion)
S 21 Seat Heater (Front Passenger's Seat Back)
S 22 Seat Heater (Front Passenger's Seat Cushion)
S 23 Side Airbag Squib LH
S 24 Side Airbag Squib RH

G ELECTRICAL WIRING ROUTING

□ : Location of Connector Joining Wire Harness and Wire Harness

▽ : Location of Ground Points

[1UZ-FE]

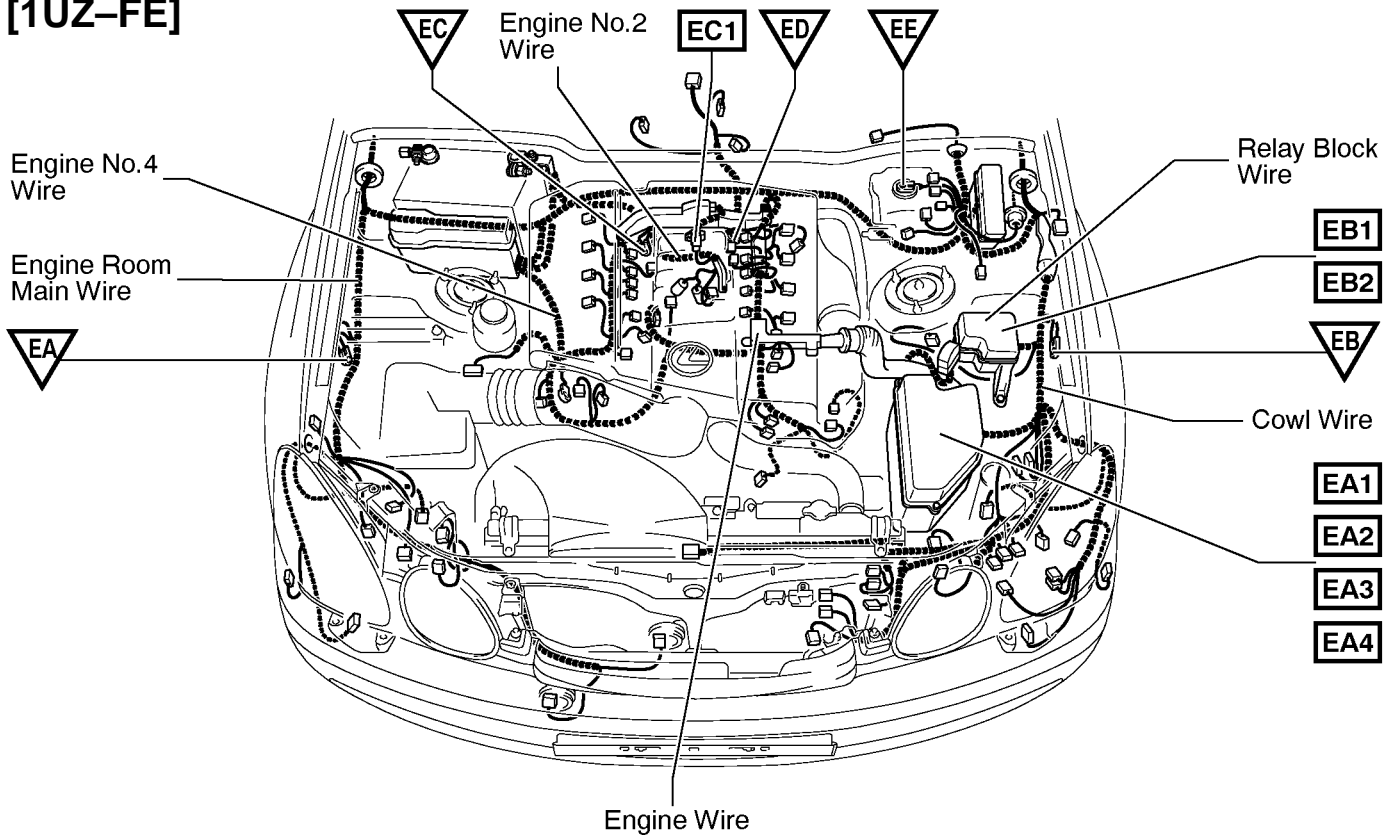

○ : Location of Splice Points

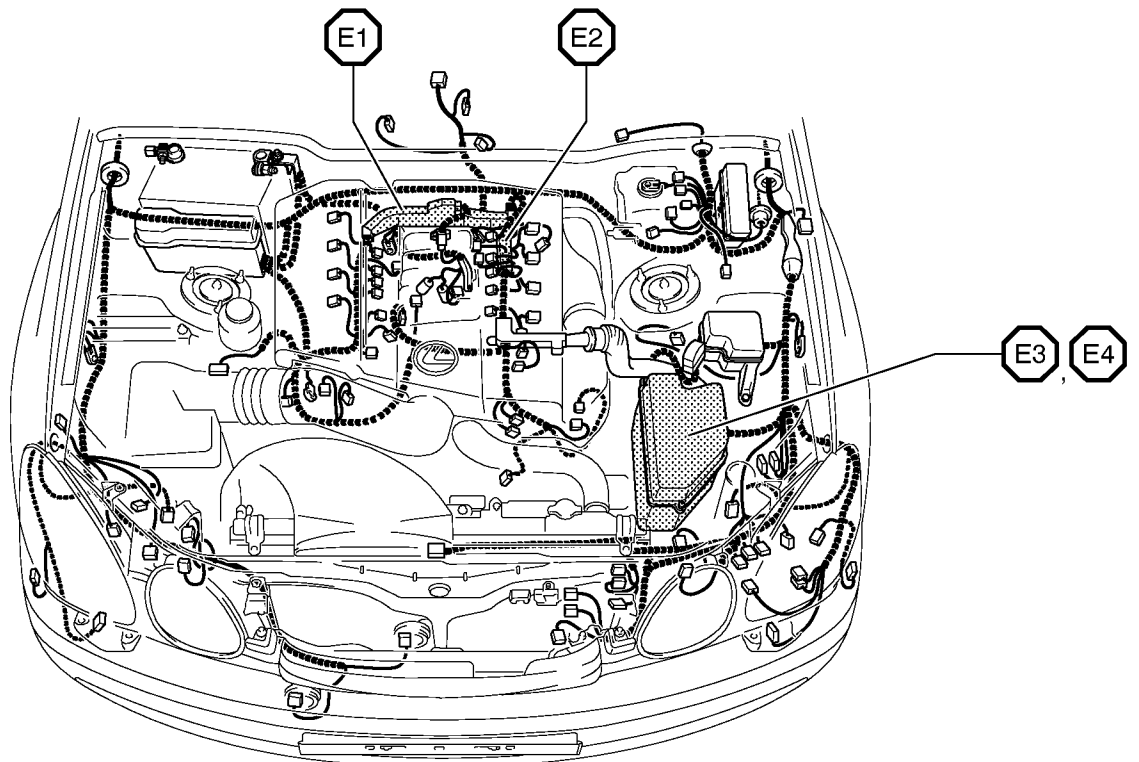

Connector Joining Wire Harness and Wire Harness

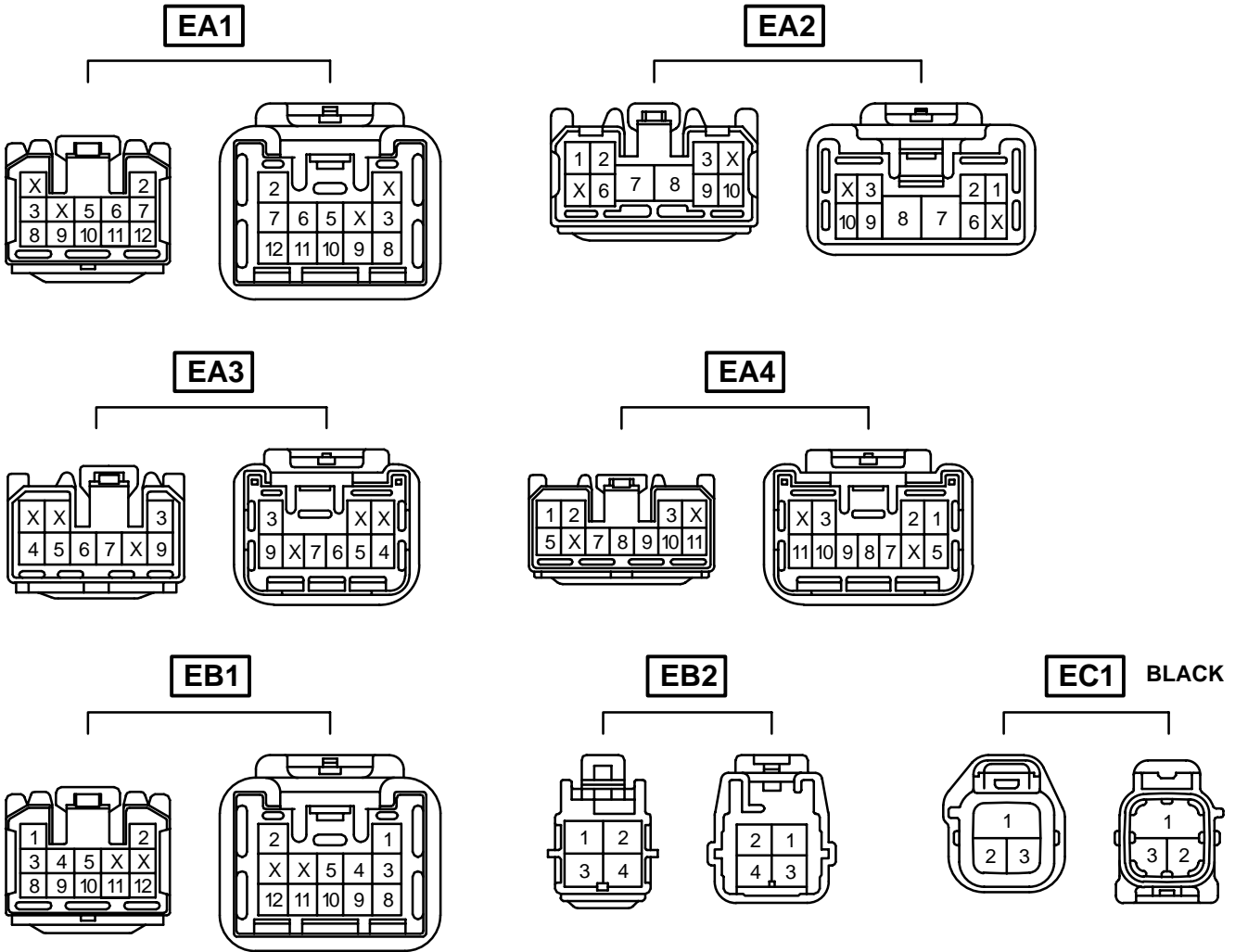

Code	Joining Wire Harness and Wire Harness (Connector Location)
EA1	Engine Wire and Cowl Wire (Inside of the ECU Box)
EA2	
EA3	
EA4	
EB1	Cowl Wire and Relay Block Wire (Inside of the Engine Room No.3 R/B)
EB2	
EC1	Engine No.2 Wire and Engine Wire (Near the Starter)

G ELECTRICAL WIRING ROUTING

□ : Location of Connector Joining Wire Harness and Wire Harness

▽ : Location of Ground Points

[2JZ-GE]

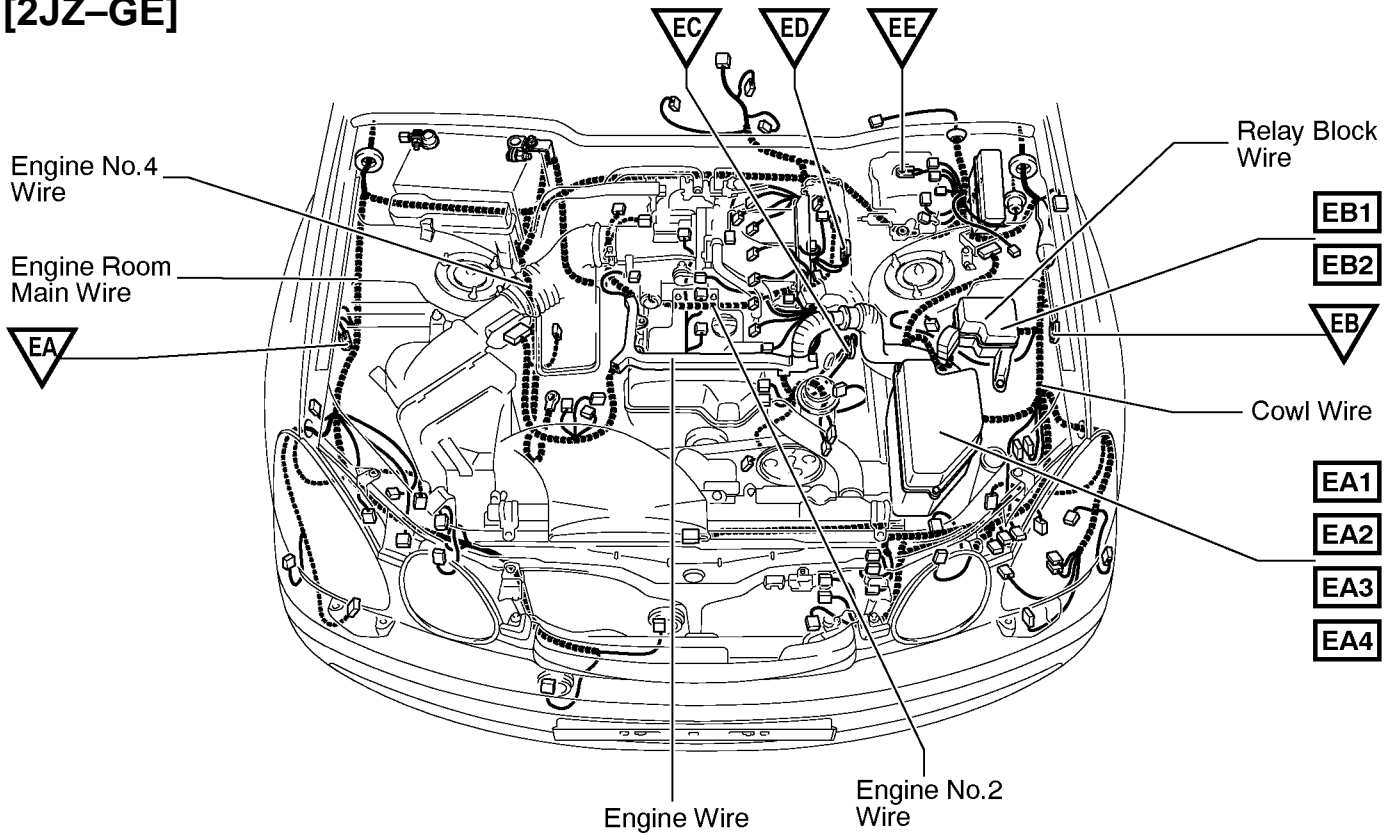

○ : Location of Splice Points

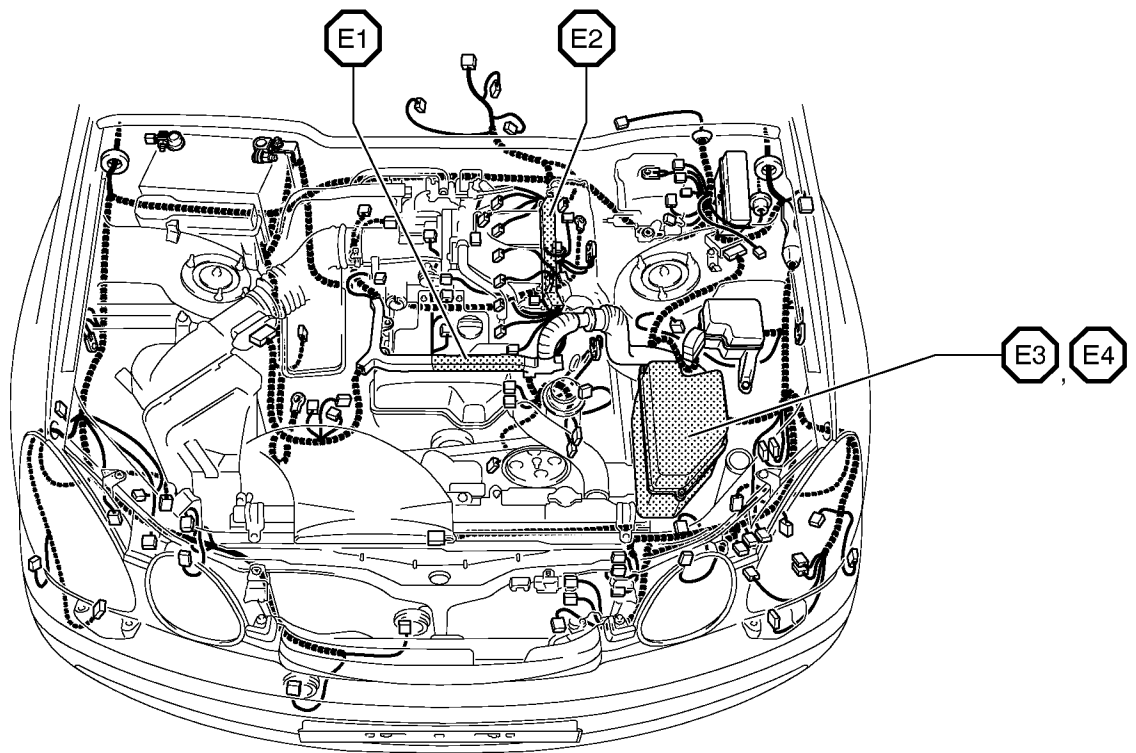

Connector Joining Wire Harness and Wire Harness

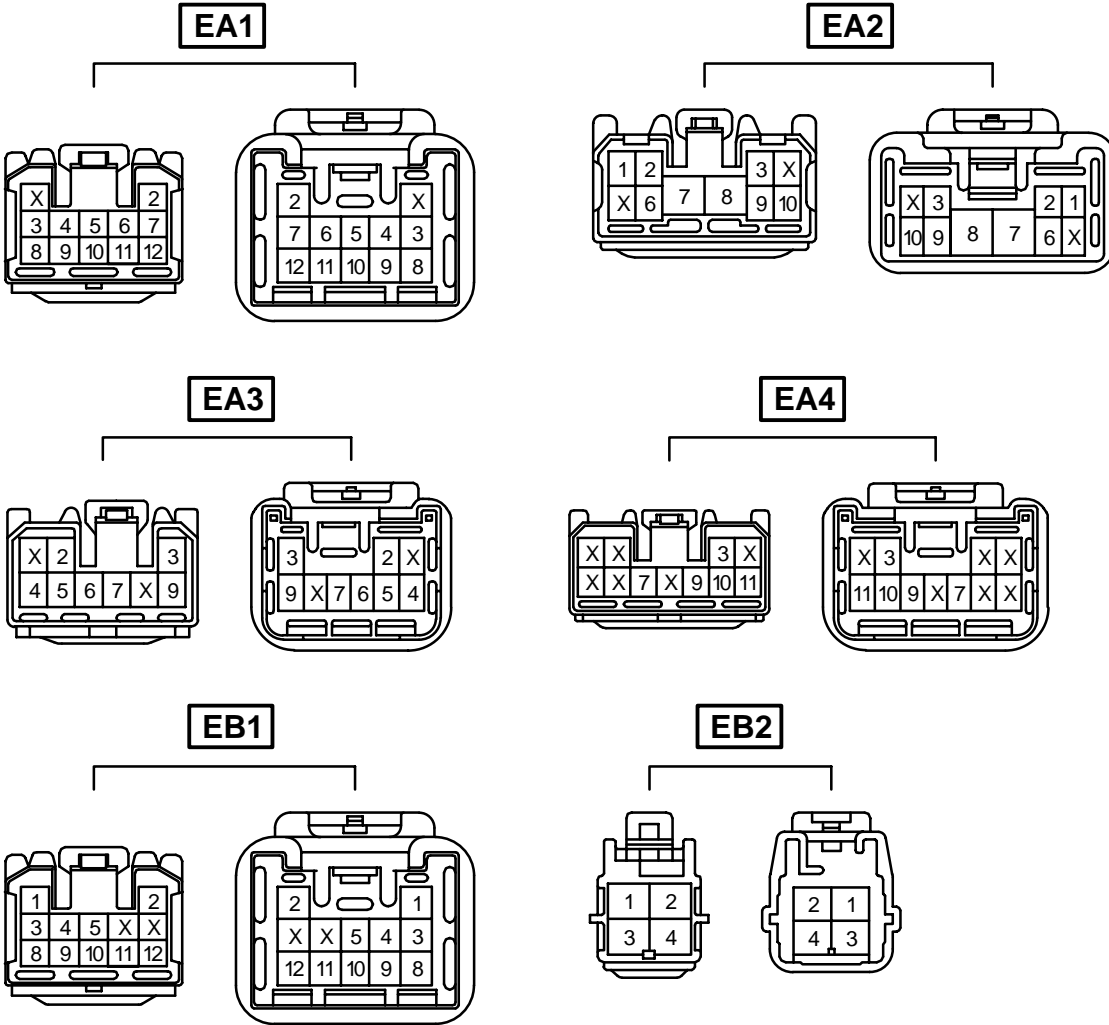

Code	Joining Wire Harness and Wire Harness (Connector Location)
EA1	Engine Wire and Cowl Wire (Inside of the ECU Box)
EA2	
EA3	
EA4	
EB1	Cowl Wire and Relay Block Wire (Inside of the Engine Room No.3 R/B)
EB2	

G ELECTRICAL WIRING ROUTING

□ : Location of Connector Joining Wire Harness and Wire Harness

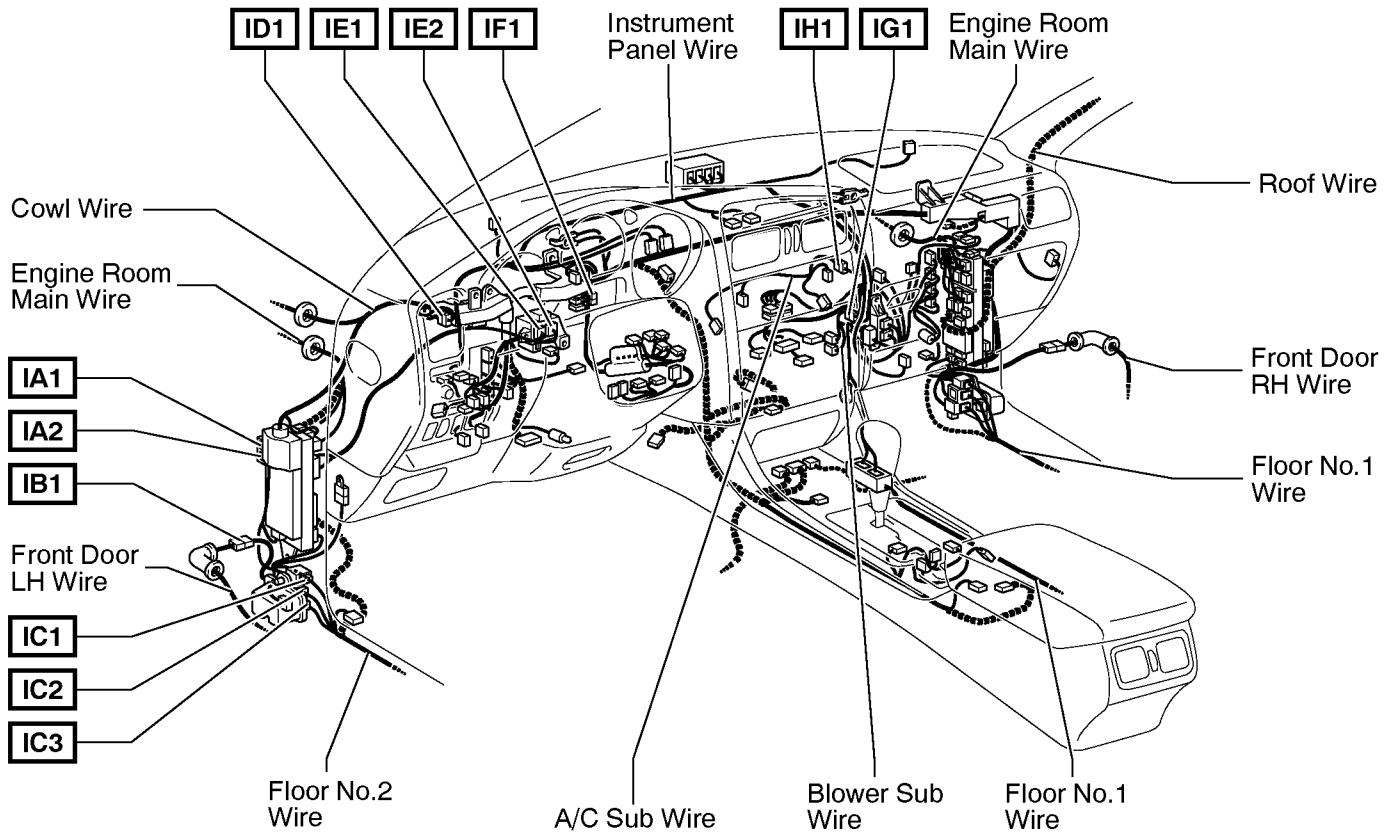

▽ : Location of Ground Points

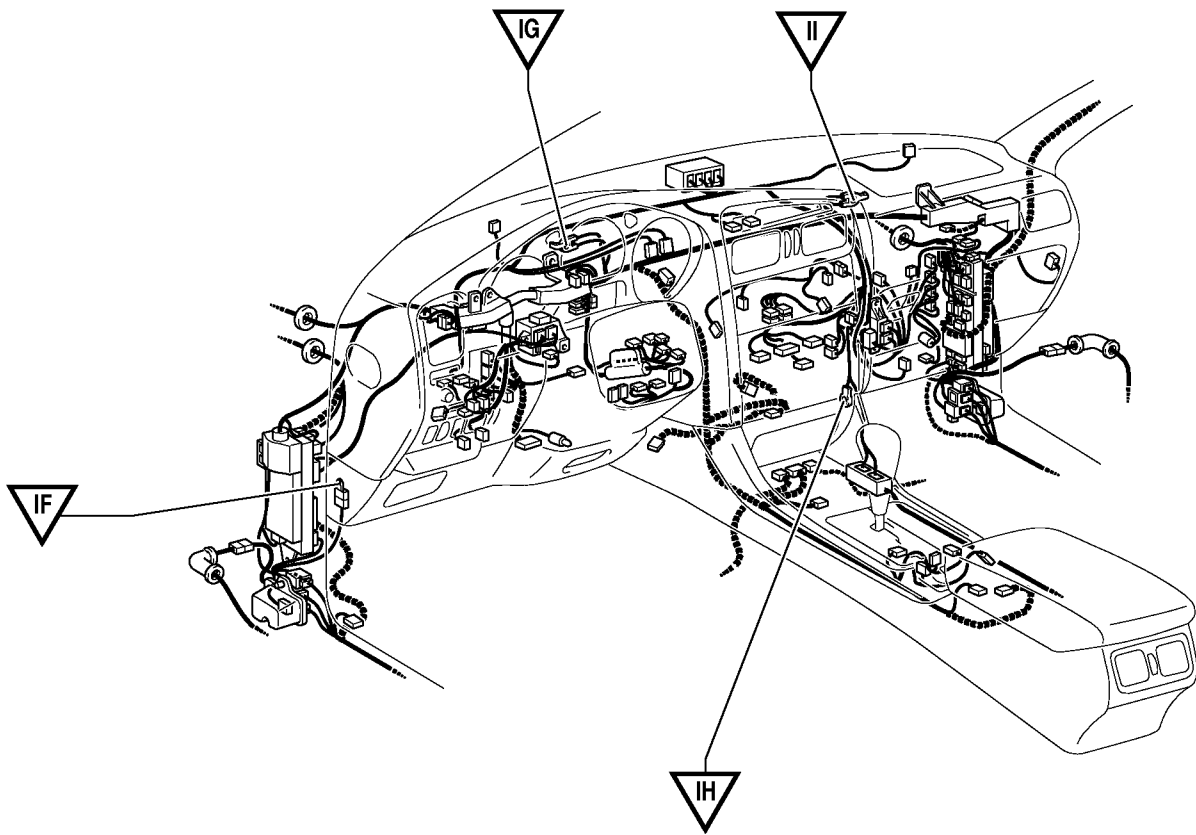

Connector Joining Wire Harness and Wire Harness

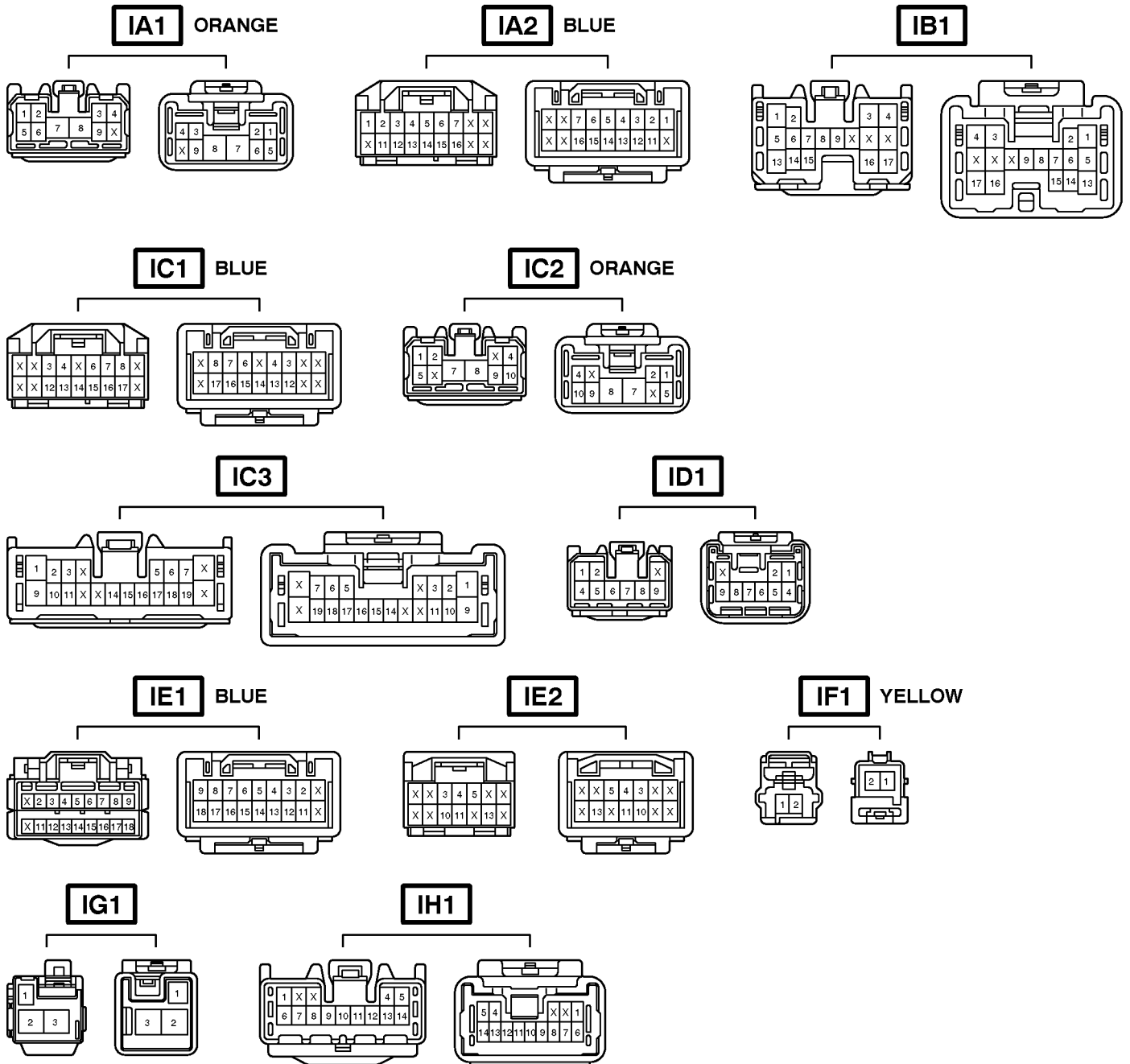

Code	Joining Wire Harness and Wire Harness (Connector Location)
IA1	Engine Room Main Wire and Cowl Wire (Near the Driver Side J/B)
IA2	Engine Room Main Wire and Cowl Wire (Near the Driver Side J/B)
IB1	Front Door LH Wire and Cowl Wire (Left Kick Panel)
IC1	Floor No.2 Wire and Cowl Wire (Left Kick Panel)
IC2	
IC3	
ID1	Cowl Wire and Cowl Wire (Left Side of the Instrument Panel Reinforcement)
IE1	Instrument Panel Wire and Cowl Wire (Left Side of the Steering Column)
IE2	
IF1	Cowl Wire and Cowl Wire (Right Side of the Steering Column)
IG1	Cowl Wire and Blower Sub Wire (Left Side of the Blower Unit)
IH1	Instrument Panel Wire and A/C Sub Wire (Left Side of the Blower Unit)

G ELECTRICAL WIRING ROUTING

□ : Location of Connector Joining Wire Harness and Wire Harness

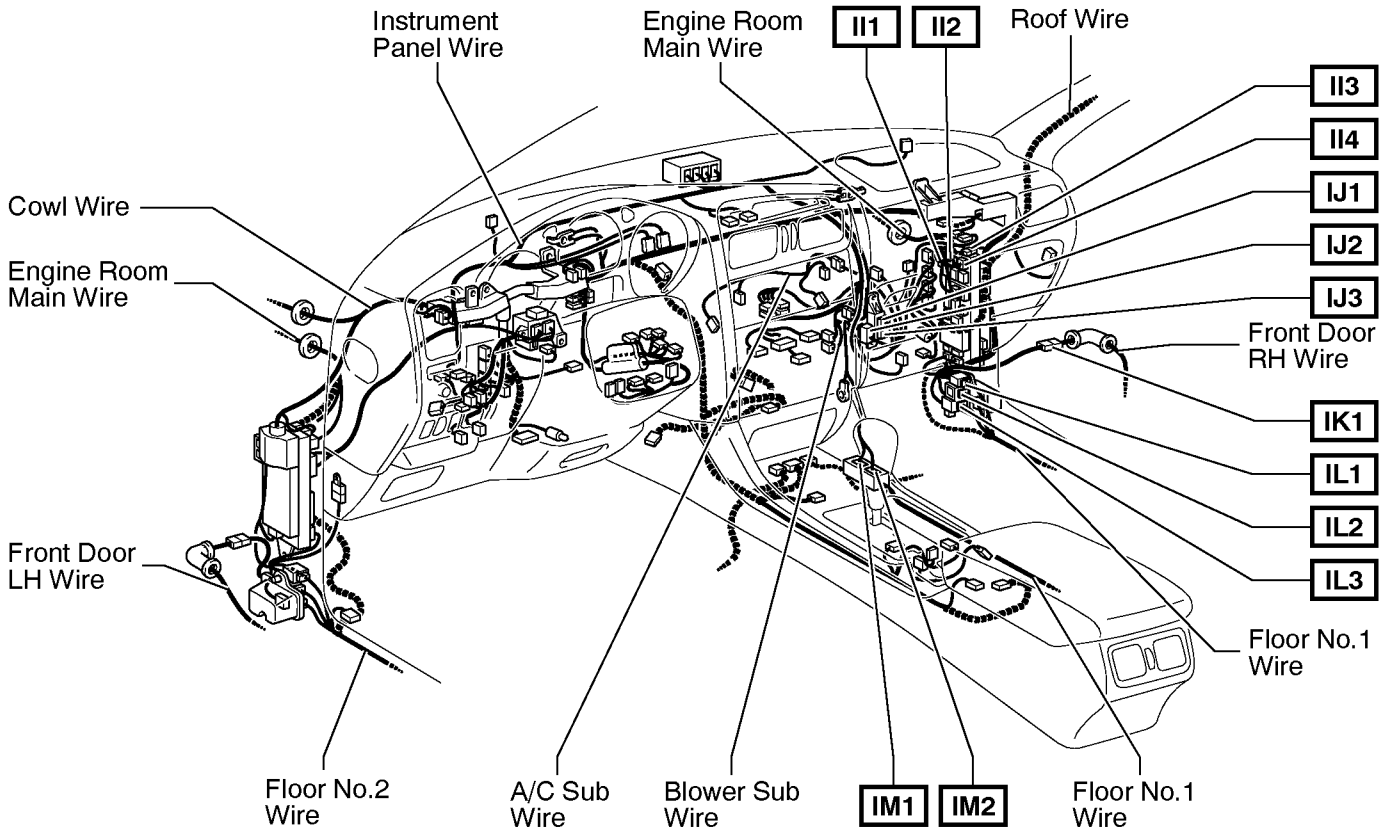

○ : Location of Splice Points

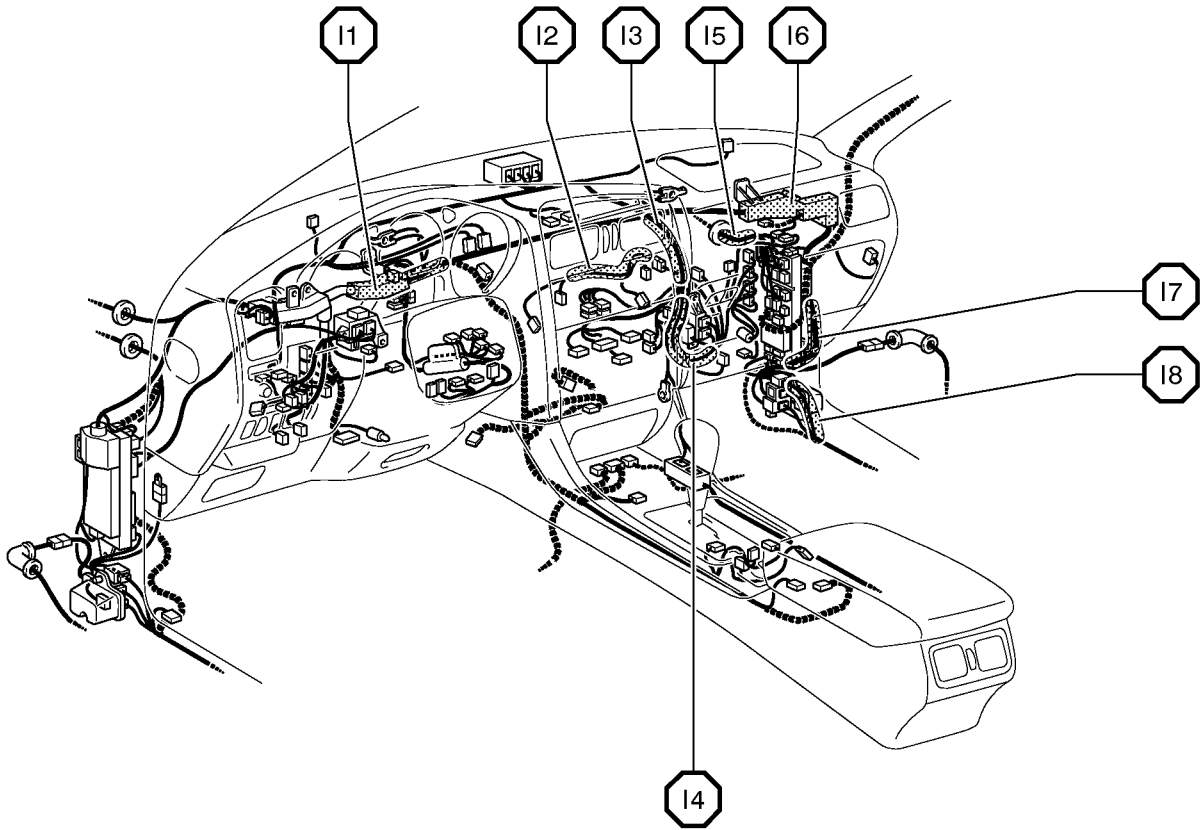

Connector Joining Wire Harness and Wire Harness

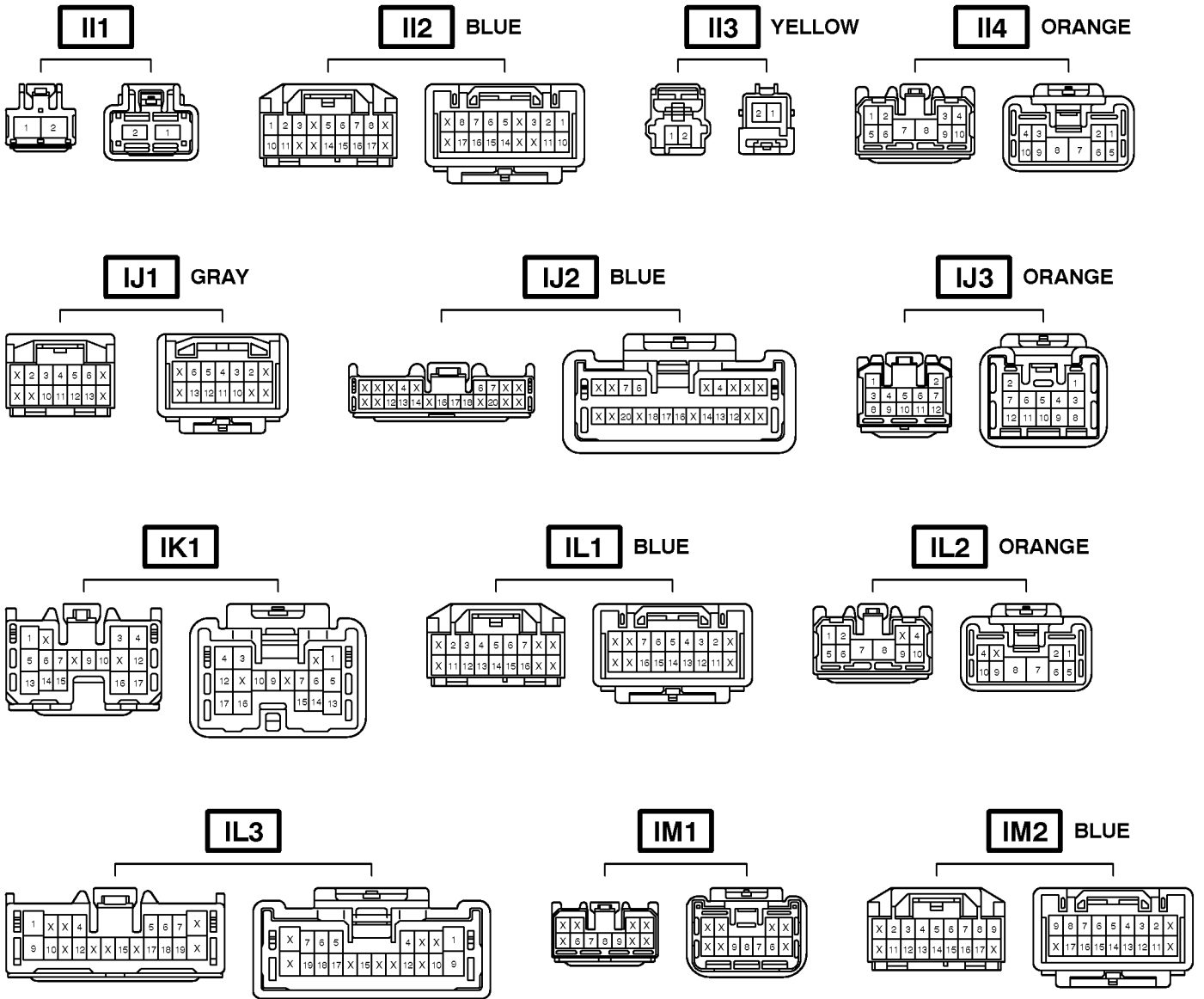

Code	Joining Wire Harness and Wire Harness (Connector Location)
II1	Engine Room Main Wire and Cowl Wire (Near the Passenger Side R/B)
II2	
II3	
II4	
IJ1	Instrument Panel Wire and Cowl Wire (Left Side of the Blower Unit)
IJ2	
IJ3	
IK1	Front Door RH Wire and Cowl Wire (Right Kick Panel)
IL1	Floor No.1 Wire and Cowl Wire (Right Kick Panel)
IL2	
IL3	
IM1	Instrument Panel Wire and Floor No.1 Wire (Front RH Side of the Shift Lever)
IM2	

G ELECTRICAL WIRING ROUTING

□ : Location of Connector Joining Wire Harness and Wire Harness
 ▽ : Location of Ground Points

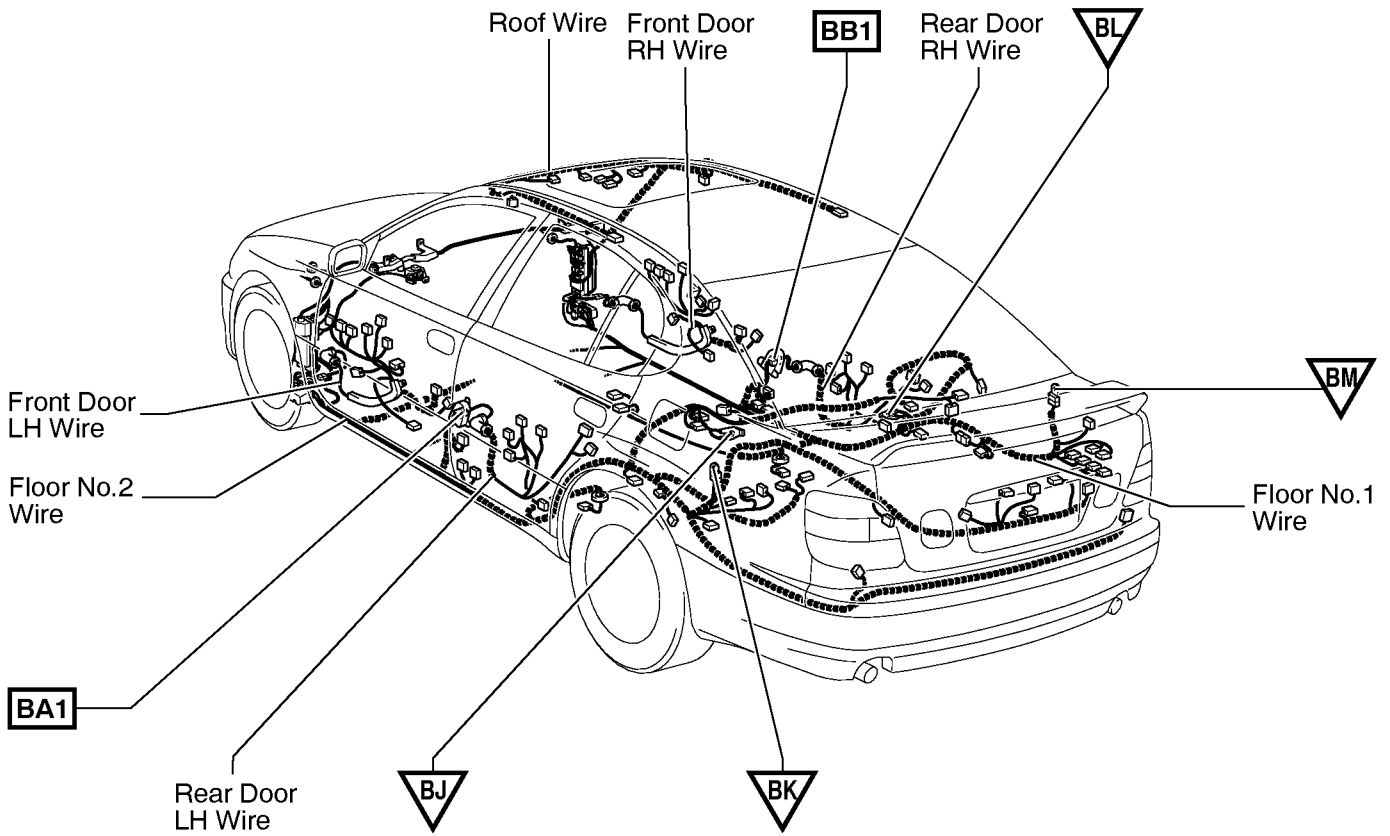

○ : Location of Splice Points

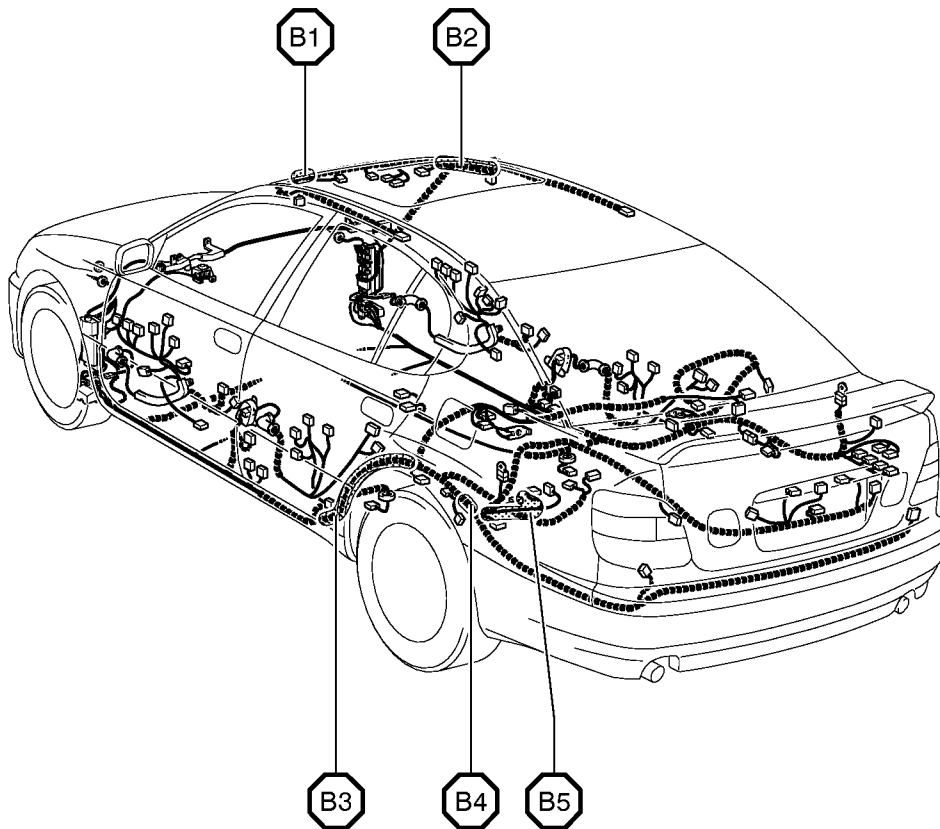

Connector Joining Wire Harness and Wire Harness

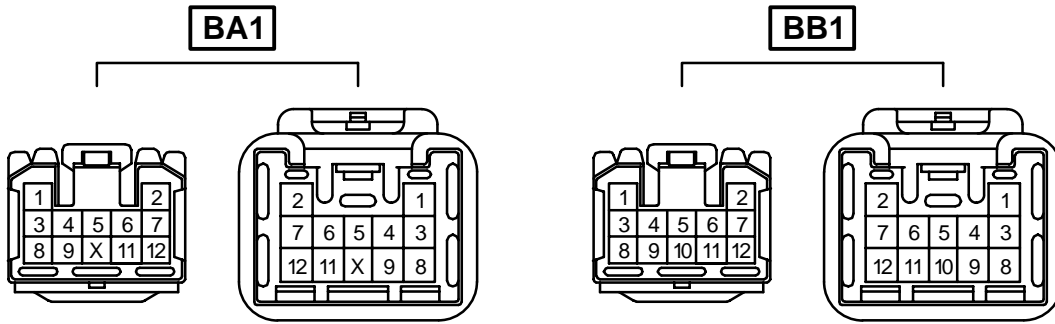

Code	Joining Wire Harness and Wire Harness (Connector Location)
BA1	Rear Door LH Wire and Floor No.2 Wire (Under the Center Pillar LH)
BB1	Rear Door RH Wire and Floor No.1 Wire (Under the Center Pillar RH)

G ELECTRICAL WIRING ROUTING

□ : Location of Connector Joining Wire Harness and Wire Harness

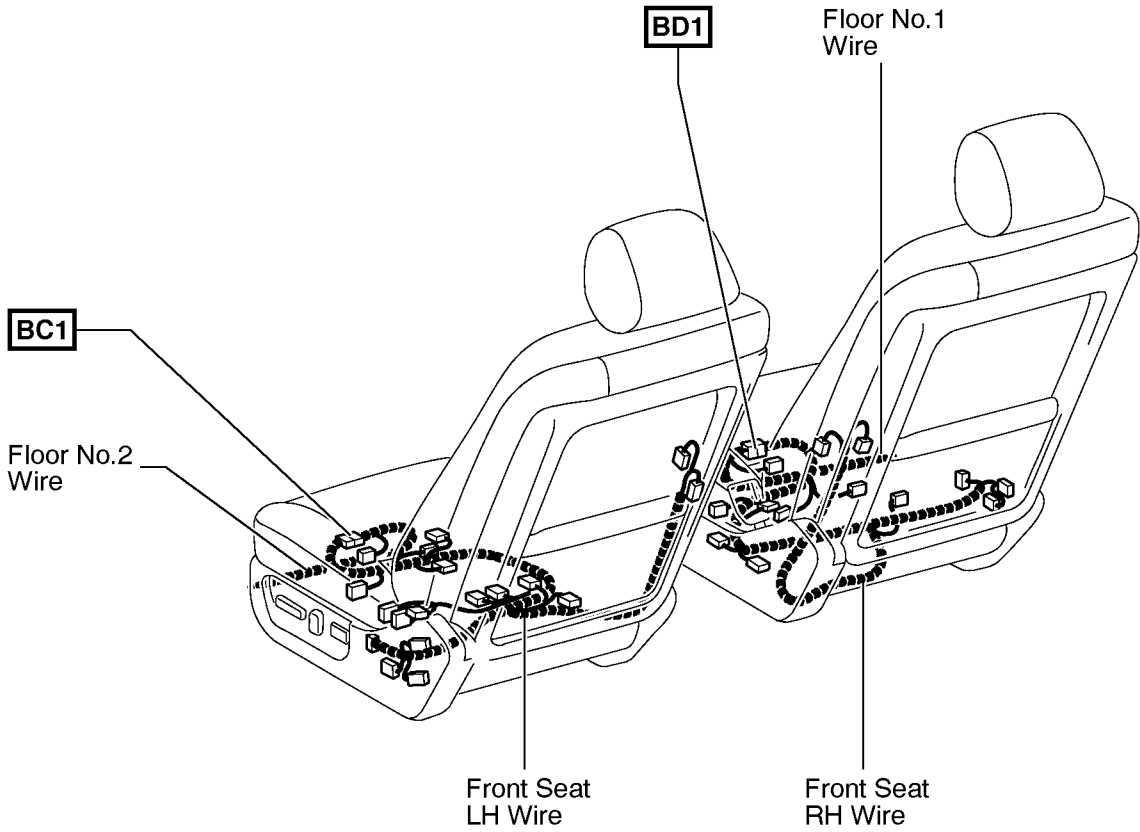

○ : Location of Splice Points

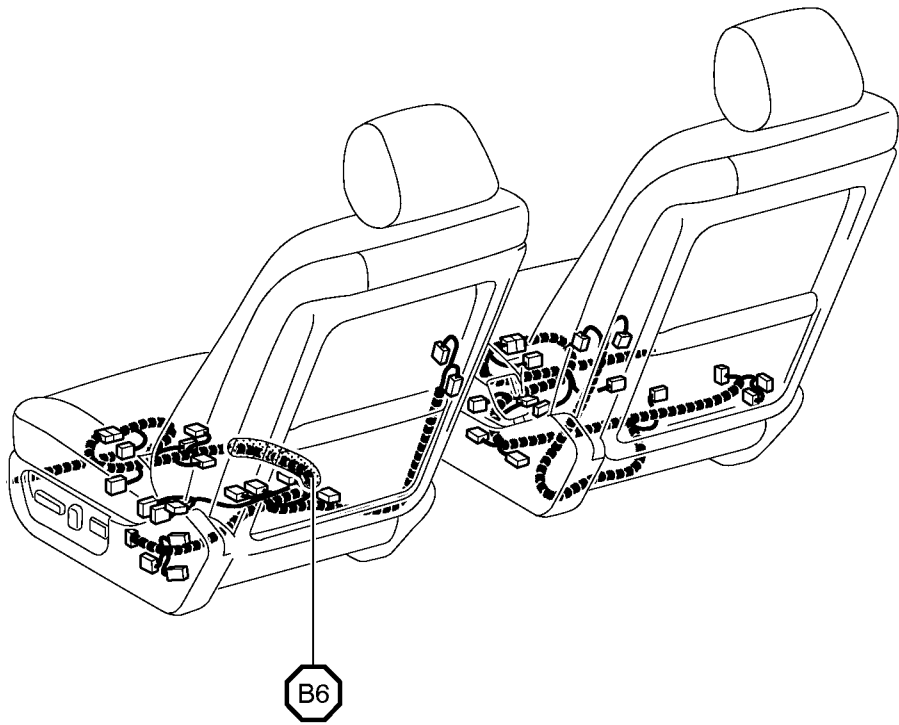

Connector Joining Wire Harness and Wire Harness

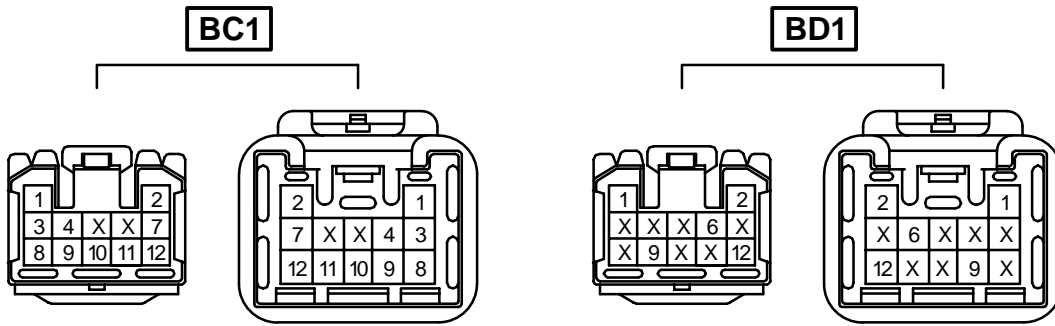

Code	Joining Wire Harness and Wire Harness (Connector Location)
BC1	Floor No.2 Wire and Front Seat LH Wire (Under the Driver's Seat)
BD1	Floor No.1 Wire and Front Seat RH Wire (Under the Front Passenger's Seat)

AUTO ANTENNA

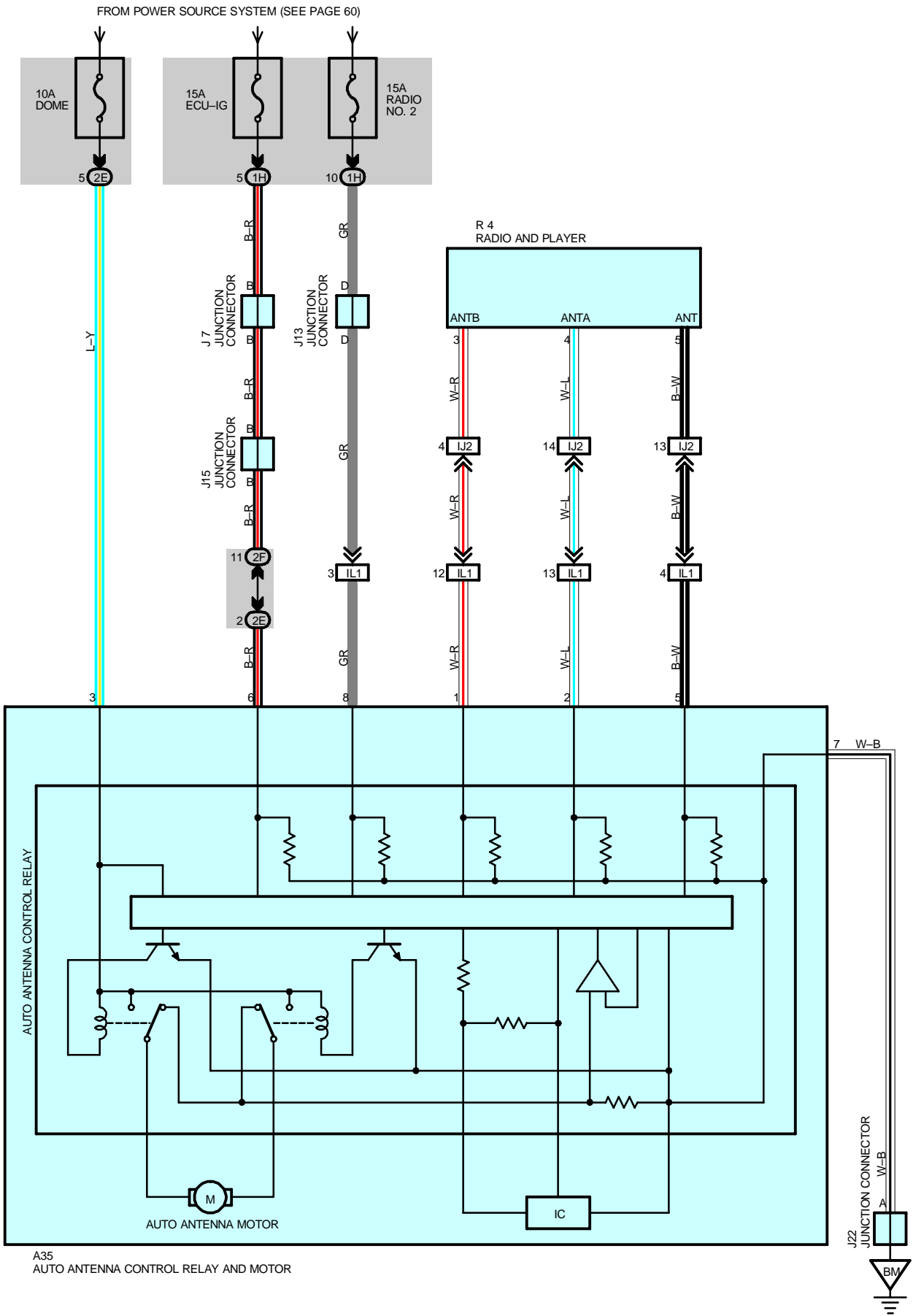

A35
AUTO ANTENNA CONTROL RELAY AND MOTOR

SERVICE HINTS

A35 AUTO ANTENNA CONTROL RELAY AND MOTOR

- 3-GROUND : Always approx. **12** volts
- 6-GROUND : Approx. **12** volts with ignition SW at **ON** position
- 8-GROUND : Approx. **12** volts with ignition SW at **ACC** or **ON** position
- 7-GROUND : Always continuity

○ : PARTS LOCATION

Code	See Page	Code	See Page	Code	See Page
A35	42	J13	41	J22	42
J7	41	J15	41	R4	41

○ : JUNCTION BLOCK AND WIRE HARNESS CONNECTOR

Code	See Page	Junction Block and Wire Harness (Connector Location)
1H	27	Cowl Wire and Driver Side J/B (Left Kick Panel)
2E	28	Floor No.1 Wire and Passenger Side J/B (Right Kick Panel)
2F	28	Cowl Wire and Passenger Side J/B (Right Kick Panel)

□ : CONNECTOR JOINING WIRE HARNESS AND WIRE HARNESS

Code	See Page	Joining Wire Harness and Wire Harness (Connector Location)
IJ2	52	Instrument Panel Wire and Cowl Wire Left Side of the Blower Unit
IL1	52	Floor No.1 Wire and Cowl Wire Right Kick Panel

▽ : GROUND POINTS

Code	See Page	Ground Points Location
BM	54	Quarter Panel RH

A35



J7
GRAY

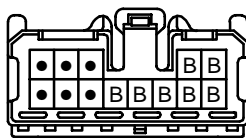

(Hint : See Page 7)

J13

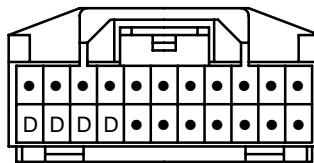

(Hint : See Page 7)

J15

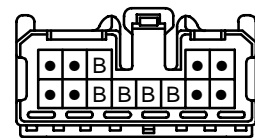

(Hint : See Page 7)

J22

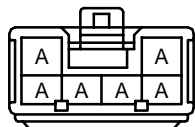

(Hint : See Page 7)

R4

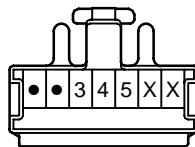

AUTOMATIC AIR CONDITIONING

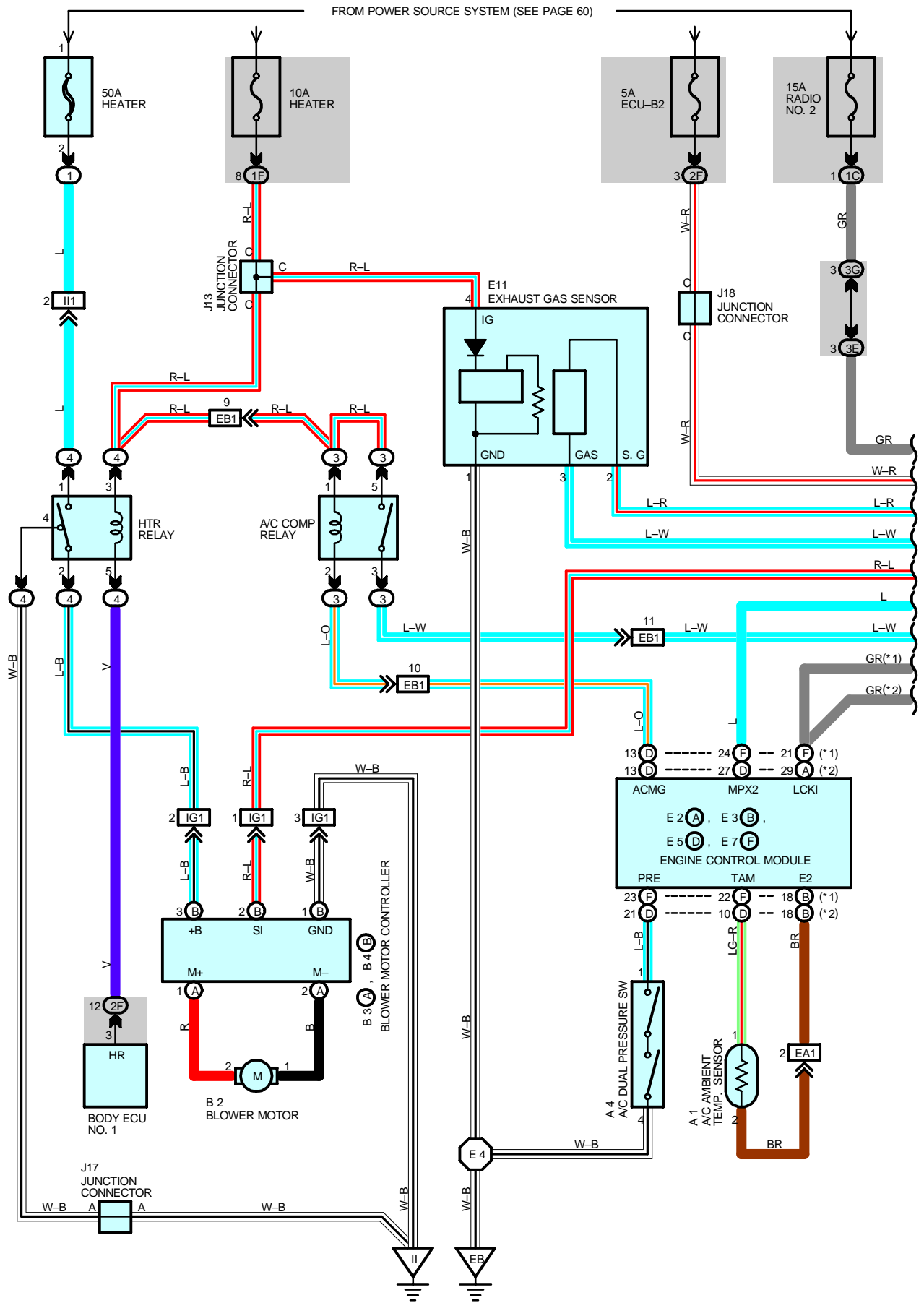

A13 (A), A14 (B)
A/C CONTROL ASSEMBLY

* 1 : 1UZ-FE
* 2 : 2JZ-GE

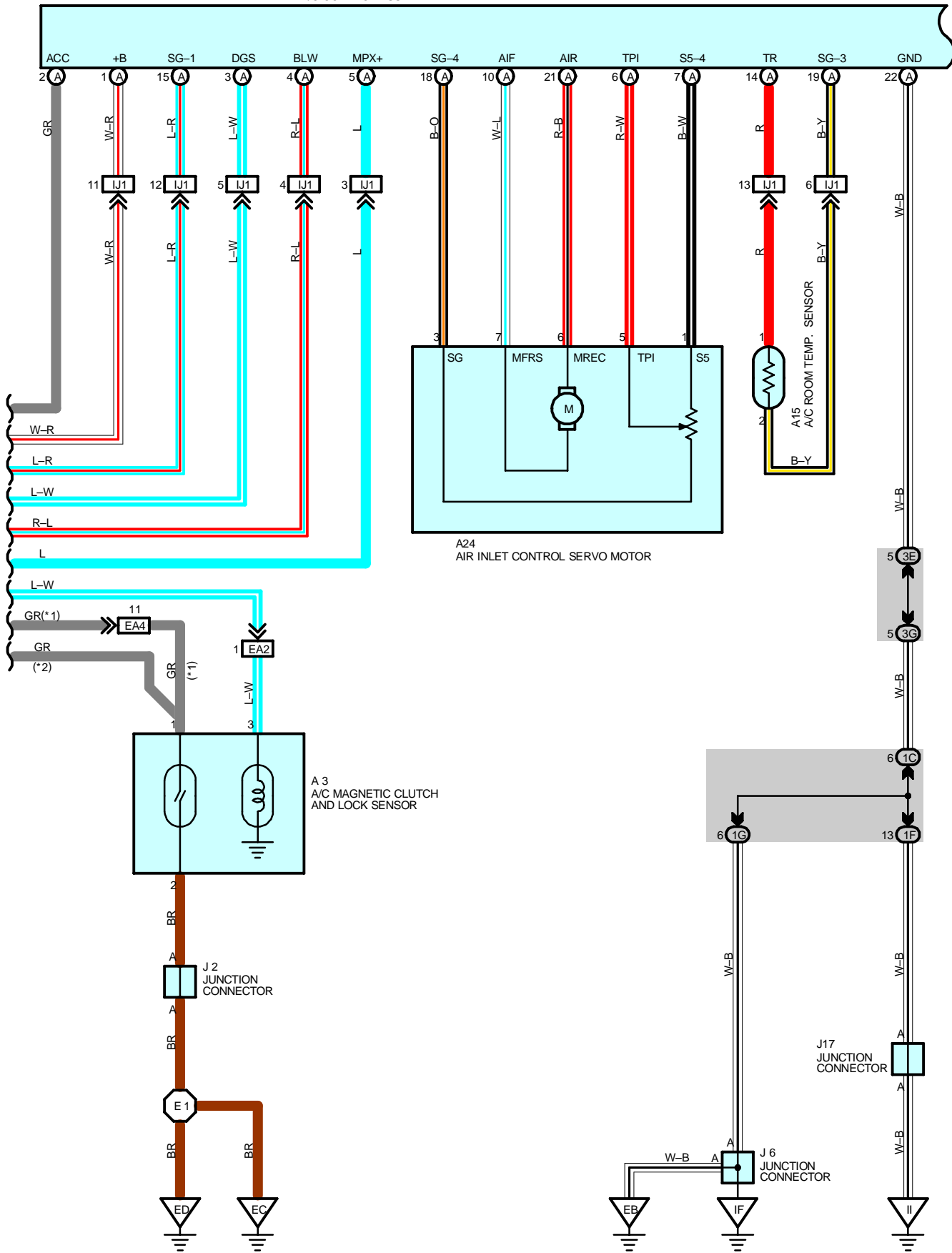

AUTOMATIC AIR CONDITIONING

A13 (A), A14 (B)
A/C CONTROL ASSEMBLY

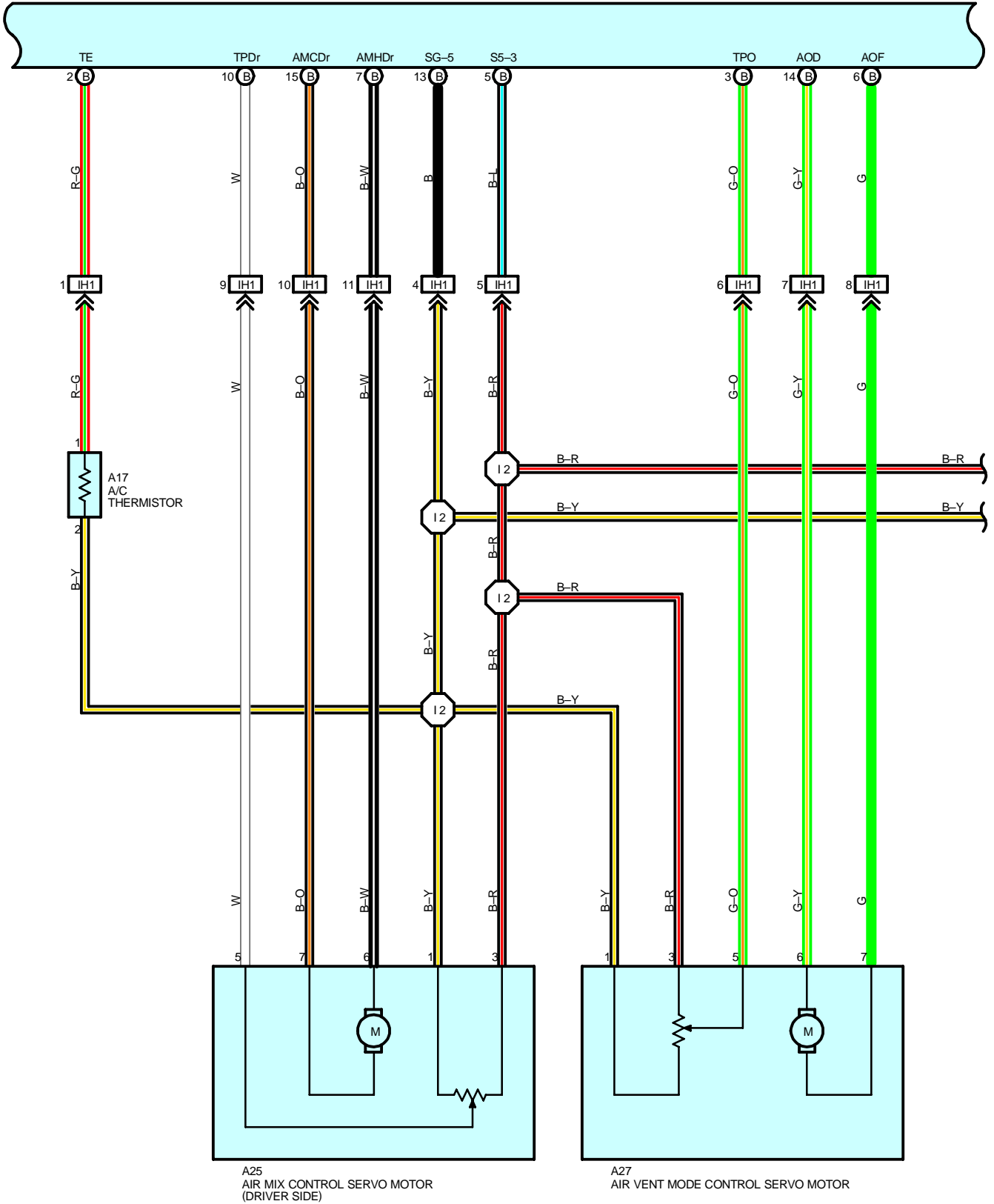

A13 (A), A14 (B)
A/C CONTROL ASSEMBLY

* 3 : W/ LEXUS NAVIGATION SYSTEM
* 4 : W/O LEXUS NAVIGATION SYSTEM

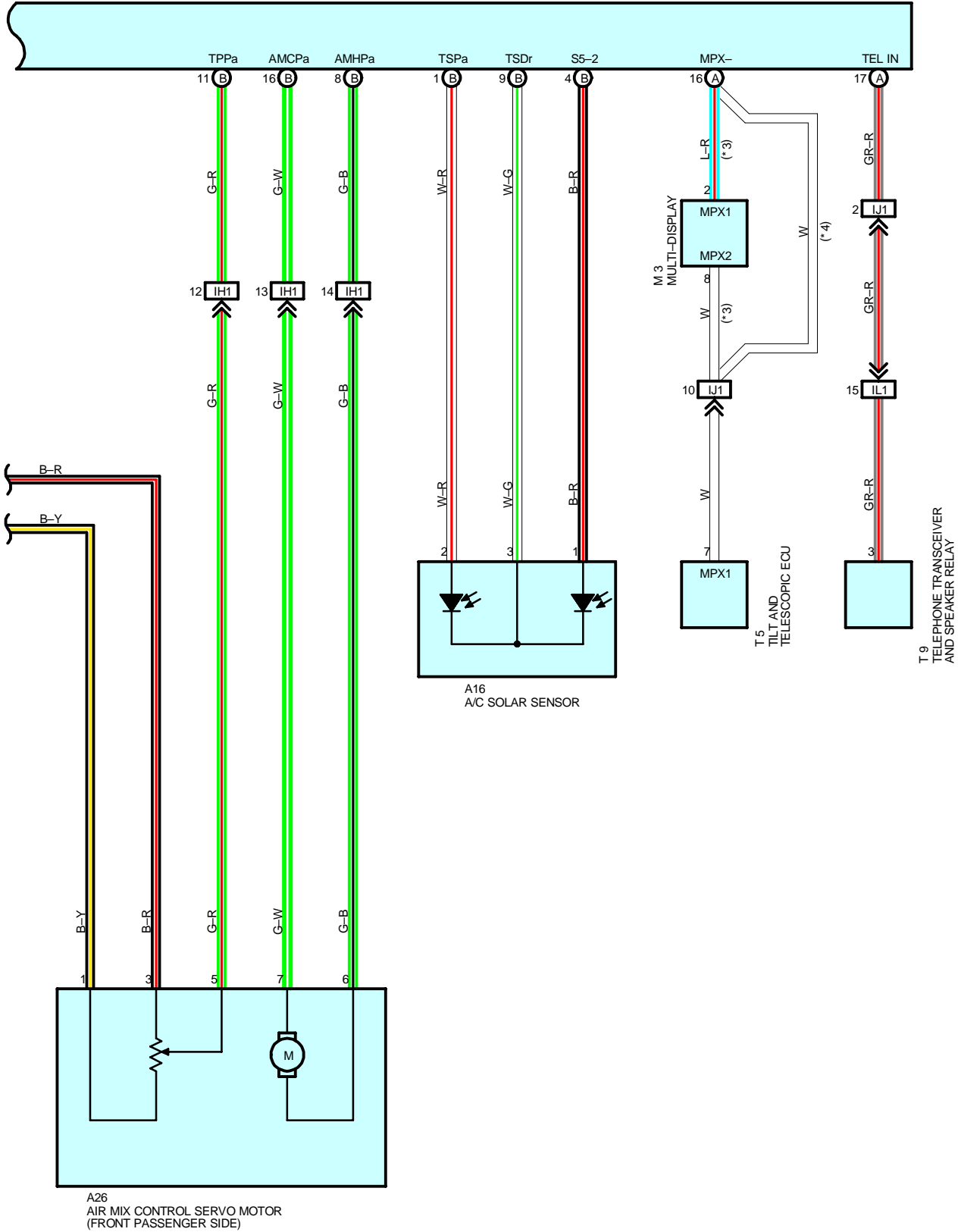

AUTOMATIC AIR CONDITIONING

SYSTEM OUTLINE

1. HEATER BLOWER OPERATION

Manual operation

When the blower speed is set to a certain level using the blower control SW, the A/C control assembly sends the signals to the blower control to control the blower motor speed.

Auto operation

When the auto SW is turned on, the A/C control assembly sends the signals from various sensors and temperature SW to the blower control to automatically control the blower motor speed.

2. AIR INLET CONTROL SERVO MOTOR CONTROL

When the FRESH/RECIRC select SW is set to RECIRC, the motor in the air inlet control servo motor starts rotating to move the damper toward the RECIRC side. Since the damper position is detected by the TERMINAL TP1 of the A/C control assembly, the motor is continuously rotated until the damper reaches its stop position. When the FRESH/RECIRC select SW is set to FRESH, the motor in the air inlet control servo motor starts rotating to move the damper toward the FRESH side. Since the damper position is detected by the TERMINAL TP1 of the A/C control assembly, the motor is continuously rotated until the damper reaches its stop position. When the FRESH/RECIRC select SW is set to AUTO, the exhaust gas sensor installed in the engine room monitors contents in the exhaust gas and FRESH or RECIRC is automatically switched.

3. AIR VENT MODE CONTROL SERVO MOTOR CONTROL

When the mode select SW is pushed, the ECU in the A/C control assembly activates the air vent mode control servo motor. This causes the servo motor to rotate to the position (FACE, BI-LEVEL, FOOT, FOOT/DEF, DEF) selected using the mode select SW, and moves the film damper.

4. AIR MIX CONTROL SERVO MOTOR CONTROL

When the temperature control SW on the driver's side is pressed, the ECU in the A/C control assembly sends a signal to the air mix control servo motor on the driver's side. This signal drives the motor to reach the temperature set by the temperature control SW on the driver's side, and moves the film damper. Passenger's side is operated as same as the driver's side.

5. AIR CONDITIONING OPERATION

The A/C control assembly receives various signals, I.E., the engine RPM from the crankshaft position sensor, outlet temperature signal from the A/C ambient temp. sensor, coolant temperature from the engine coolant temp. sensor and the lock signal from the A/C compressor, etc. When the engine is started and the A/C SW is on, a signal is input to the ECU (Built into the A/C control assembly). As a result, the ground circuit in A/C control assembly is closed and current flows from HEATER fuse to TERMINAL 1 of the A/C COMP relay to TERMINAL 2 to TERMINAL ACMG of the engine control module to TERMINAL MPX2 to TERMINAL MPX+ of the A/C control assembly to TERMINAL GND to GROUND, turning the relay on so that the A/C magnetic clutch is on and the A/C compressor operates. At the same time, the engine control module detects the magnetic clutch is on and the A/C compressor operates and rotates the motor to the open direction to avoid lowering the engine RPM during A/C operation. When any of the following signals are input to the A/C control assembly, the control assembly operates to turn off the air conditioning.

- * Coolant temp. signal is high.
- * A signal that the temperature at the air outlet is low.
- * A signal that there is a large difference between engine speed and compressor speed.
- * A signal that the refrigerant pressure is abnormally high or low.

SERVICE HINTS

A4 A/C DUAL PRESSURE SW

1-4 : Open with the refrigerant pressure at less than approx. **216 kpa (2.2 kgf/cm², 31 psi)** or more than approx. **3138 kpa (32 kgf/cm², 455 psi)**

A13 (A) A/C CONTROL ASSEMBLY

- +B-GROUND : Always approx. **12 volts**
- ACC-GROUND : Approx. **12 volts** with ignition SW at **ACC** or **ON** position
- AIF-GROUND : Approx. **12 volts** with FRESH SW on
- AIR-GROUND : Approx. **12 volts** with RECIRC SW on
- GND-GROUND : Always continuity

○ : PARTS LOCATION

Code		See Page	Code		See Page	Code		See Page
A1		36 (1UZ-FE)	A25		40	E11	36 (1UZ-FE)	
		38 (2JZ-GE)	A26		40		38 (2JZ-GE)	
A3		36 (1UZ-FE)	A27		40	J2	37 (1UZ-FE)	
		38 (2JZ-GE)	B2		40		39 (2JZ-GE)	
A4		36 (1UZ-FE)	B3	A	40	J6	41	
		38 (2JZ-GE)	B4	B	40	J13	41	
A13	A	40	E2	A	38 (2JZ-GE)	J17	41	
A14	B	40	E3	B	36 (1UZ-FE)	J18	41	
A15		40			38 (2JZ-GE)	M3	41	
A16		40	E5	D	36 (1UZ-FE)	T5	41	
A17		40			38 (2JZ-GE)	T9	43	
A24		40	E7	F	36 (1UZ-FE)			

○ : RELAY BLOCKS

Code	See Page	Relay Blocks (Relay Block Location)
1	22	Engine Room No.1 R/B (Engine Compartment Right)
3	24	Engine Room No.3 R/B (Engine Compartment Left)
4	25	Passenger Side R/B (Right Kick Panel)

○ : JUNCTION BLOCK AND WIRE HARNESS CONNECTOR

Code	See Page	Junction Block and Wire Harness (Connector Location)
1C	26	Instrument Panel Wire and Driver Side J/B (Left Kick Panel)
1F	26	Cowl Wire and Driver Side J/B (Left Kick Panel)
1G	27	
2F	28	Cowl Wire and Passenger Side J/B (Right Kick Panel)
3E	31	Instrument Panel Wire and Instrument Panel J/B (Instrument Panel Reinforcement Center)
3G		

□ : CONNECTOR JOINING WIRE HARNESS AND WIRE HARNESS

Code	See Page	Joining Wire Harness and Wire Harness (Connector Location)
EA1	46 (1UZ-FE)	Engine Wire and Cowl Wire (Inside of the ECU Box)
	48 (2JZ-GE)	
EA2	46 (1UZ-FE)	
	48 (2JZ-GE)	
EA4	46 (1UZ-FE)	
	48 (2JZ-GE)	
EB1	46 (1UZ-FE)	Cowl Wire and Relay Block Wire (Inside of the Engine Room No.3 R/B)
	48 (2JZ-GE)	
IG1	50	Cowl Wire and Blower Sub Wire (Left Side of the Blower Unit)
IH1	50	Instrument Panel Wire and A/C Sub Wire (Left Side of the Blower Unit)
II1	52	Engine Room Main Wire and Cowl Wire (Near the Passenger Side R/B)
IJ1	52	Instrument Panel Wire and Cowl Wire (Left Side of the Blower Unit)
IL1	52	Floor No.1 Wire and Cowl Wire (Right Kick Panel)

AUTOMATIC AIR CONDITIONING

▽ : GROUND POINTS

Code	See Page	Ground Points Location
EB	46 (1UZ-FE)	Left Fender
	48 (2JZ-GE)	
EC	46 (1UZ-FE)	RH Bank of the Cylinder Head
	48 (2JZ-GE)	Front Side of the Intake Manifold
ED	46 (1UZ-FE)	LH Bank of the Cylinder Head
	48 (2JZ-GE)	Rear Side of the Intake Manifold
IF	50	Left Kick Panel
II	50	Right Side of the Cowl Panel

○ : SPLICE POINTS

Code	See Page	Wire Harness with Splice Points	Code	See Page	Wire Harness with Splice Points
E1	46 (1UZ-FE)	Engine Wire	E4	48 (2JZ-GE)	Cowl Wire
	48 (2JZ-GE)		I2	52	A/C Sub Wire
E4	46 (1UZ-FE)	Cowl Wire			

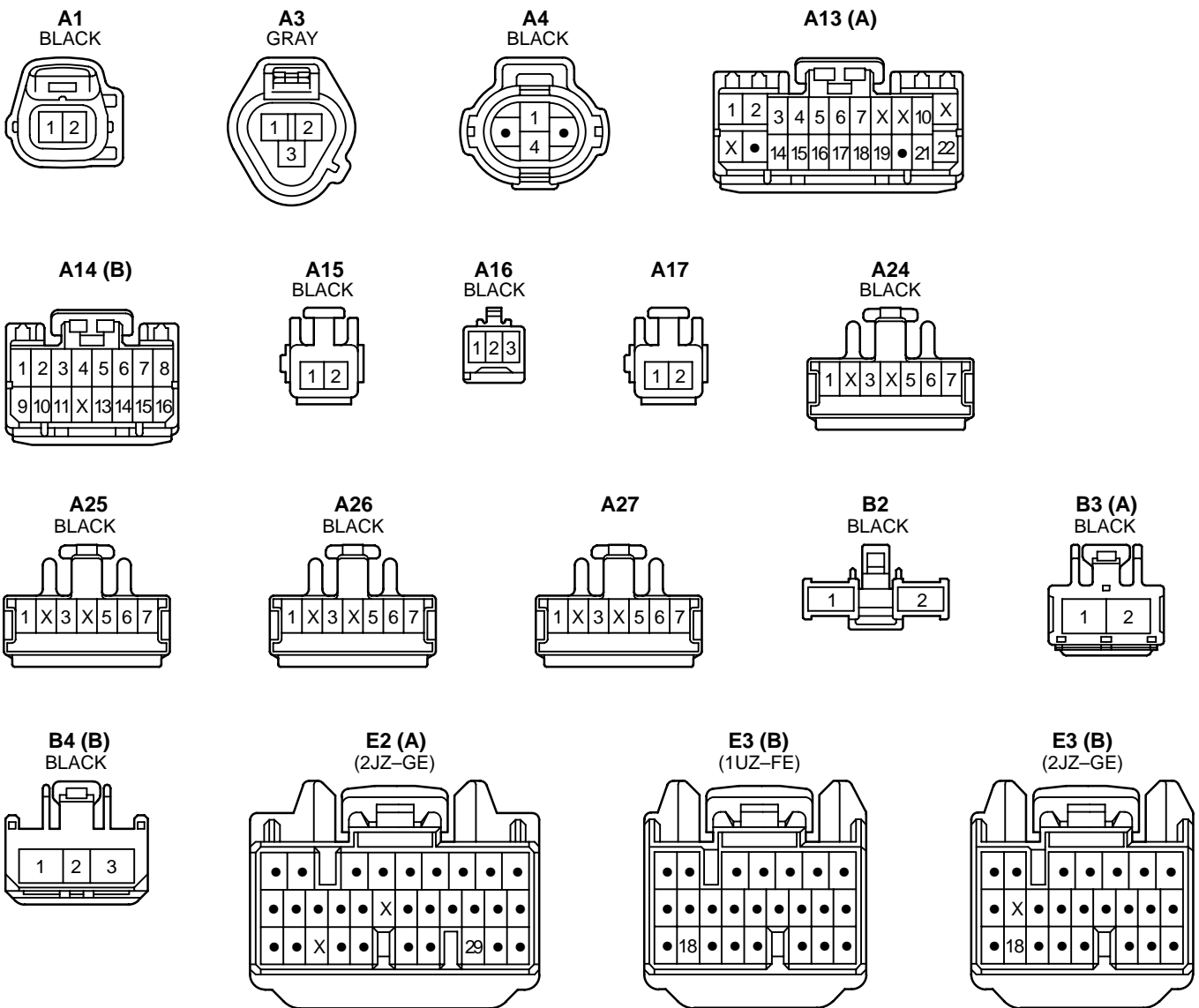

E5 (D)
(1UZ-FE)

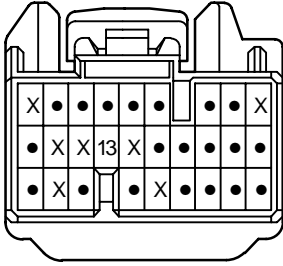

E5 (D)
(2JZ-GE)

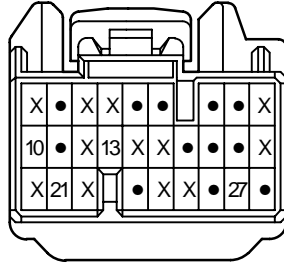

E7 (F)
(1UZ-FE)

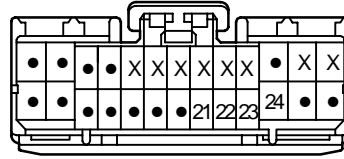

E11
BLACK



J2
ORANGE

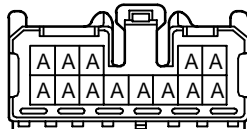

(Hint : See Page 7)

J6

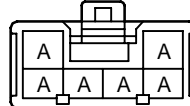

(Hint : See Page 7)

J13

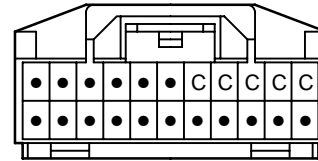

(Hint : See Page 7)

J17

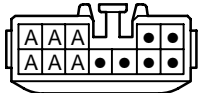

(Hint : See Page 7)

J18
BLUE

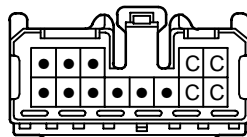

(Hint : See Page 7)

M3
BLUE

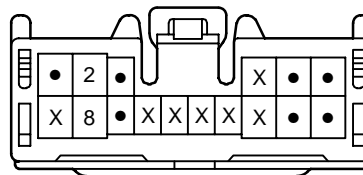

T5
GRAY

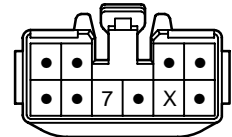

T9

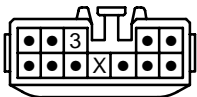

AUTOMATIC GLARE-RESISTANT EC MIRROR

FROM POWER SOURCE SYSTEM (SEE PAGE 60)

- * 1 : W/ DRIVING POSITION MEMORY
- * 2 : W/O DRIVING POSITION MEMORY

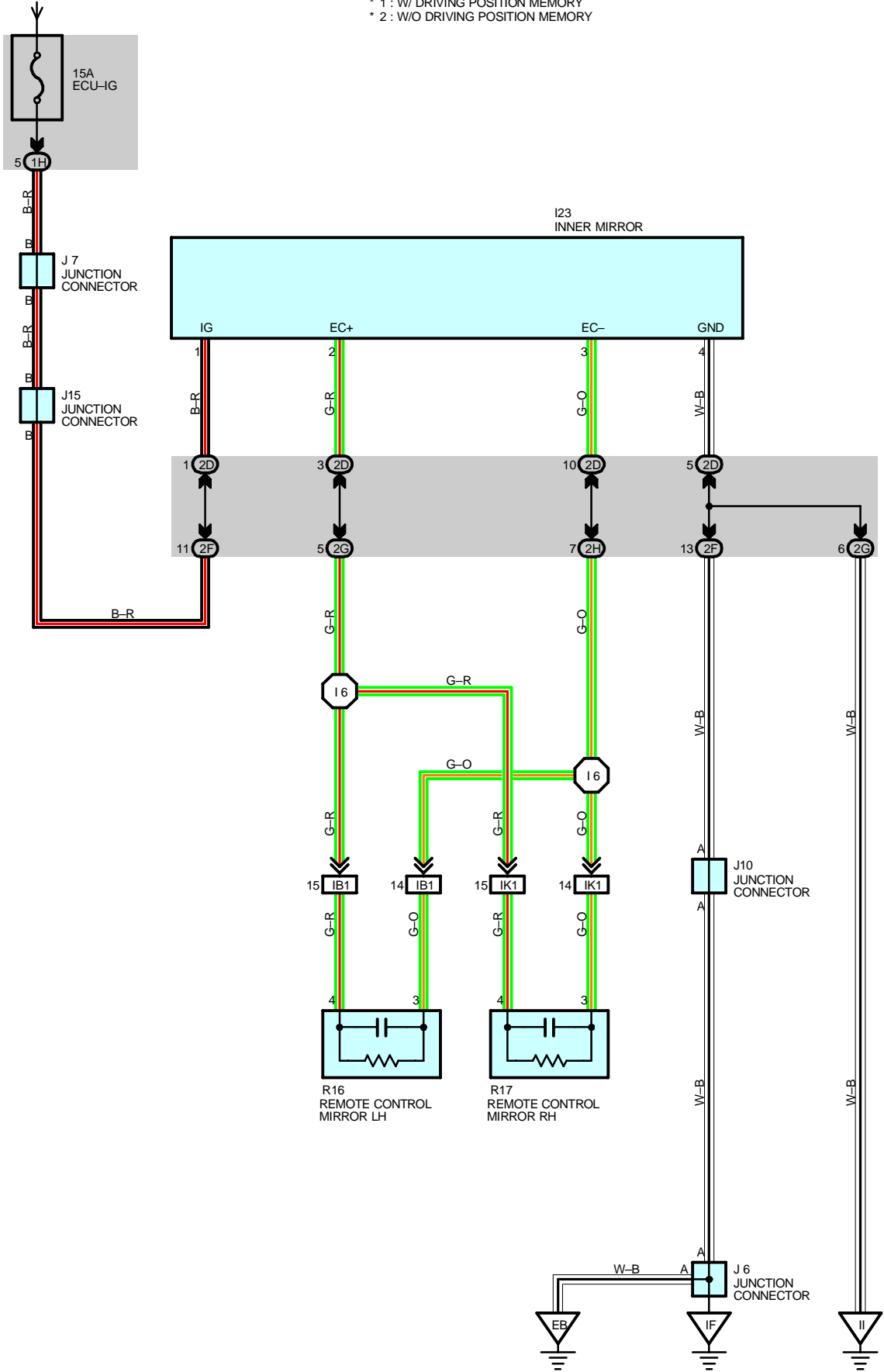

SERVICE HINTS

I23 INNER MIRROR

- 1-GROUND : Approx. 12 volts with ignition SW at **ON** or **ST** position
- 4-GROUND : Always continuity

○ : PARTS LOCATION

Code	See Page	Code	See Page	Code	See Page
I23	42	J10	41	R17	43
J6	41	J15	41		
J7	41	R16	43		

○ : JUNCTION BLOCK AND WIRE HARNESS CONNECTOR

Code	See Page	Junction Block and Wire Harness (Connector Location)
1H	27	Cowl Wire and Driver Side J/B (Left Kick Panel)
2D	28	Roof Wire and Passenger Side J/B (Right Kick Panel)
2F	28	Cowl Wire and Passenger Side J/B (Right Kick Panel)
2G	29	
2H		

□ : CONNECTOR JOINING WIRE HARNESS AND WIRE HARNESS

Code	See Page	Joining Wire Harness and Wire Harness (Connector Location)
IB1	50	Front Door LH Wire and Cowl Wire (Left Kick Panel)
IK1	52	Front Door RH Wire and Cowl Wire (Right Kick Panel)

▽ : GROUND POINTS

Code	See Page	Ground Points Location
EB	46 (1UZ-FE)	Left Fender
	48 (2JZ-GE)	
IF	50	Left Kick Panel
II	50	Right Side of the Cowl Panel

○ : SPLICE POINTS

Code	See Page	Wire Harness with Splice Points	Code	See Page	Wire Harness with Splice Points
I6	52	Cowl Wire			

I23
ORANGE

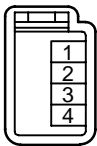

J6

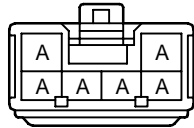

(Hint : See Page 7)

J7
GRAY

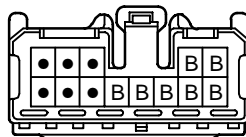

(Hint : See Page 7)

J10
ORANGE

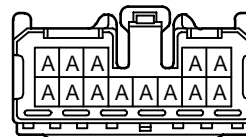

(Hint : See Page 7)

J15

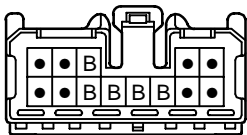

(Hint : See Page 7)

R16

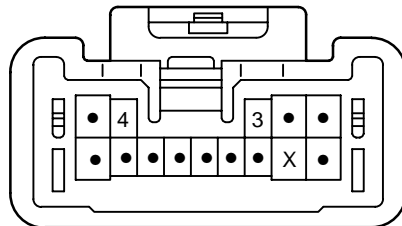

R17

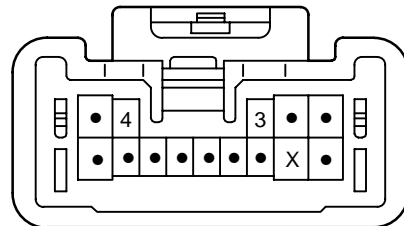

AUTOMATIC LIGHT CONTROL

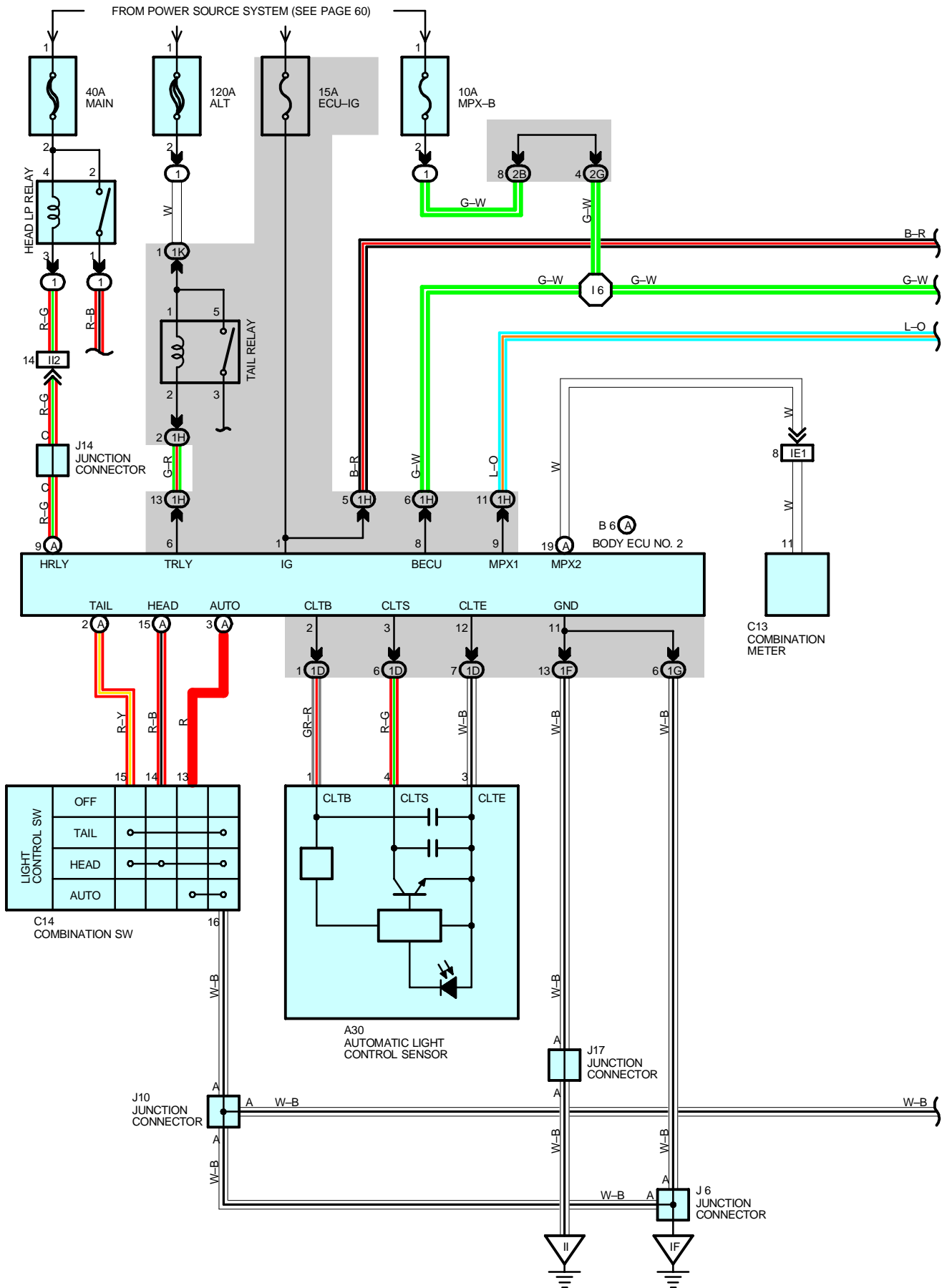

FROM POWER SOURCE SYSTEM (SEE PAGE 60)

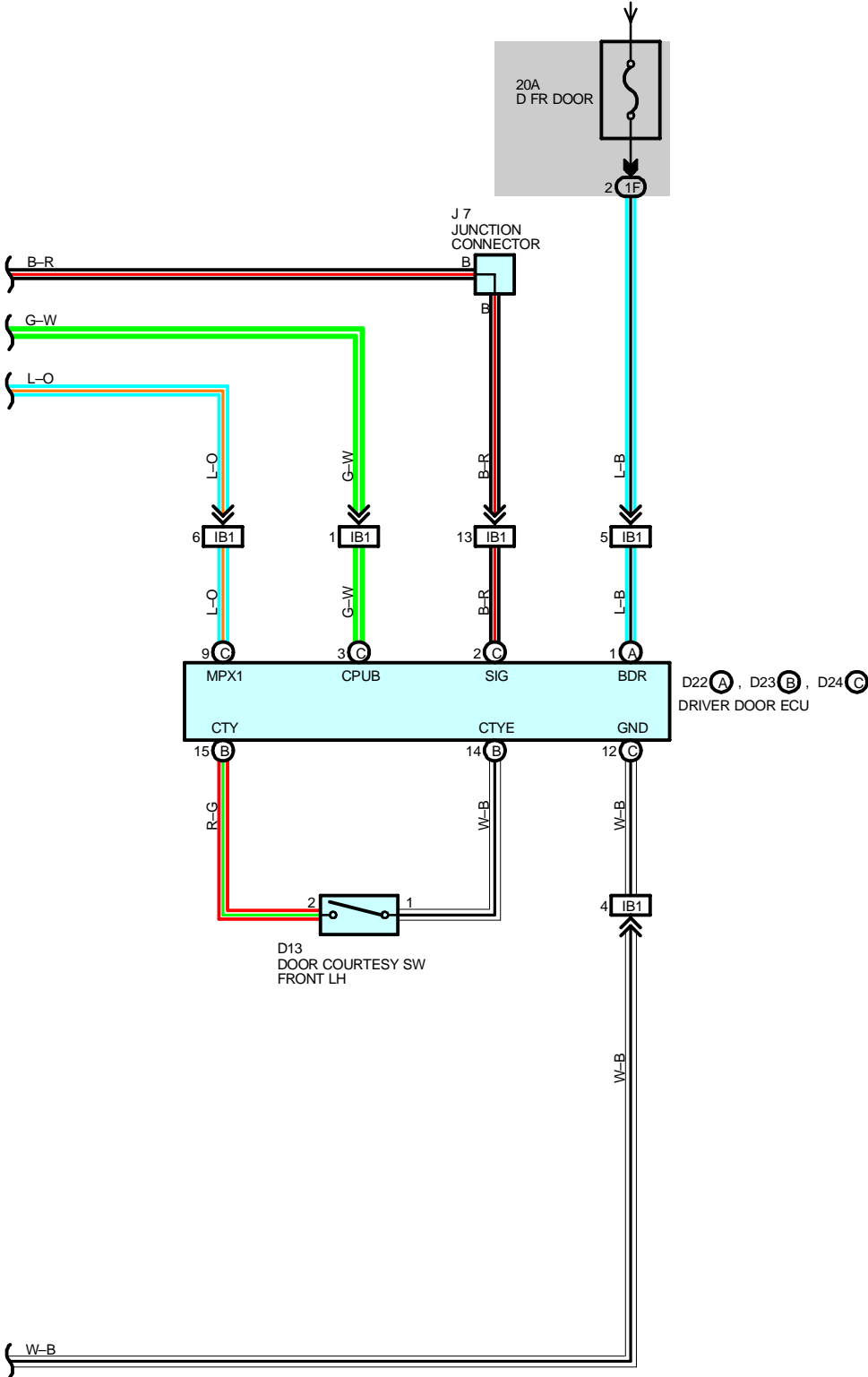

AUTOMATIC LIGHT CONTROL

SYSTEM OUTLINE

When the light control SW is set at AUTO, the automatic light control system automatically turns on or off the taillights and headlights depending on the brightness around the vehicle.

AUTOMATIC LIGHT CONTROL OPERATION

The automatic light control sensor converts the intensity of the illumination into frequency and inputs it to the body ECU No.2. When the light control SW is set at AUTO, the signal is input to TERMINAL AUTO of the body ECU No.2. Through communication control of the body ECU and door ECU etc. , the taillights and headlights are automatically turned on or off.

Turn on operation

When the body ECU No.2 receives the frequency signal from the automatic light control sensor and determines that the brightness around the vehicle has decreased below a specified level, TERMINAL TRLY and HRLY of the body ECU No.2 are controlled through communication control of the body ECU and door ECU etc. As a result, the taillights and headlights light up as the TAIL relay and HEAD LP relay are turned on.

Turn off operation

When the body ECU No.2 receives the frequency signal from the automatic light control sensor and determines that the brightness around the vehicle has exceeded a specified level, TERMINAL TRLY and HRLY of the body ECU No.2 are controlled through communication control of the body ECU and door ECU etc. As a result, the taillights and headlights go off as the TAIL relay and HEAD LP relay are turned off.

Additionally, when the ignition SW is changed from ON to OFF and any door is opened, and then closed with the taillights and headlights lit (The automatic light control is functioning), the taillights and headlights are turned off in the same manner as the light auto turn off operation.

SERVICE HINTS

C14 LIGHT CONTROL SW [COMB. SW]

- 15-16 : Closed with light control SW at **TAIL** or **HEAD** position
- 14-16 : Closed with light control SW at **HEAD** position
- 13-16 : Closed with light control SW at **AUTO** position

D13 DOOR COURTESY SW FRONT LH

- 1-2 : Closed with driver door open

○ : PARTS LOCATION

Code	See Page	Code	See Page	Code	See Page		
A30	40	D22	A	42	J10	41	
B6	A	40	D23	B	42	J14	41
C13	40	D24	C	42	J17	41	
C14	40	J6	41				
D13	42	J7	41				

○ : RELAY BLOCKS

Code	See Page	Relay Blocks (Relay Block Location)
1	22	Engine Room No.1 R/B (Engine Compartment Right)

○ : JUNCTION BLOCK AND WIRE HARNESS CONNECTOR

Code	See Page	Junction Block and Wire Harness (Connector Location)
1D	26	Instrument Panel Wire and Driver Side J/B (Left Kick Panel)
1F	26	Cowl Wire and Driver Side J/B (Left Kick Panel)
1G	27	
1H		
1K	26	
2B	28	Engine Room Main Wire and Passenger Side J/B (Right Kick Panel)
2G	29	Cowl Wire and Passenger Side J/B (Right Kick Panel)

□ : CONNECTOR JOINING WIRE HARNESS AND WIRE HARNESS

Code	See Page	Joining Wire Harness and Wire Harness (Connector Location)
IB1	50	Front Door LH Wire and Cowl Wire (Left Kick Panel)
IE1	50	Instrument Panel Wire and Cowl Wire (Left Side of the Steering Column)
II2	52	Engine Room Main Wire and Cowl Wire (Near the Passenger Side R/B)

▽ : GROUND POINTS

Code	See Page	Ground Points Location
IF	50	Left Kick Panel
II	50	Right Side of the Cowl Panel

○ : SPLICE POINTS

Code	See Page	Wire Harness with Splice Points	Code	See Page	Wire Harness with Splice Points
I6	52	Cowl Wire			

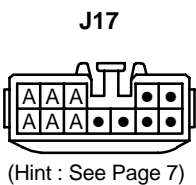
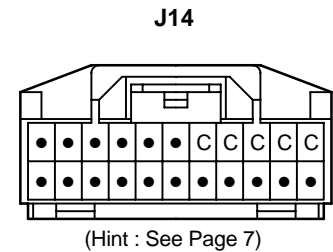
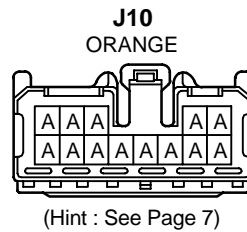
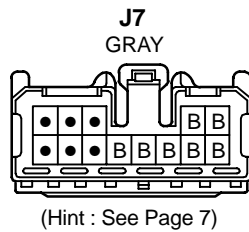
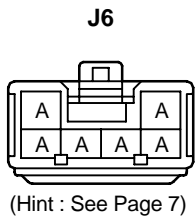
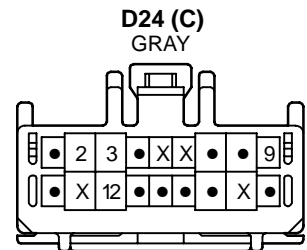
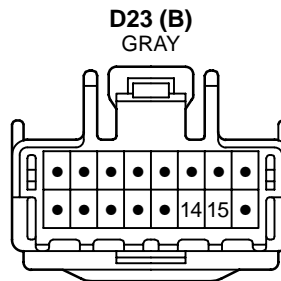
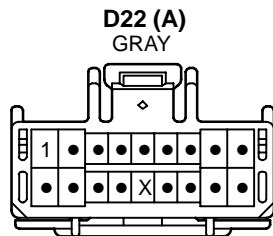
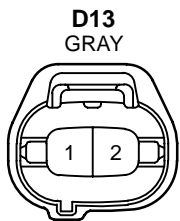
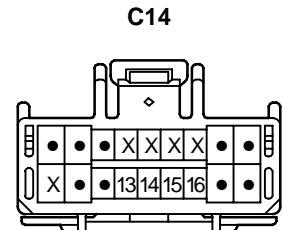
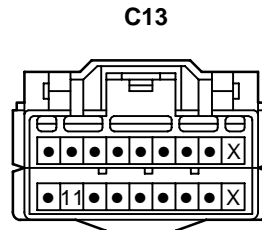
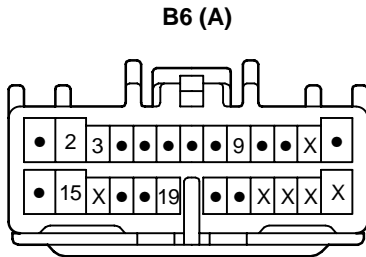
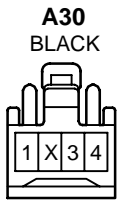

BACK-UP LIGHT

FROM POWER SOURCE SYSTEM (SEE PAGE 60)

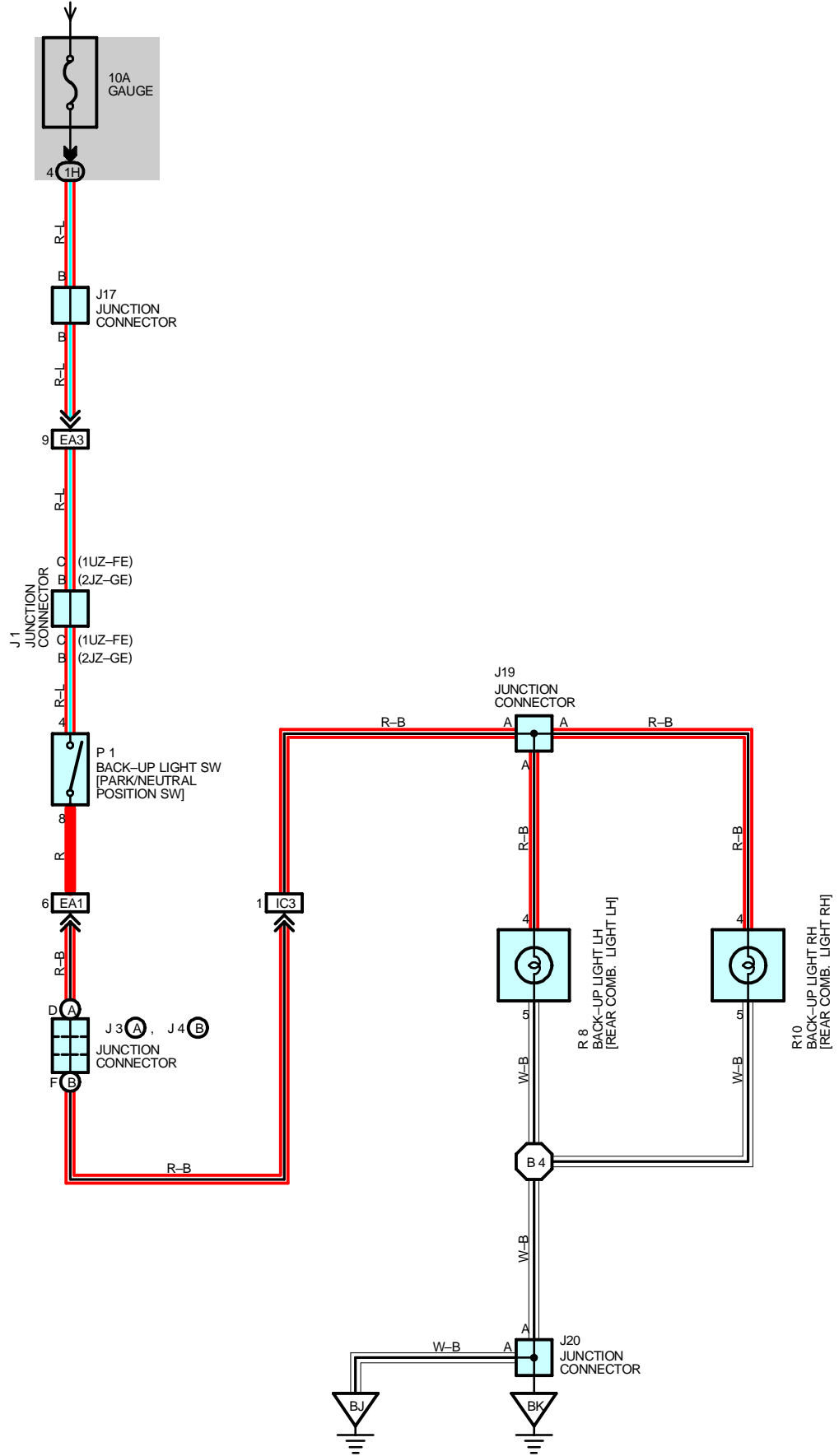

SERVICE HINTS

P1 BACK-UP LIGHT SW [PARK/NEUTRAL POSITION SW]

4-8 : Closed with shift lever in R position

○ : PARTS LOCATION

Code	See Page	Code	See Page	Code	See Page
J1	37 (1UZ-FE)	J4	B	39 (2JZ-GE)	P1
	39 (2JZ-GE)	J17		41	R8
J3	A	37 (1UZ-FE)	J19	42	R10
		39 (2JZ-GE)	J20	42	
J4	B	37 (1UZ-FE)	P1	37 (1UZ-FE)	

○ : JUNCTION BLOCK AND WIRE HARNESS CONNECTOR

Code	See Page	Junction Block and Wire Harness (Connector Location)
1H	27	Cowl Wire and Driver Side J/B (Left Kick Panel)

□ : CONNECTOR JOINING WIRE HARNESS AND WIRE HARNESS

Code	See Page	Joining Wire Harness and Wire Harness (Connector Location)
EA1	46 (1UZ-FE)	Engine Wire and Cowl Wire (Inside of the ECU Box)
	48 (2JZ-GE)	
EA3	46 (1UZ-FE)	
	48 (2JZ-GE)	
IC3	50	Floor No.2 Wire and Cowl Wire (Left Kick Panel)

▽ : GROUND POINTS

Code	See Page	Ground Points Location
BJ	54	Rear Floor Partition Panel LH
BK	54	Quarter Panel LH

○ : SPLICE POINTS

Code	See Page	Wire Harness with Splice Points	Code	See Page	Wire Harness with Splice Points
B4	54	Floor No.2 Wire			

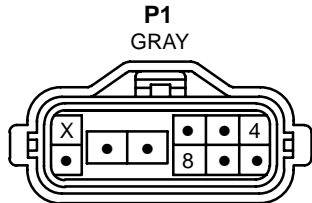
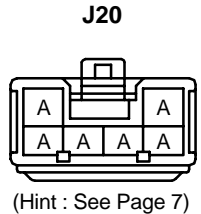
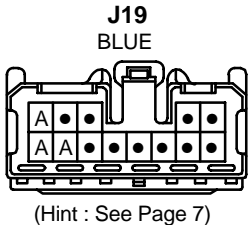
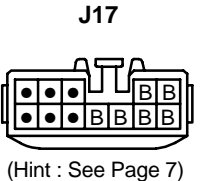
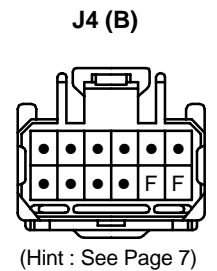
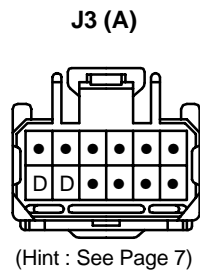
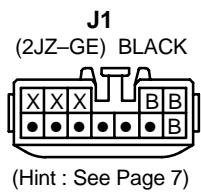
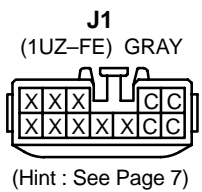

BACK-UP LIGHT

R8

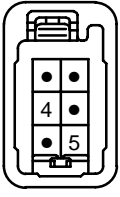

R10

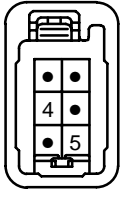

CELLULAR MOBILE TELEPHONE

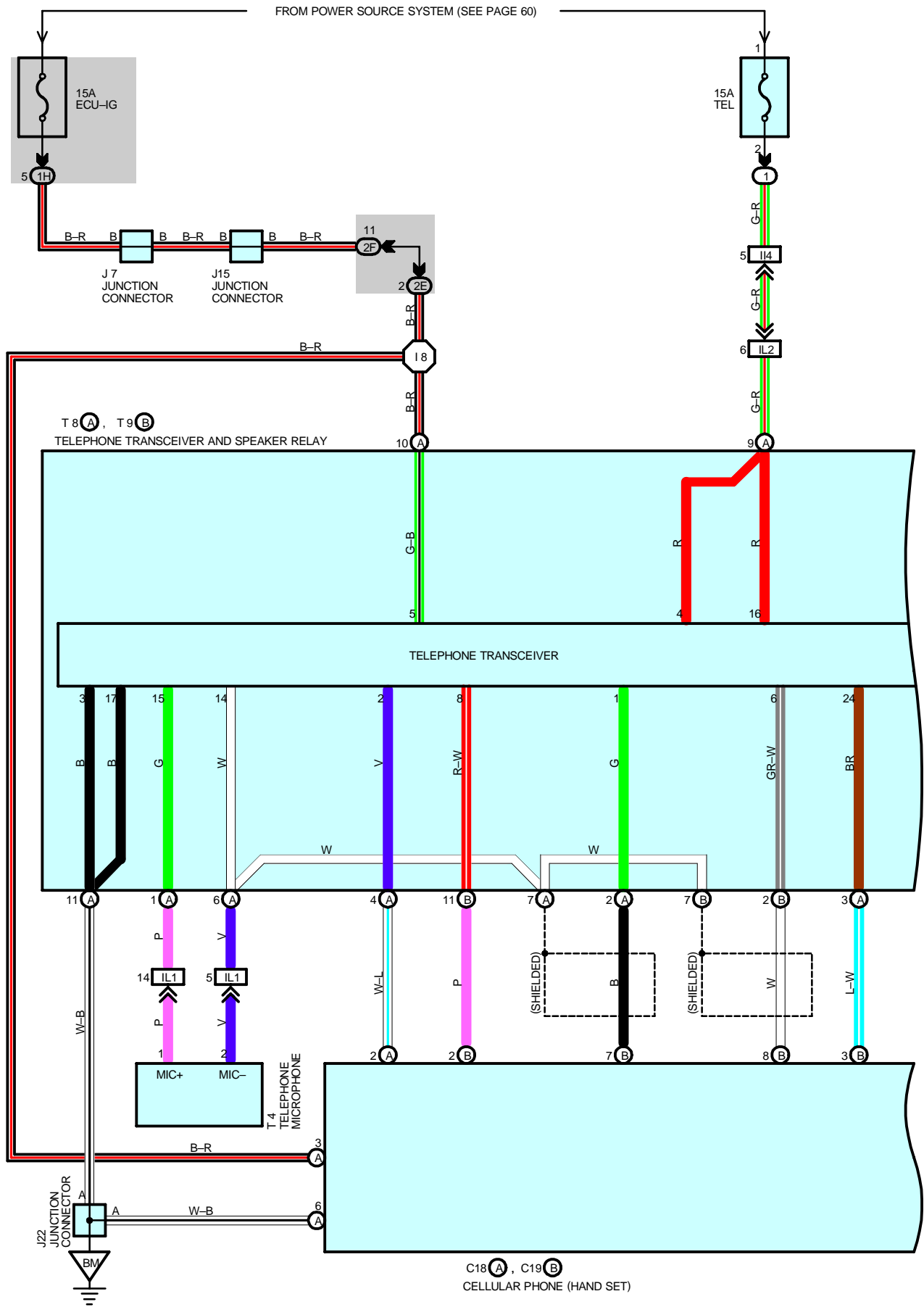

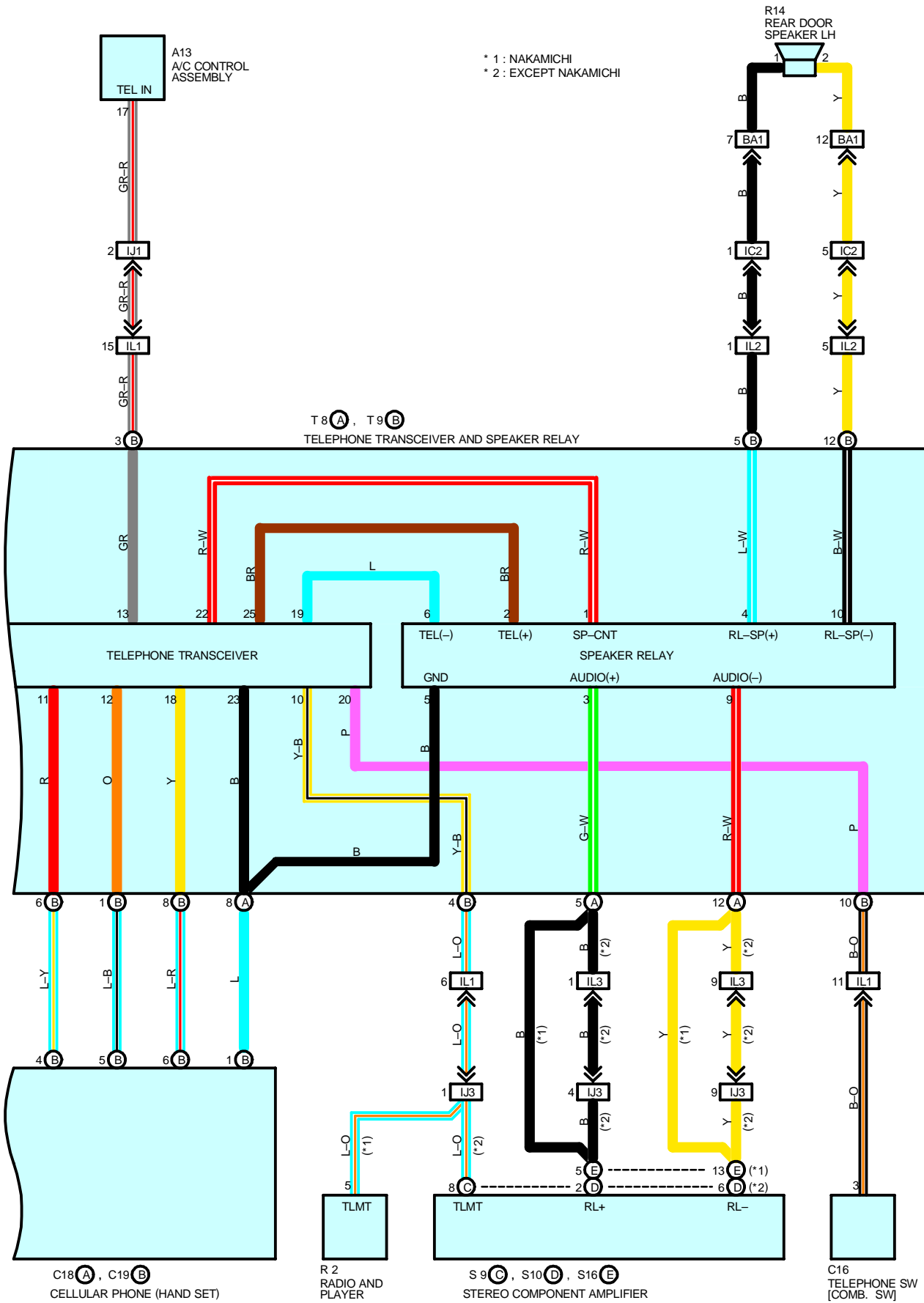

CELLULAR MOBILE TELEPHONE

SERVICE HINTS

T8 (A) TELEPHONE TRANSCEIVER AND SPEAKER RELAY

(A) 9-GROUND : Always approx. 12 volts

(A)10-GROUND : Approx. 12 volts with ignition SW at **ON** or **ST** position

(A)11-GROUND : Always continuity

○ : PARTS LOCATION

Code	See Page	Code	See Page	Code	See Page
A13	40	J15	41	S10	D 41
C16	40	J22	42	S16	E 43
C18	A 42	R2	41	T4	41
C19	B 42	R14	43	T8	A 43
J7	41	S9	C 41	T9	B 43

○ : RELAY BLOCKS

Code	See Page	Relay Blocks (Relay Block Location)
1	22	Engine Room No.1 R/B (Engine Compartment Right)

○ : JUNCTION BLOCK AND WIRE HARNESS CONNECTOR

Code	See Page	Junction Block and Wire Harness (Connector Location)
1H	27	Cowl Wire and Driver Side J/B (Left Kick Panel)
2E	28	Floor No.1 Wire and Passenger Side J/B (Right Kick Panel)
2F	28	Cowl Wire and Passenger Side J/B (Right Kick Panel)

□ : CONNECTOR JOINING WIRE HARNESS AND WIRE HARNESS

Code	See Page	Joining Wire Harness and Wire Harness (Connector Location)
IC2	50	Floor No.2 Wire and Cowl Wire (Left Kick Panel)
II4	52	Engine Room Main Wire and Cowl Wire (Near the Passenger Side R/B)
IJ1	52	Instrument Panel Wire and Cowl Wire (Left Side of the Blower Unit)
IJ3		
IL1	52	Floor No.1 Wire and Cowl Wire (Right Kick Panel)
IL2		
IL3		
BA1	54	Rear Door LH Wire and Floor No.2 Wire (Under the Center Pillar LH)

▽ : GROUND POINTS

Code	See Page	Ground Points Location
BM	54	Quarter Panel RH

○ : SPLICE POINTS

Code	See Page	Wire Harness with Splice Points	Code	See Page	Wire Harness with Splice Points
I8	52	Floor No.1 Wire			

A13

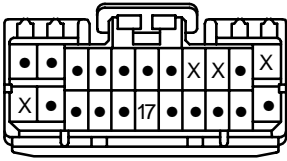

C16
(1UZ-FE) BLACK

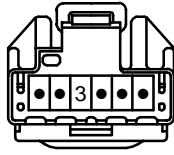

C16
(2JZ-GE) BLACK

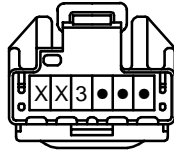

C18 (A)

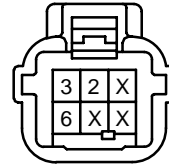

C19 (B)



J7
GRAY

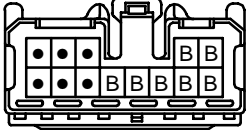

(Hint : See Page 7)

J15

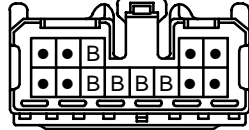

(Hint : See Page 7)

J22

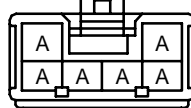

(Hint : See Page 7)

R2
(NAKAMICHI)

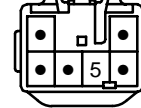

R14



S9 (C)
(Except NAKAMICHI)

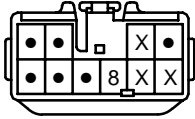

S10 (D)
(Except NAKAMICHI)

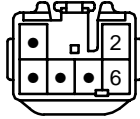

S16 (E)
(NAKAMICHI) GREEN

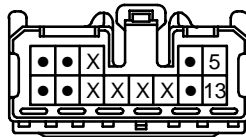

T4



T8 (A)

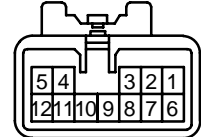

T9 (B)

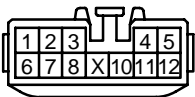

CHARGING

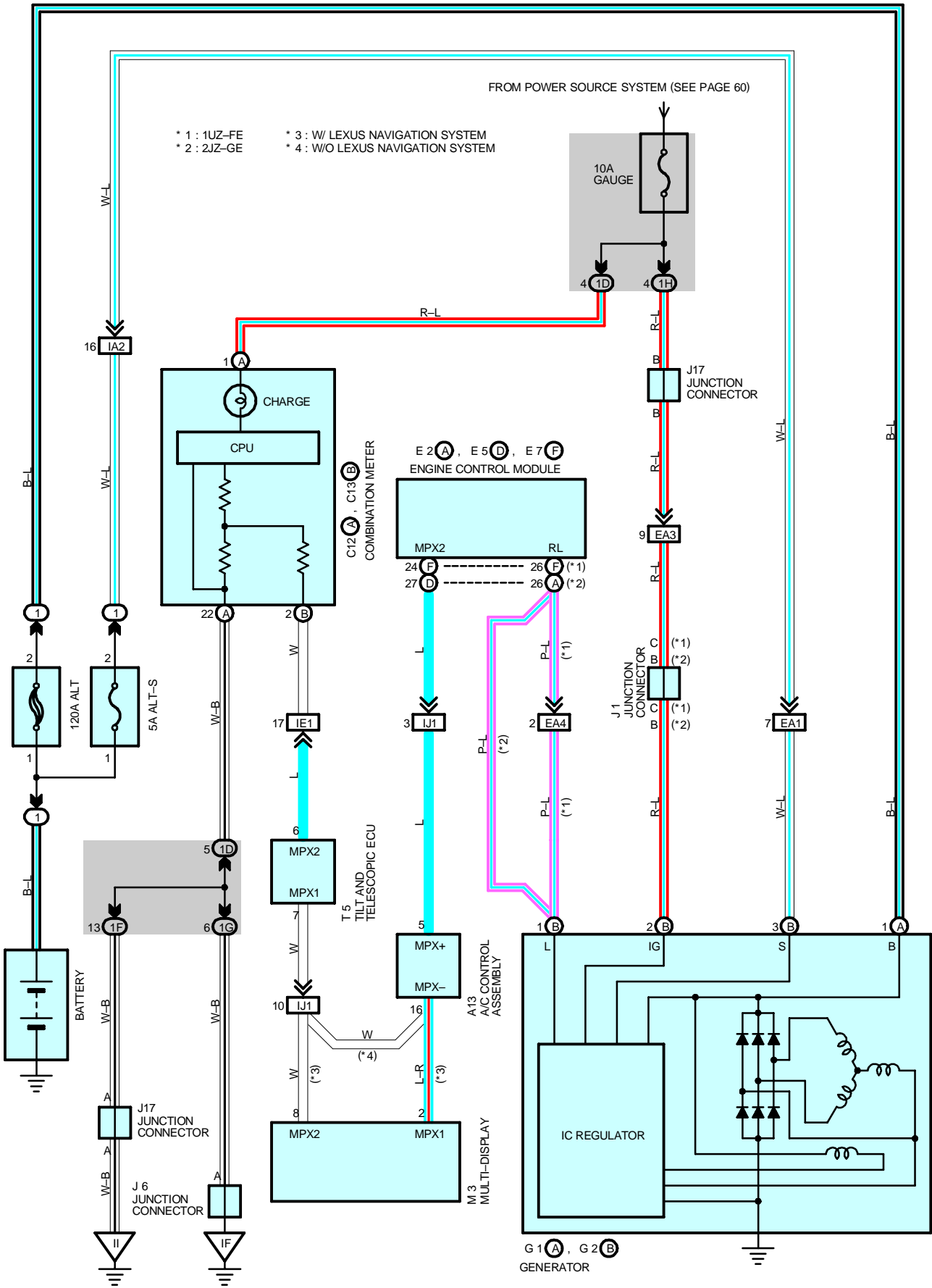

SERVICE HINTS

G1 (A), G2 (B) GENERATOR

- (A) 1-GROUND : 13.9–15.1 volts with engine running at 2000 rpm and 25°C (77°F)
 13.5–14.3 volts with engine running at 5000 rpm and 115°C (239°F)
- (B) 3-GROUND : 0–4 volts with ignition SW at ON position and engine not running

○ : PARTS LOCATION

Code		See Page	Code		See Page	Code		See Page
A13		40	G1	A	36 (1UZ-FE)		J6	41
C12	A	40			38 (2JZ-GE)		J17	41
C13	B	40	G2	B	36 (1UZ-FE)		M3	41
E2	A	38 (2JZ-GE)			38 (2JZ-GE)		T5	41
E5	D	38 (2JZ-GE)	J1		37 (1UZ-FE)			
E7	F	36 (1UZ-FE)			39 (2JZ-GE)			

○ : RELAY BLOCKS

Code	See Page	Relay Blocks (Relay Block Location)
1	22	Engine Room No.1 R/B (Engine Compartment Right)

○ : JUNCTION BLOCK AND WIRE HARNESS CONNECTOR

Code	See Page	Junction Block and Wire Harness (Connector Location)	
1D	26	Instrument Panel Wire and Driver Side J/B (Left Kick Panel)	
1F	26		
1G	27		Cowl Wire and Driver Side J/B (Left Kick Panel)
1H			

□ : CONNECTOR JOINING WIRE HARNESS AND WIRE HARNESS

Code	See Page	Joining Wire Harness and Wire Harness (Connector Location)
EA1	46 (1UZ-FE)	Engine Wire and Cowl Wire (Inside of the ECU Box)
	48 (2JZ-GE)	
EA3	46 (1UZ-FE)	
	48 (2JZ-GE)	
EA4	46 (1UZ-FE)	
IA2	50	
IE1	50	Instrument Panel Wire and Cowl Wire (Left Side of the Steering Column)
IJ1	52	Instrument Panel Wire and Cowl Wire (Left Side of the Blower Unit)

▽ : GROUND POINTS

Code	See Page	Ground Points Location
IF	50	Left Kick Panel
II	50	Right Side of the Cowl Panel

A13

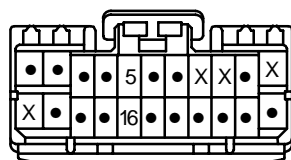

C12 (A)

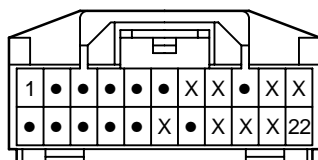

C13 (B)

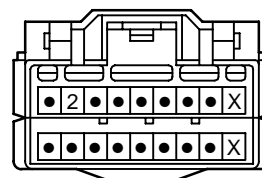

CHARGING

E2 (A)
(2JZ-GE)

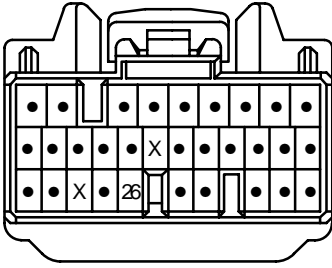

E5 (D)
(2JZ-GE)

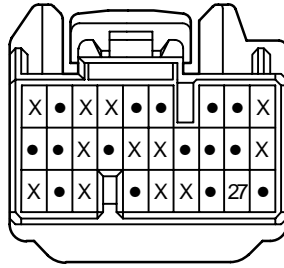

E7 (F)
(1UZ-FE)

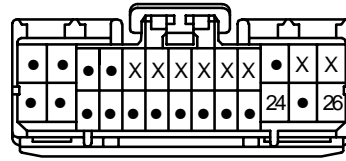

G1 (A)

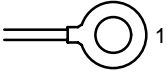

G2 (B)
BLACK

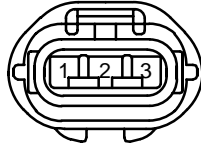

J1
(1UZ-FE) GRAY



(Hint : See Page 7)

J1
(2JZ-GE) BLACK

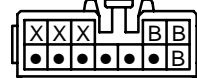

(Hint : See Page 7)

J6

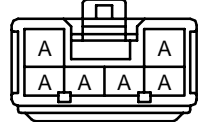

(Hint : See Page 7)

J17



(Hint : See Page 7)

M3
BLUE

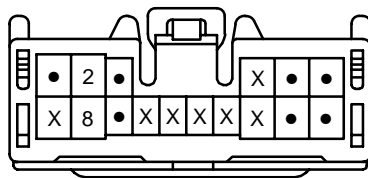

T5
GRAY

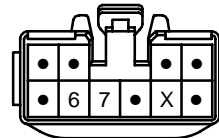

CIGARETTE LIGHTER AND POWER OUTLET

FROM POWER SOURCE SYSTEM (SEE PAGE 60)

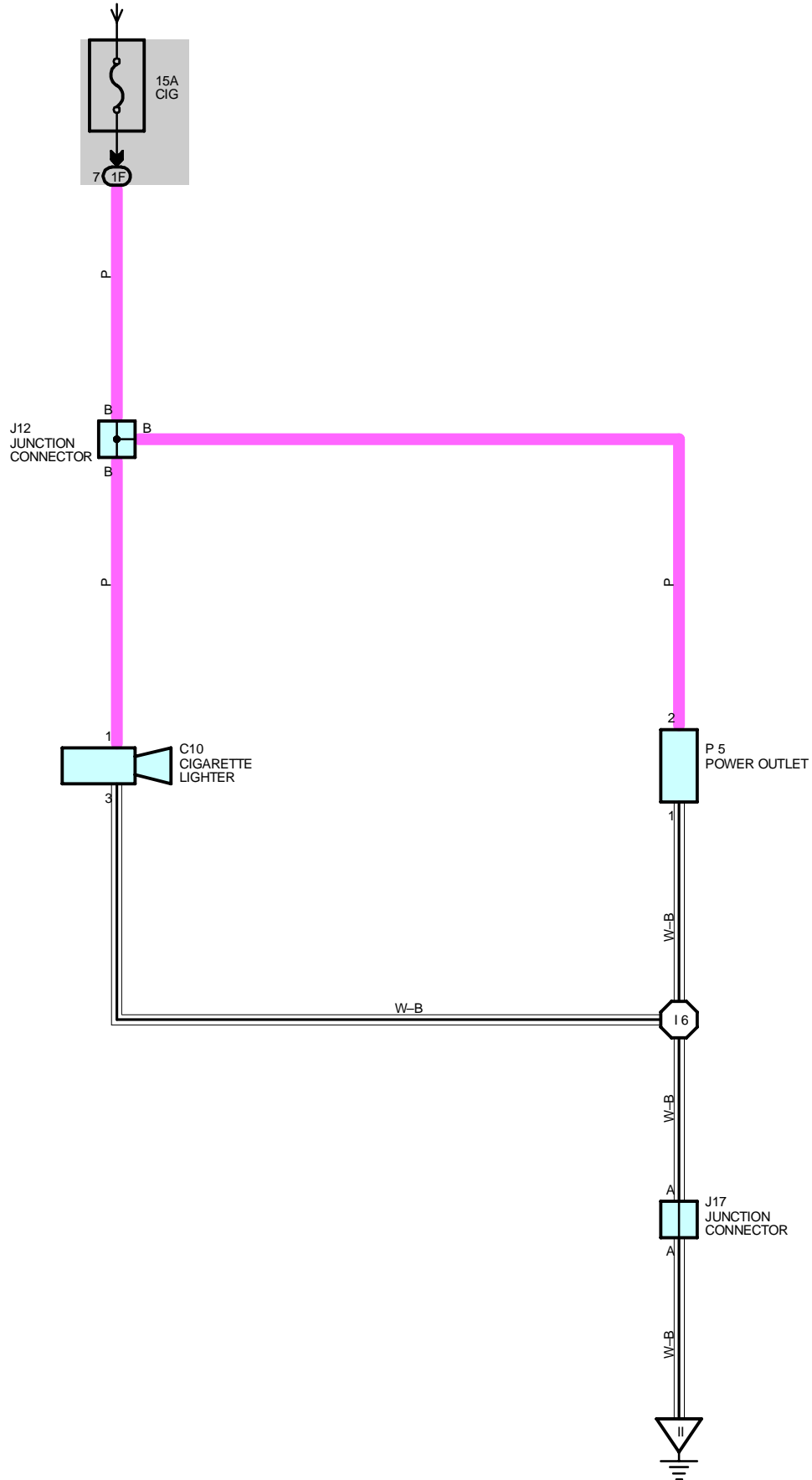

SERVICE HINTS

C10 CIGARETTE LIGHTER

- 1-GROUND : Approx. **12** volts with ignition SW at **ACC** or **ON** position
- 3-GROUND : Always continuity

P5 POWER OUTLET

- 2-GROUND : Approx. **12** volts with ignition SW at **ACC** or **ON** position
- 1-GROUND : Always continuity

○ : PARTS LOCATION

Code	See Page	Code	See Page	Code	See Page
C10	40	J17	41		
J12	41	P5	41		

○ : JUNCTION BLOCK AND WIRE HARNESS CONNECTOR

Code	See Page	Junction Block and Wire Harness (Connector Location)
1F	26	Cowl Wire and Driver Side J/B (Left Kick Panel)

▽ : GROUND POINTS

Code	See Page	Ground Points Location
II	50	Right Side of the Cowl Panel

○ : SPLICE POINTS

Code	See Page	Wire Harness with Splice Points	Code	See Page	Wire Harness with Splice Points
I6	52	Cowl Wire			

C10
BLACK

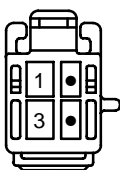

J12
GRAY

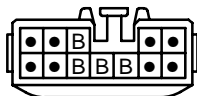

(Hint : See Page 7)

J17

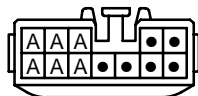

(Hint : See Page 7)

P5



CLOCK

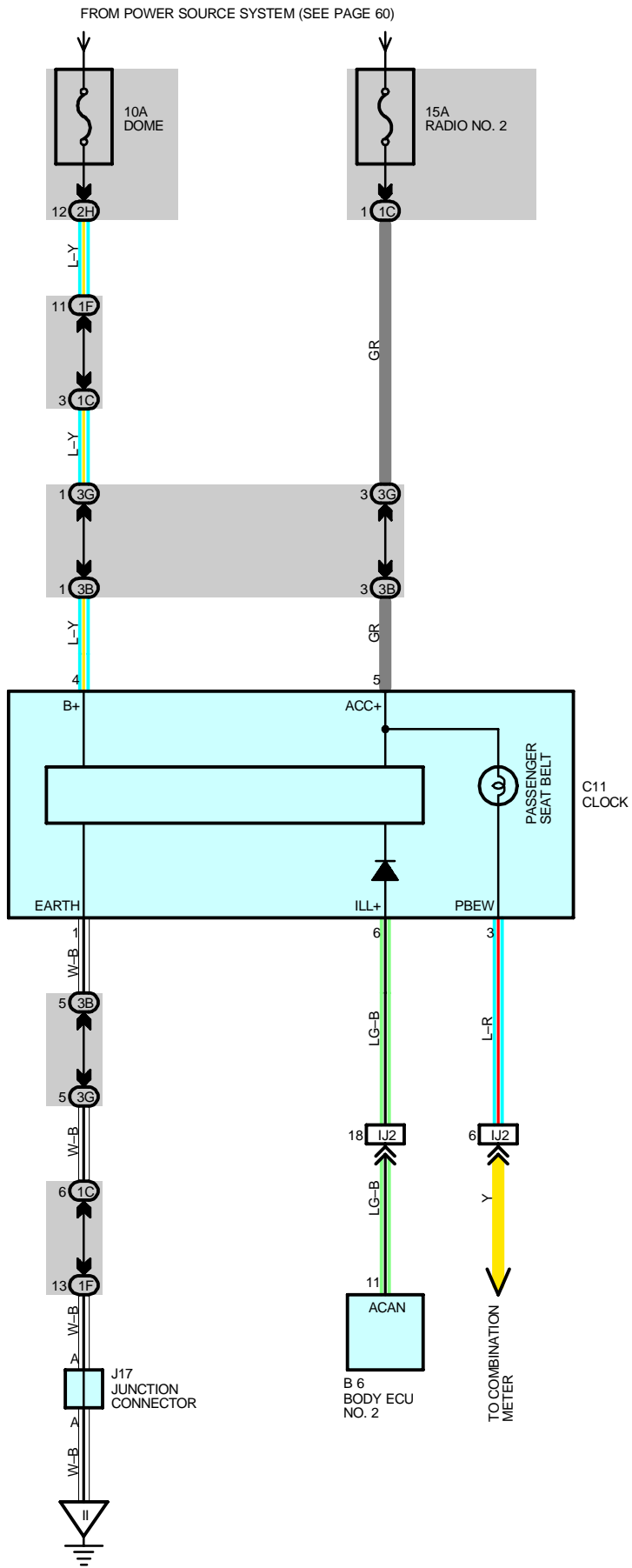

SERVICE HINTS

C11 CLOCK

- 4-GROUND : Always approx. **12** volts (Power for clock)
- 5-GROUND : Approx. **12** volts with ignition SW at **ACC** or **ON** position (Power for indication)
- 1-GROUND : Always continuity

○ : PARTS LOCATION

Code	See Page	Code	See Page	Code	See Page
B6	40	C11	40	J17	41

○ : JUNCTION BLOCK AND WIRE HARNESS CONNECTOR

Code	See Page	Junction Block and Wire Harness (Connector Location)
1C	26	Instrument Panel Wire and Driver Side J/B (Left Kick Panel)
1F	26	Cowl Wire and Driver Side J/B (Left Kick Panel)
2H	29	Cowl Wire and Passenger Side J/B (Right Kick Panel)
3B	30	Instrument Panel Wire and Instrument Panel J/B (Instrument Panel Reinforcement Center)
3G	31	

□ : CONNECTOR JOINING WIRE HARNESS AND WIRE HARNESS

Code	See Page	Joining Wire Harness and Wire Harness (Connector Location)
IJ2	52	Instrument Panel Wire and Cowl Wire (Left Side of the Blower Unit)

▽ : GROUND POINTS

Code	See Page	Ground Points Location
II	50	Right Side of the Cowl Panel

B6

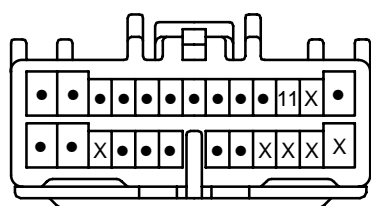

C11



J17

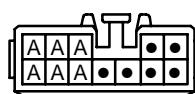

(Hint : See Page 7)

COMBINATION METER

FROM POWER SOURCE SYSTEM (SEE PAGE 60)

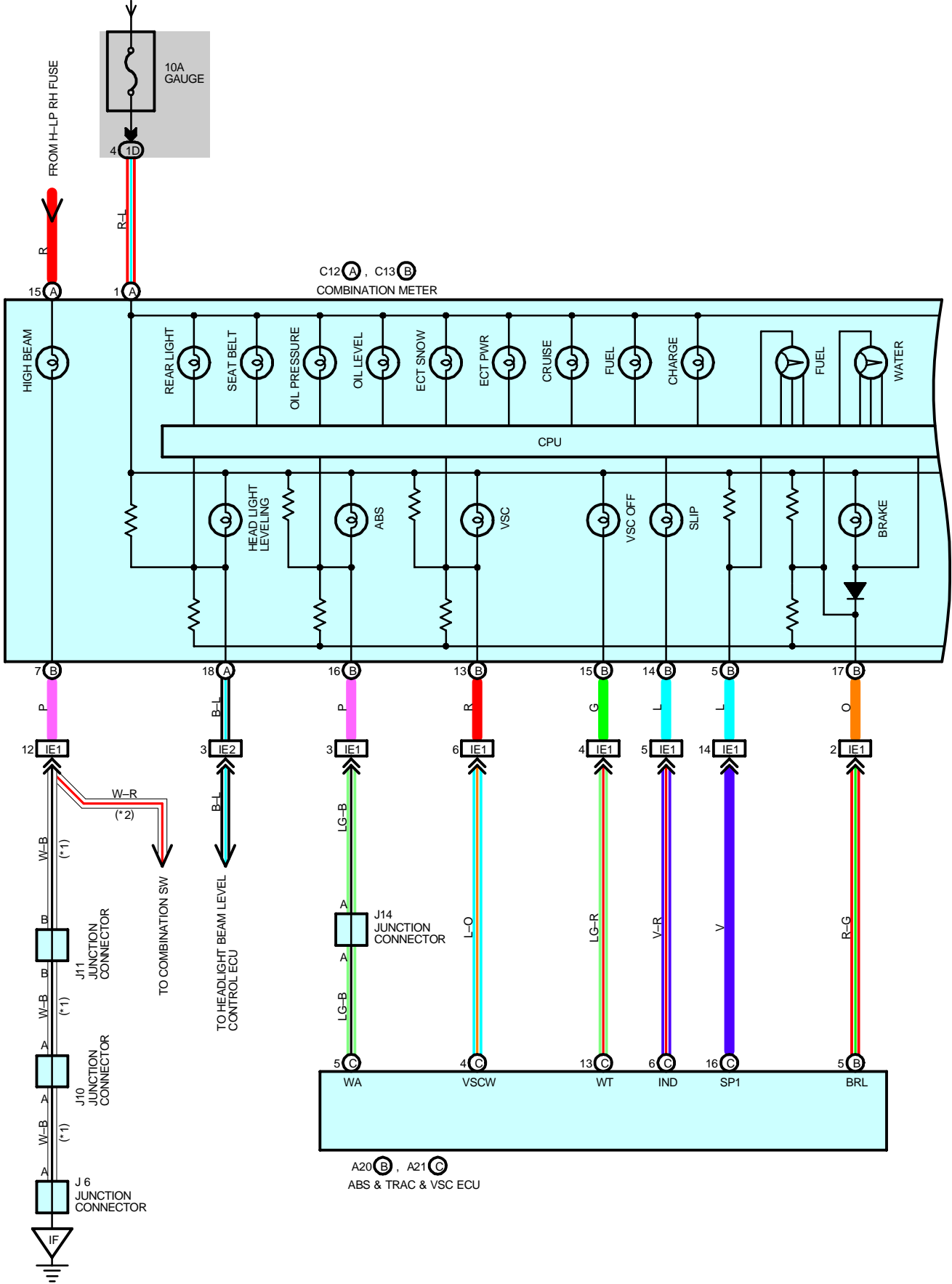

* 1 : W/ DAYTIME RUNNING LIGHT
 * 2 : W/O DAYTIME RUNNING LIGHT

* 3 : 1UZ-FE
 * 4 : 2JZ-GE

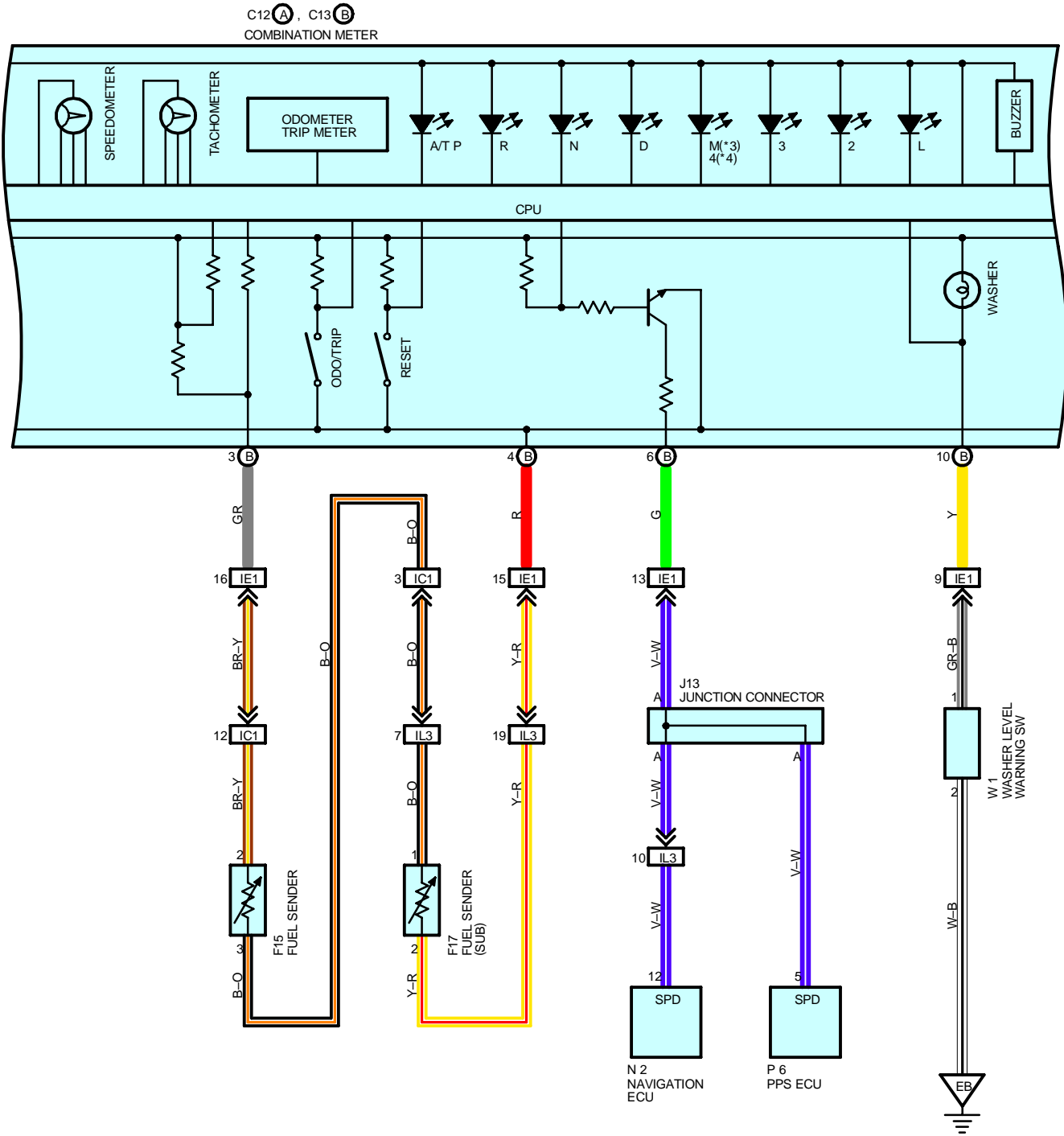

COMBINATION METER

FROM POWER SOURCE SYSTEM (SEE PAGE 60)

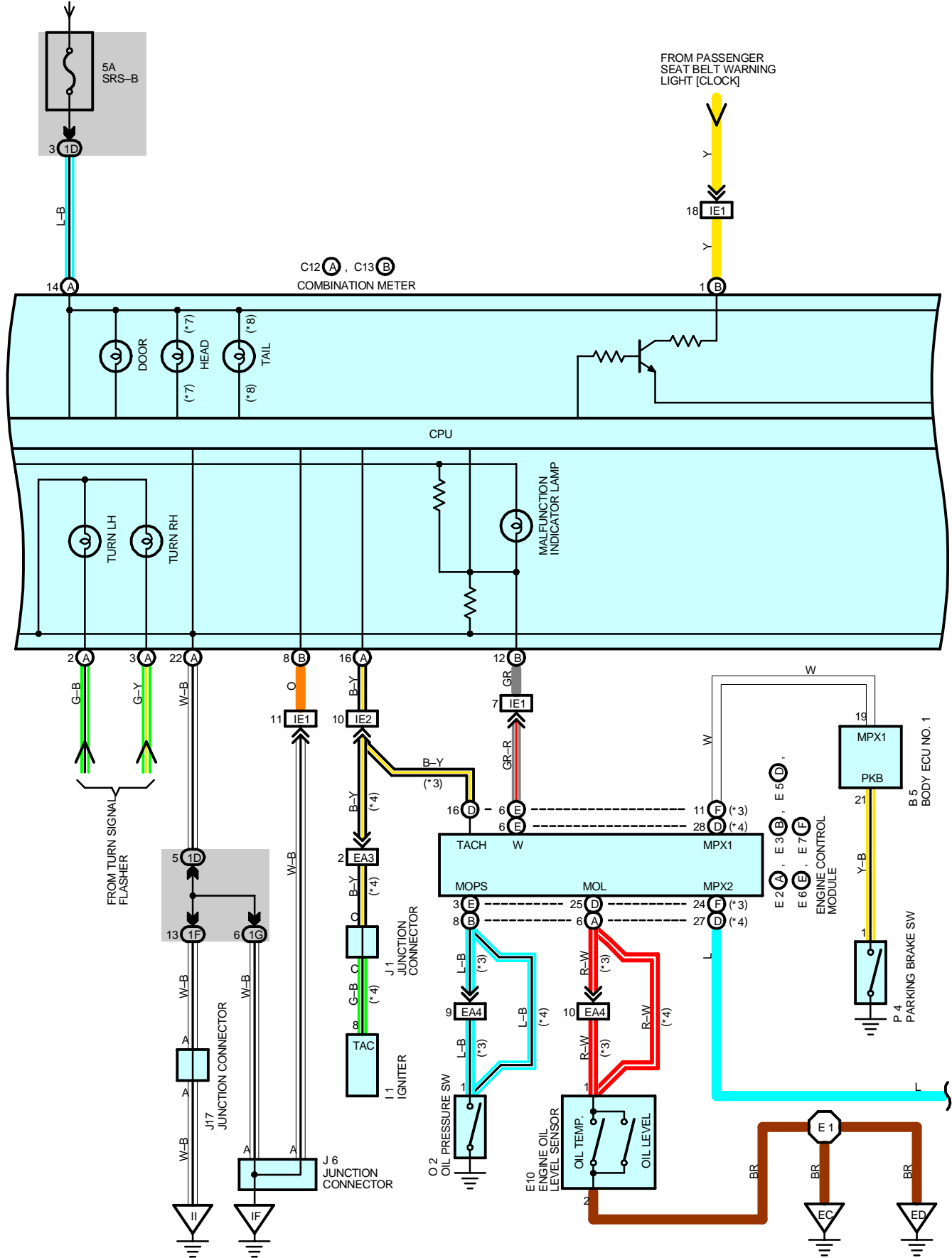

FROM POWER SOURCE SYSTEM (SEE PAGE 60)

- * 3 : 1UZ-FE * 5 : W/ LEXUS NAVIGATION SYSTEM * 7 : USA
- * 4 : 2JZ-GE * 6 : W/O LEXUS NAVIGATION SYSTEM * 8 : CANADA, TAIWAN
- * 9 : W/O DAYTIME RUNNING LIGHT * 10 : W/ DAYTIME RUNNING LIGHT

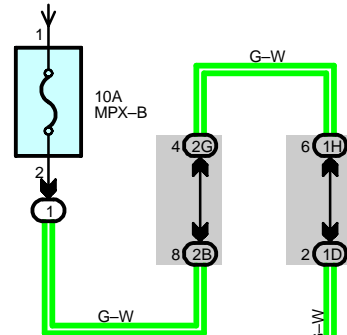

C12 (A), C13 (B)
COMBINATION METER

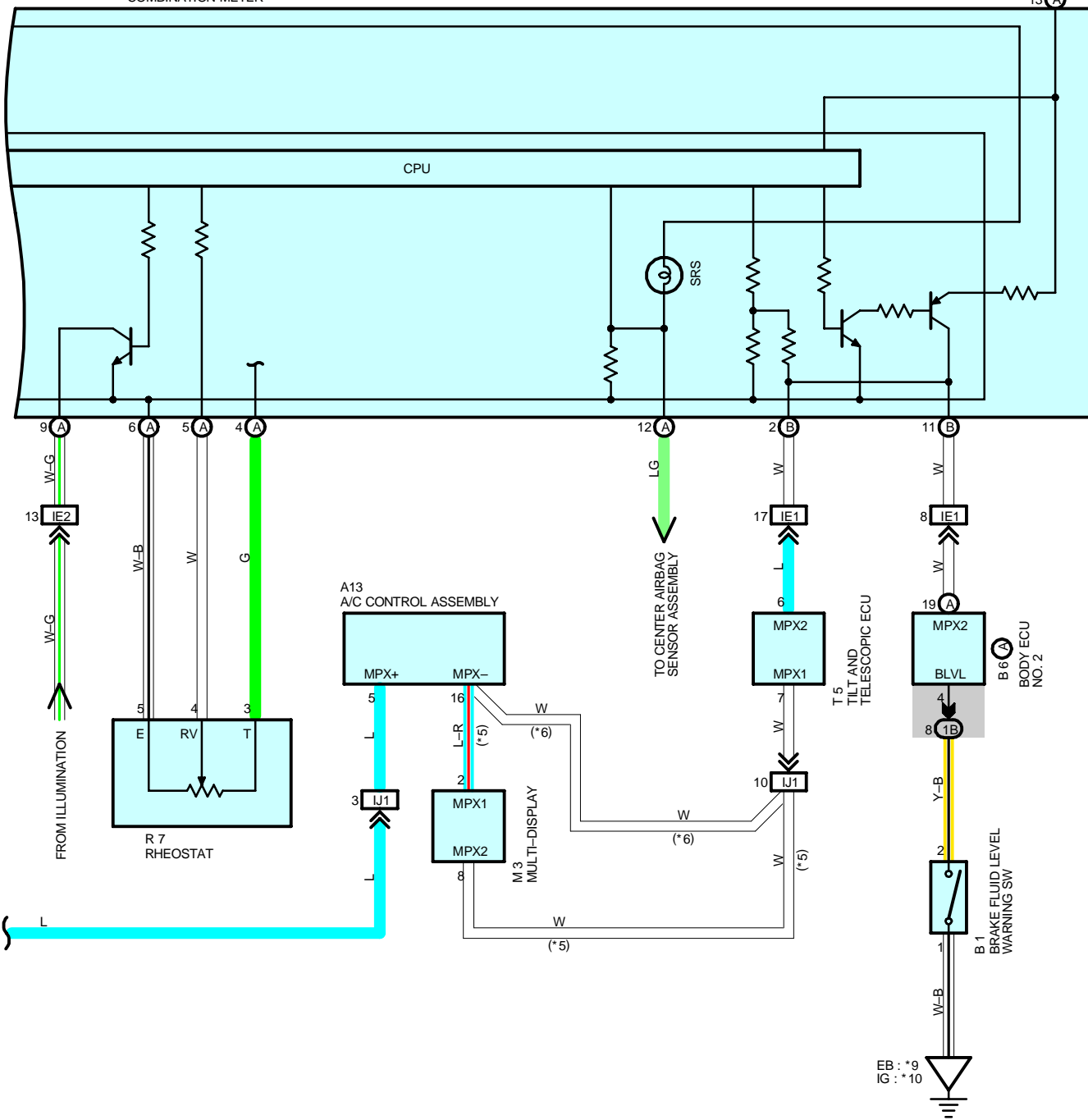

COMBINATION METER

SERVICE HINTS

B1 BRAKE FLUID LEVEL WARNING SW

1-2 : Closed with float down

P4 PARKING BRAKE SW

1-GROUND : Closed with parking brake pedal depressed

O2 OIL PRESSURE SW

1-GROUND : Closed with oil pressure below approx. **0.2 kgf/cm² (2.8 psi, 20 kpa)**

E10 ENGINE OIL LEVEL SENSOR

1-2 : Closed with float up and engine oil temp. at below approx. **50 °C (122 °F)**

Open with float down and engine oil temp. at above approx. **60 °C (140 °F)**

F15 FUEL SENDER

2-3 : Approx. **2.0 Ω** at fuel full

Approx. **48.7 Ω** at fuel empty

C12 (A), C13 (B) COMBINATION METER

(A) 1-GROUND : Approx. **12 volts** with ignition SW at **ON** or **ST** position

(A)22-GROUND : Always continuity

(B) 8-GROUND : Always continuity

(A)13-GROUND : Always approx. **12 volts**

(A)14-GROUND : Always approx. **12 volts**

○ : PARTS LOCATION

Code	See Page	Code	See Page	Code	See Page		
A13	40	E6	E	36 (1UZ-FE)	J14	41	
A20	B			40	38 (2JZ-GE)	J17	41
A21	C	40	E7	F	36 (1UZ-FE)	M3	41
B1	36 (1UZ-FE)		E10	36 (1UZ-FE)	N2	43	
	38 (2JZ-GE)			38 (2JZ-GE)	O2	37 (1UZ-FE)	
B5	40	F15	42	39 (2JZ-GE)			
B6	A	40	F17	42	P4	41	
C12	A	40	I1	39 (2JZ-GE)	P6	41	
C13	B	40	J1	39 (2JZ-GE)	R7	41	
E2	A	38 (2JZ-GE)	J6	41	T5	41	
E3	B	38 (2JZ-GE)	J10	41	W1	37 (1UZ-FE)	
E5	D	36 (1UZ-FE)	J11	41		39 (2JZ-GE)	
		38 (2JZ-GE)	J13	41			

○ : RELAY BLOCKS

Code	See Page	Relay Blocks (Relay Block Location)
1	22	Engine Room No.1 R/B (Engine Compartment Right)

○ : JUNCTION BLOCK AND WIRE HARNESS CONNECTOR

Code	See Page	Junction Block and Wire Harness (Connector Location)
1B	26	Cowl Wire and Driver Side J/B (Left Kick Panel)
1D	26	Instrument Panel Wire and Driver Side J/B (Left Kick Panel)
1F	26	Cowl Wire and Driver Side J/B (Left Kick Panel)
1G	27	
1H		
2B	28	Engine Room Main Wire and Passenger Side J/B (Right Kick Panel)
2G	29	Cowl Wire and Passenger Side J/B (Right Kick Panel)

 : CONNECTOR JOINING WIRE HARNESS AND WIRE HARNESS

Code	See Page	Joining Wire Harness and Wire Harness (Connector Location)
EA3	48 (2JZ-GE)	Engine Wire and Cowl Wire (Inside of the ECU Box)
EA4	46 (1UZ-FE)	
IC1	50	Floor No.2 Wire and Cowl Wire (Left Kick Panel)
IE1	50	Instrument Panel Wire and Cowl Wire (Left Side of the Steering Column)
IE2		
IL3	52	Floor No.1 Wire and Cowl Wire (Right Kick Panel)
IJ1	52	Instrument Panel Wire and Cowl Wire (Left Side of the Blower Unit)

 : GROUND POINTS

Code	See Page	Ground Points Location
EB	46 (1UZ-FE)	Left Fender
	48 (2JZ-GE)	
EC	46 (1UZ-FE)	RH Bank of the Cylinder Head
	48 (2JZ-GE)	Front Side of the Intake Manifold
ED	46 (1UZ-FE)	LH Bank of the Cylinder Head
	48 (2JZ-GE)	Rear Side of the Intake Manifold
IF	50	Left Kick Panel
IG	50	Left Side of the Cowl Panel
II	50	Right Side of the Cowl Panel

 : SPLICE POINTS

Code	See Page	Wire Harness with Splice Points	Code	See Page	Wire Harness with Splice Points
E1	46 (1UZ-FE)	Engine Wire	E1	48 (2JZ-GE)	Engine Wire

COMBINATION METER

A13

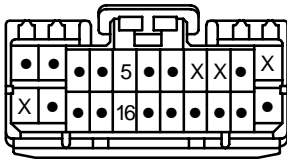

A20 (B)

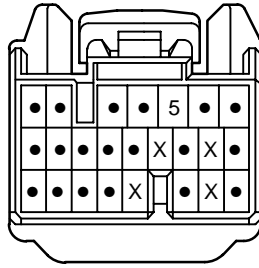

A21 (C)

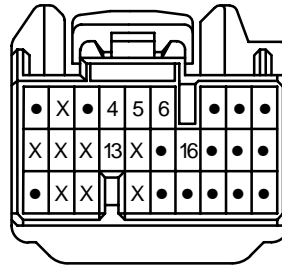

B1
GRAY



B5

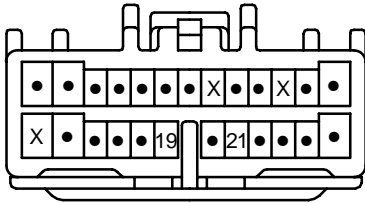

B6 (A)

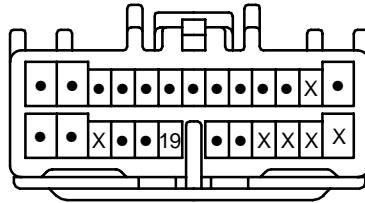

C12 (A)

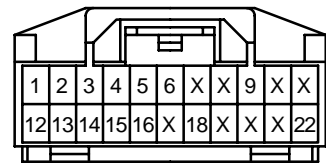

C13 (B)

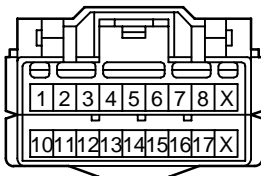

E2 (A)
(2JZ-GE)

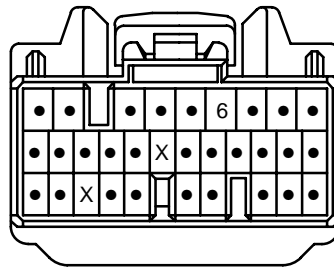

E3 (B)
(2JZ-GE)

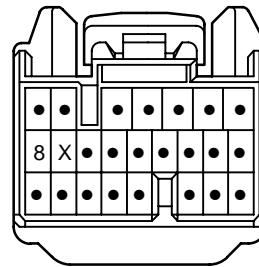

E5 (D)
(1UZ-FE)

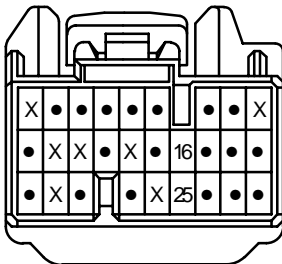

E5 (D)
(2JZ-GE)

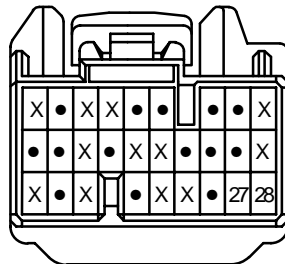

E6 (E)
(1UZ-FE)

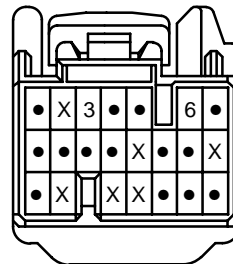

E6 (E)
(2JZ-GE)

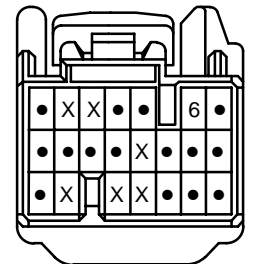

E7 (F)
(1UZ-FE)

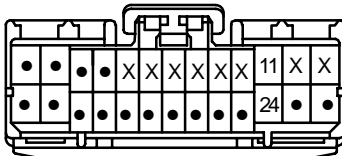

E10
GRAY



F15

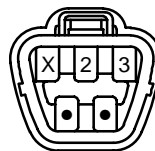

F17



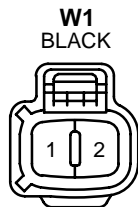
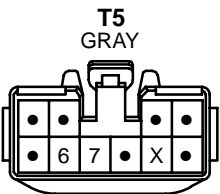
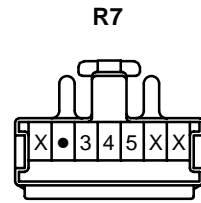
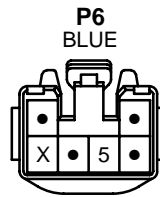
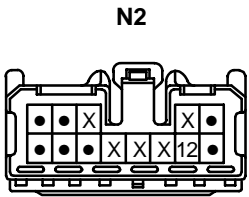
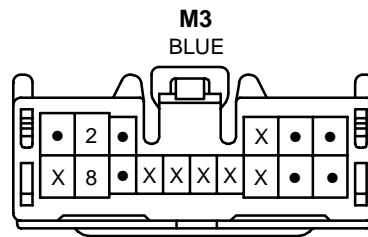
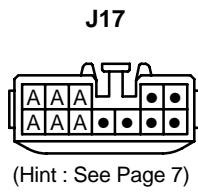
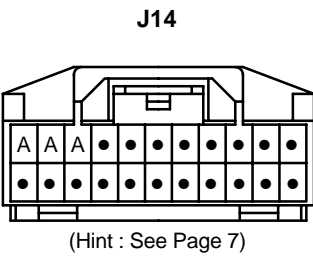
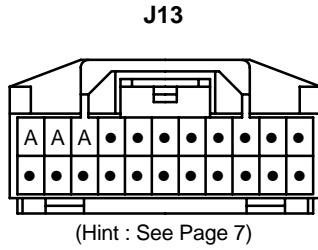
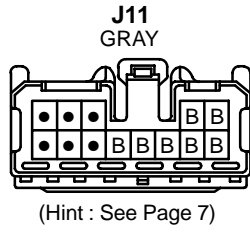
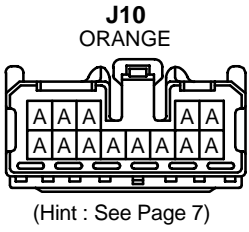
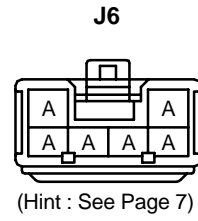
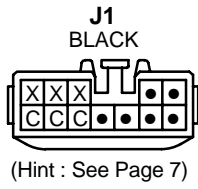
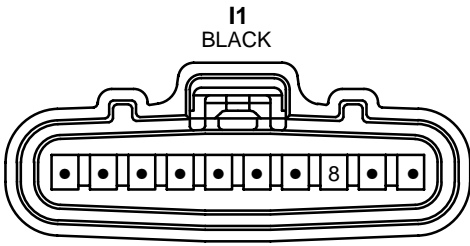

CRUISE CONTROL (1UZ-FE)

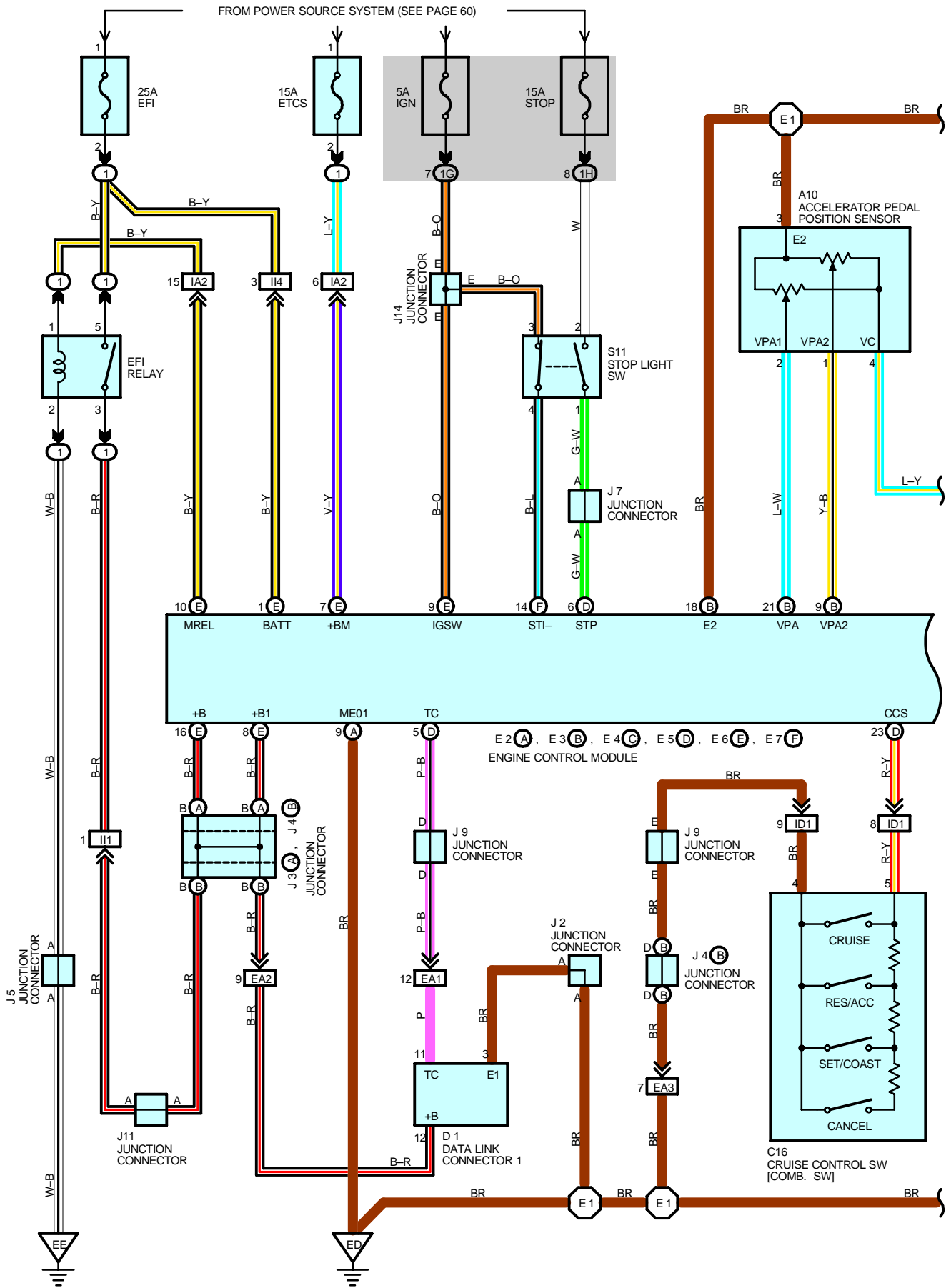

FROM POWER SOURCE SYSTEM (SEE PAGE 60)

* 1 : W/ LEXUS NAVIGATION SYSTEM
 * 2 : W/O LEXUS NAVIGATION SYSTEM

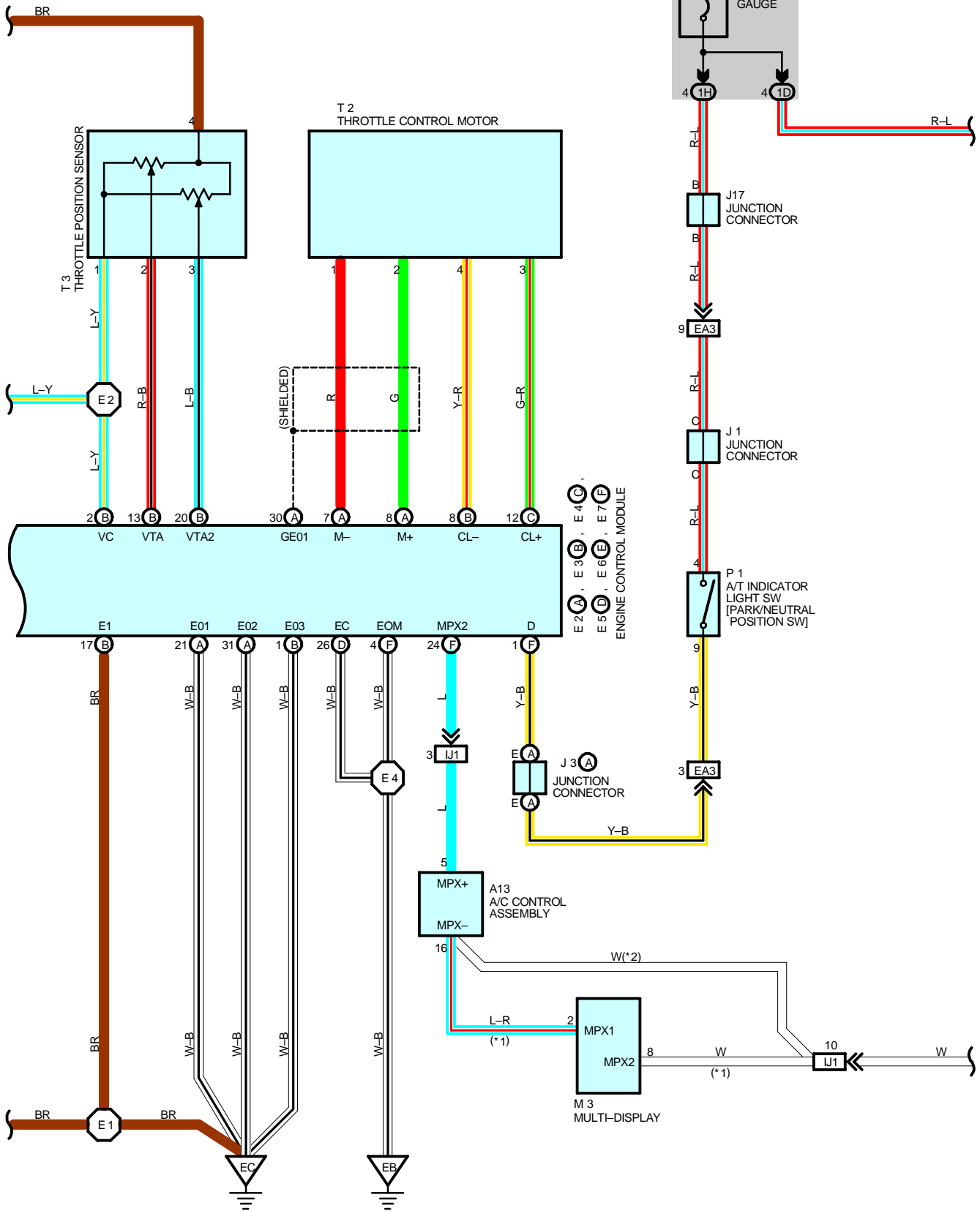

CRUISE CONTROL (1UZ-FE)

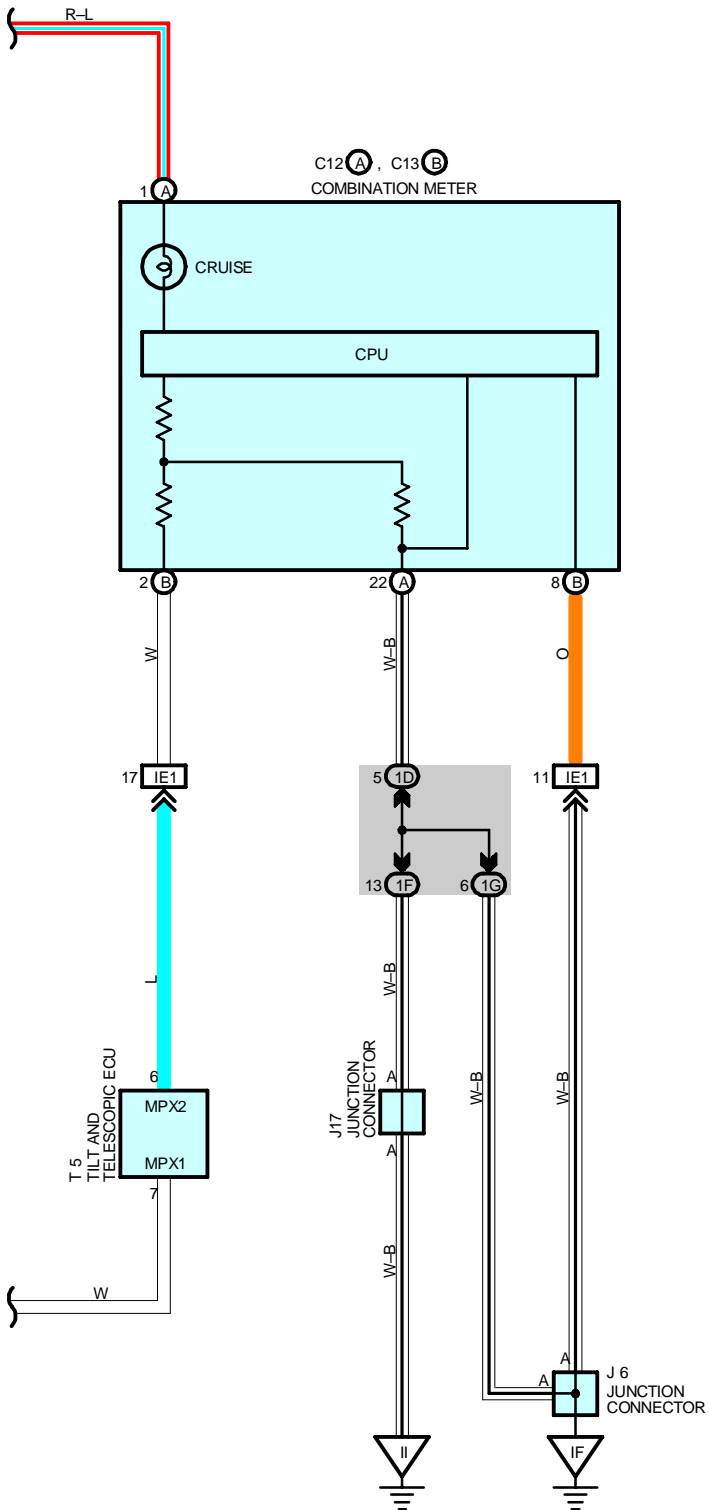

SYSTEM OUTLINE

The cruise control system is a constant vehicle speed controller in which control of the switch on the instrument panel makes it possible to automatically adjust the opening of the engine throttle valve without depressing of the accel. pedal.

1. SET OPERATION

When the cruise control main SW is turned on, the system starts preparations necessary for the cruise control and turns on the indicator light in the combination meter.

2. SET SPEED CONTROL

When the SET/COAST SW is operated with the cruise control main SW turned on during travelling, the constant vehicle speed is controlled.

3. COAST CONTROL

When the SET/COAST SW is kept turned on during cruise control travelling, the engine control module controls the throttle valve to decelerate the vehicle. Every time the SET/COAST SW is turned on instantaneously, the vehicle speed is decelerated approximately 1.5 km/h.

4. ACCEL CONTROL

When the RES/ACC SW is kept turned on during cruise control travelling, the engine control module controls the throttle valve to accelerate the vehicle. Every time the RES/ACC SW is turned on instantaneously, the vehicle speed is accelerated approximately 1.5 km/h.

5. RESUME CONTROL

When the vehicle speed is within the low speed limit (Approximately 40 km/h, 25 mph) if the cruise control is cancelled, use of the RES/ACC SW accelerates the vehicle to the speed level used before canceling the cruise control.

6. MANUAL CANCEL MECHANISM

If any of the following signals is input during cruise control travelling, the cruise control is cancelled.

- * The stop light SW is turned on.
- * The CANCEL SW is turned on.
- * The cruise control main SW is turned off.
- * The VSC is activated.

7. AUTO CANCEL FUNCTION

If any of the following conditions is encountered, the cruise control is automatically cancelled.

- * The stop light SW wiring is faulty or short-circuited.
- * The vehicle speed signal is faulty.
- * The electronically controlled throttle malfunctions.

8. OVERDRIVE CONTROL FUNCTION

The overdrive control may be cancelled if the vehicle travels on the slope during cruise control travelling. After the overdrive control has been cancelled, if the vehicle speed exceeds the overdrive return speed (The set speed is 2 km/h, 1.2 mph) and it is decided that the slope is finished, the vehicle returns to the overdrive control mode again.

SERVICE HINTS

E2 (A), E3 (B), E5 (D), E6 (E), E7 (F) ENGINE CONTROL MODULE

- (E) 9-GROUND : Approx. 12 volts with ignition SW at ON or ST position
- (E) 1-GROUND : Always approx. 12 volts
- (A) 9, (A) 21, (A) 31, (B) 1, (B) 17, (D) 26, (F) 4-GROUND : Always continuity
- (D) 6-GROUND : Approx. 12 volts with stop light SW at on
- (D)23-GROUND : Continuity with cruise control main SW at on
 - Approx. 1540 Ω with CANSEL SW on in cruise control SW
 - Approx. 240 Ω with RES/ACC SW on in cruise control SW
 - Approx. 630 Ω with SET/COAST SW on in cruise control SW

C16 CRUISE CONTROL SW [COMB. SW]

- 5-4 : Approx. 1540 Ω with CANSEL SW on
 - Approx. 240 Ω with RES/ACC SW on
 - Approx. 630 Ω with SET/COAST SW on

CRUISE CONTROL (1UZ-FE)

○ : PARTS LOCATION

Code		See Page	Code		See Page	Code		See Page
A10		36 (1UZ-FE)	E6	E	36 (1UZ-FE)	J11	41	
A13		40	E7	F	36 (1UZ-FE)	J14	41	
C12	A	40	J1		37 (1UZ-FE)	J17	41	
C13	B	40	J2		37 (1UZ-FE)	M3	41	
C16		40	J3	A	37 (1UZ-FE)	P1	37 (1UZ-FE)	
D1		36 (1UZ-FE)	J4	B	37 (1UZ-FE)	S11	41	
E2	A	36 (1UZ-FE)	J5		37 (1UZ-FE)	T2	37 (1UZ-FE)	
E3	B	36 (1UZ-FE)	J6		41	T3	37 (1UZ-FE)	
E4	C	36 (1UZ-FE)	J7		41	T5	41	
E5	D	36 (1UZ-FE)	J9		41			

○ : RELAY BLOCKS

Code	See Page	Relay Blocks (Relay Block Location)
1	22	Engine Room No.1 R/B (Engine Compartment Right)

○ : JUNCTION BLOCK AND WIRE HARNESS CONNECTOR

Code	See Page	Junction Block and Wire Harness (Connector Location)
1D	26	Instrument Panel Wire and Driver Side J/B (Left Kick Panel)
1F	26	Cowl Wire and Driver Side J/B (Left Kick Panel)
1G	27	
1H		

□ : CONNECTOR JOINING WIRE HARNESS AND WIRE HARNESS

Code	See Page	Joining Wire Harness and Wire Harness (Connector Location)
EA1	46 (1UZ-FE)	Engine Wire and Cowl Wire (Inside of the ECU Box)
EA2		
EA3		
IA2	50	Engine Room Main Wire and Cowl Wire (Near the Driver Side J/B)
ID1	50	Cowl Wire and Cowl Wire (Left Side of the Instrument Panel Reinforcement)
IE1	50	Instrument Panel Wire and Cowl Wire (Left Side of the Steering Column)
II1	52	Engine Room Main Wire and Cowl Wire (Near the Passenger Side R/B)
II4		
IJ1	52	Instrument Panel Wire and Cowl Wire (Left Side of the Blower Unit)

▽ : GROUND POINTS

Code	See Page	Ground Points Location
EB	46 (1UZ-FE)	Left Fender
EC	46 (1UZ-FE)	RH Bank of the Cylinder Head
ED	46 (1UZ-FE)	LH Bank of the Cylinder Head
EE	46 (1UZ-FE)	Under the ABS & TRAC & VSC Actuator
IF	50	Left Kick Panel
II	50	Right Side of the Cowl Panel

○ : SPLICE POINTS

Code	See Page	Wire Harness with Splice Points	Code	See Page	Wire Harness with Splice Points
E1	46 (1UZ-FE)	Engine Wire	E4	46 (1UZ-FE)	Cowl Wire
E2					

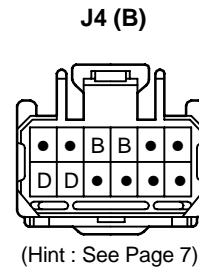
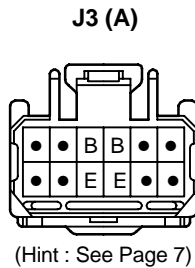
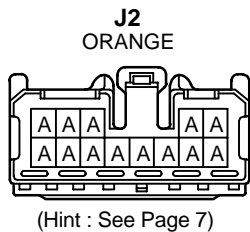
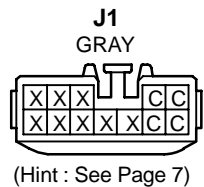
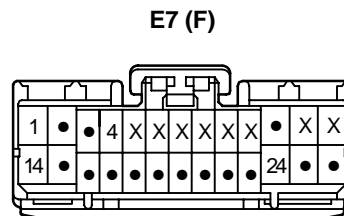
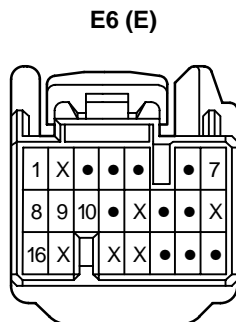
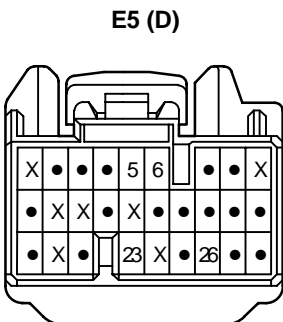
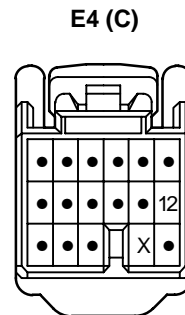
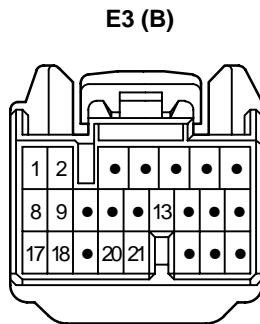
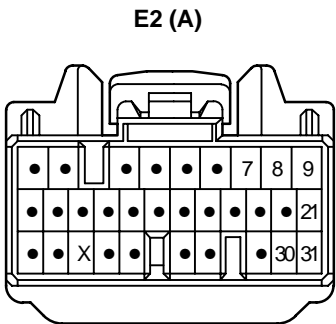
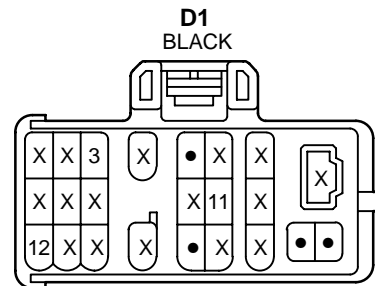
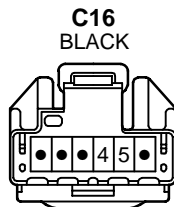
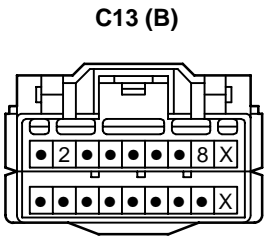
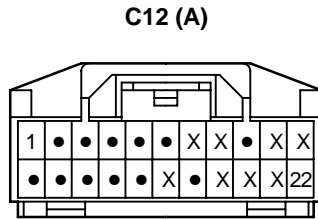
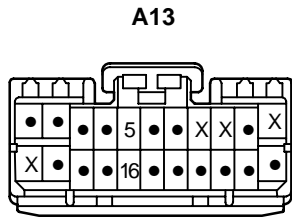

CRUISE CONTROL (1UZ-FE)

J5
BLUE



(Hint : See Page 7)

J6

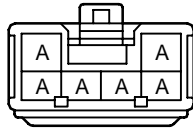

(Hint : See Page 7)

J7
GRAY

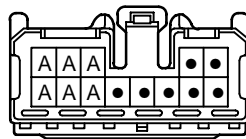

(Hint : See Page 7)

J9

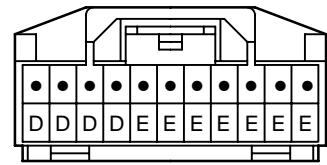

(Hint : See Page 7)

J11
GRAY

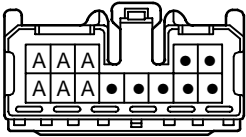

(Hint : See Page 7)

J14

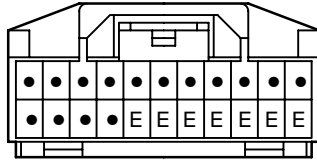

(Hint : See Page 7)

J17



(Hint : See Page 7)

M3
BLUE

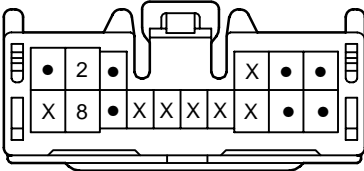

P1
GRAY

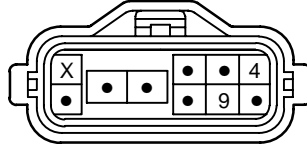

S11
BLUE

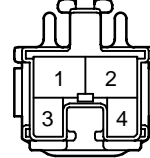

T2
GRAY



T3
GRAY

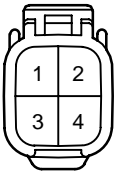

T5
GRAY

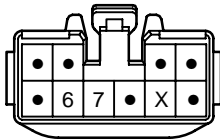

CRUISE CONTROL (2JZ-GE)

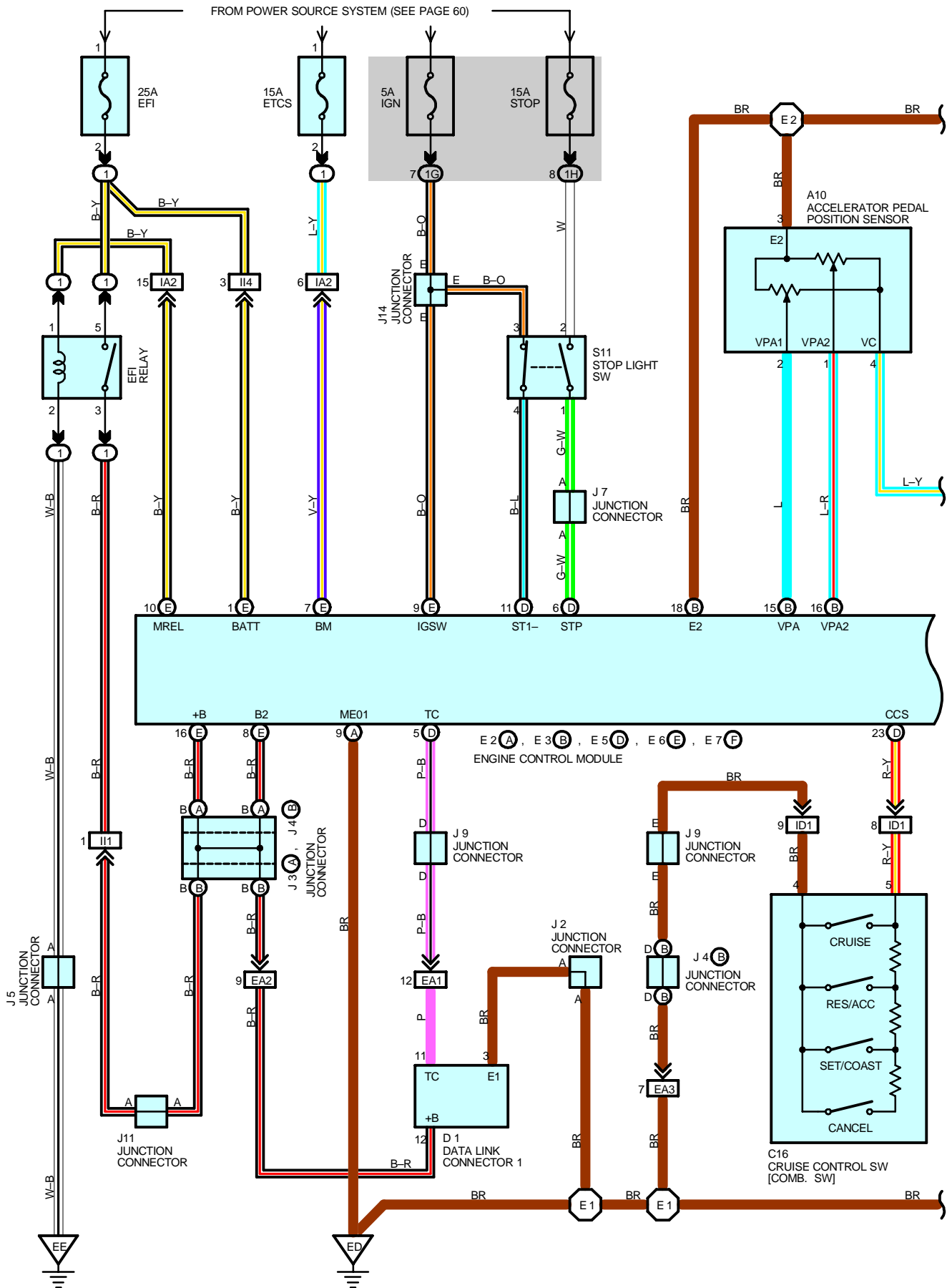

FROM POWER SOURCE SYSTEM (SEE PAGE 60)

- * 1 : W/ LEXUS NAVIGATION SYSTEM
- * 2 : W/O LEXUS NAVIGATION SYSTEM

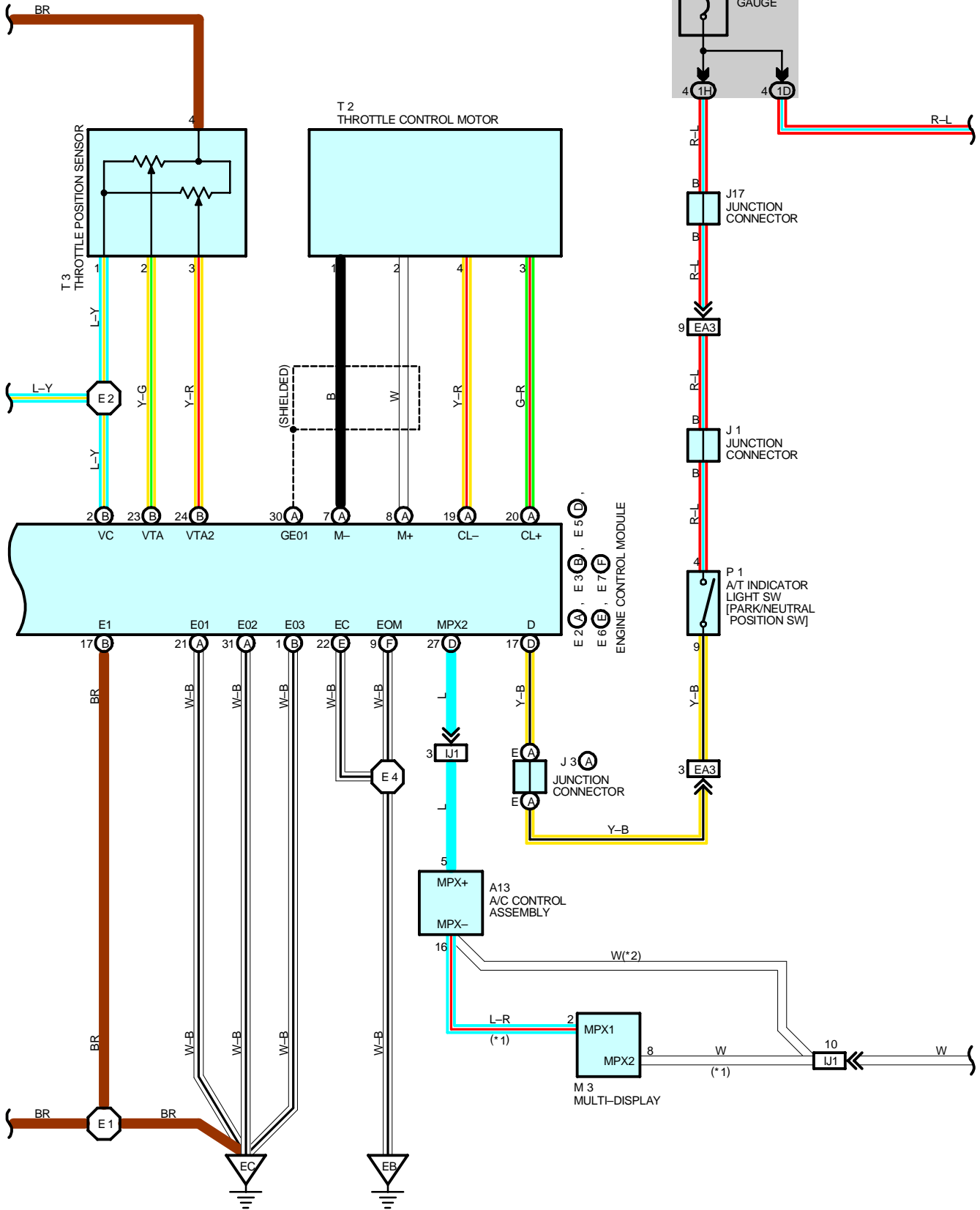

CRUISE CONTROL (2JZ-GE)

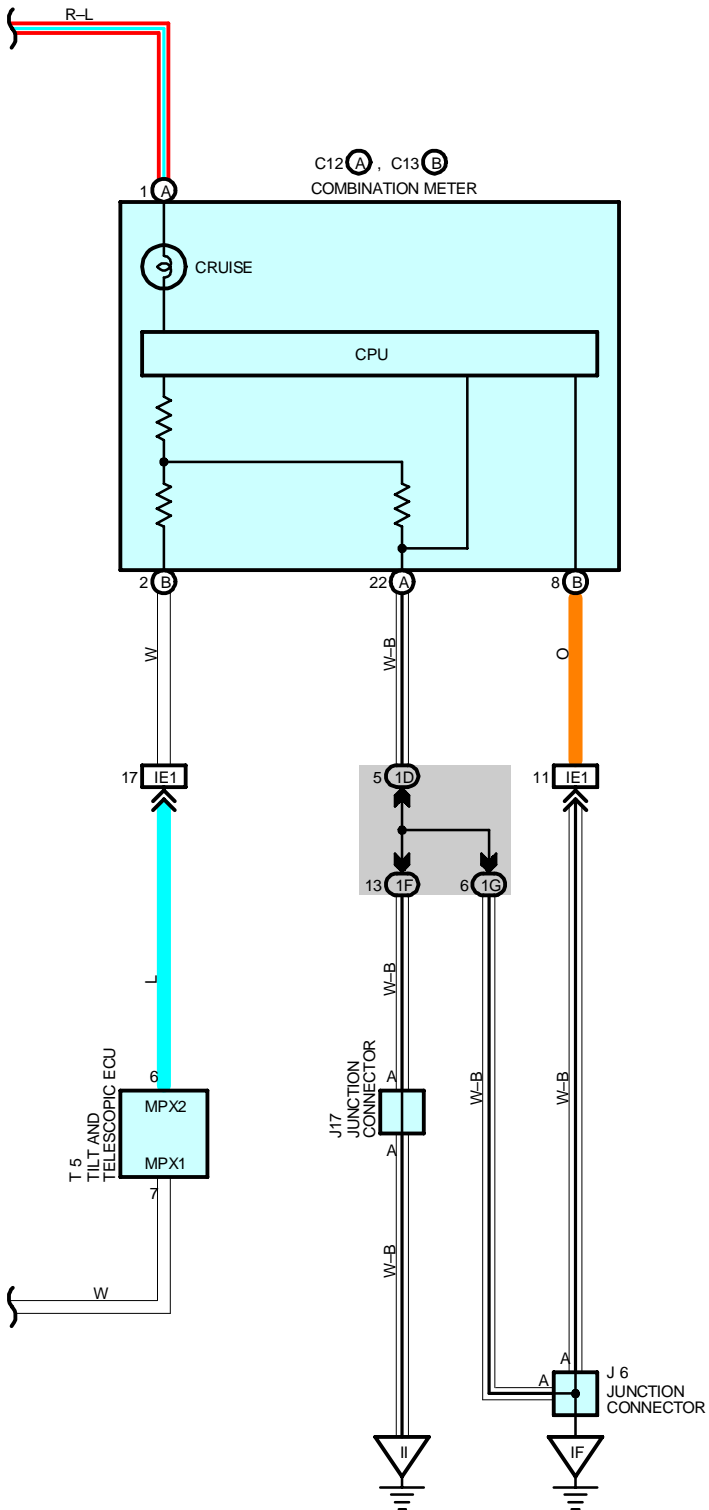

SYSTEM OUTLINE

The cruise control system is a constant vehicle speed controller in which control of the switch on the instrument panel makes it possible to automatically adjust the opening of the engine throttle valve without depressing of the accel. pedal.

1. SET OPERATION

When the cruise control main SW is turned on, the system starts preparations necessary for the cruise control and turns on the indicator light in the combination meter.

2. SET SPEED CONTROL

When the SET/COAST SW is operated with the cruise control main SW turned on during travelling, the constant vehicle speed is controlled.

3. COAST CONTROL

When the SET/COAST SW is kept turned on during cruise control travelling, the engine control module controls the throttle valve to decelerate the vehicle. Every time the SET/COAST SW is turned on instantaneously, the vehicle speed is decelerated approximately 1.5 km/h.

4. ACCEL CONTROL

When the RES/ACC SW is kept turned on during cruise control travelling, the engine control module controls the throttle valve to accelerate the vehicle. Every time the RES/ACC SW is turned on instantaneously, the vehicle speed is accelerated approximately 1.5 km/h.

5. RESUME CONTROL

When the vehicle speed is within the low speed limit (Approximately 40 km/h, 25 mph) if the cruise control is cancelled, use of the RES/ACC SW accelerates the vehicle to the speed level used before canceling the cruise control.

6. MANUAL CANCEL MECHANISM

If any of the following signals is input during cruise control travelling, the cruise control is cancelled.

- * The stop light SW is turned on.
- * The CANCEL SW is turned on.
- * The cruise control main SW is turned off.
- * The VSC is activated.

7. AUTO CANCEL FUNCTION

If any of the following conditions is encountered, the cruise control is automatically cancelled.

- * The stop light SW wiring is faulty or short-circuited.
- * The vehicle speed signal is faulty.
- * The electronically controlled throttle malfunctions.

8. OVERDRIVE CONTROL FUNCTION

The overdrive control may be cancelled if the vehicle travels on the slope during cruise control travelling. After the overdrive control has been cancelled, if the vehicle speed exceeds the overdrive return speed (The set speed is 2 km/h, 1.2 mph) and it is decided that the slope is finished, the vehicle returns to the overdrive control mode again.

SERVICE HINTS

E2 (A), E3 (B), E5 (D), E6 (E), E7 (F) ENGINE CONTROL MODULE

- (E) 9-GROUND : Approx. 12 volts with ignition SW at ON or ST position
- (E) 1-GROUND : Always approx. 12 volts
- (A) 9, (A) 21, (A) 31, (B) 1, (B) 17, (E) 22, (F) 9-GROUND : Always continuity
- (D) 6-GROUND : Approx. 12 volts with stop light SW at on
- (D)23-GROUND : Continuity with cruise control main SW at on
 - Approx. 1540 Ω with CANCEL SW on in cruise control SW
 - Approx. 240 Ω with RES/ACC SW on in cruise control SW
 - Approx. 630 Ω with SET/COAST SW on in cruise control SW

C16 CRUISE CONTROL SW [COMB. SW]

- 5-4 : Approx. 1540 Ω with CANCEL SW on
 - Approx. 240 Ω with RES/ACC SW on
 - Approx. 630 Ω with SET/COAST SW on

CRUISE CONTROL (2JZ-GE)

: PARTS LOCATION

Code	See Page	Code	See Page	Code	See Page		
A10	38 (2JZ-GE)	E7	F	38 (2JZ-GE)	J14	41	
A13	40	J1		39 (2JZ-GE)	J17	41	
C12	A	40	J2	39 (2JZ-GE)	M3	41	
C13	B	40	J3	A	39 (2JZ-GE)	P1	39 (2JZ-GE)
C16	40	J4	B	39 (2JZ-GE)	S11	41	
D1	38 (2JZ-GE)	J5		39 (2JZ-GE)	T2	39 (2JZ-GE)	
E2	A	38 (2JZ-GE)	J6	41	T3	39 (2JZ-GE)	
E3	B	38 (2JZ-GE)	J7	41	T5	41	
E5	D	38 (2JZ-GE)	J9	41			
E6	E	38 (2JZ-GE)	J11	41			

: RELAY BLOCKS

Code	See Page	Relay Blocks (Relay Block Location)
1	22	Engine Room No.1 R/B (Engine Compartment Right)

: JUNCTION BLOCK AND WIRE HARNESS CONNECTOR

Code	See Page	Junction Block and Wire Harness (Connector Location)
1D	26	Instrument Panel Wire and Driver Side J/B (Left Kick Panel)
1F	26	Cowl Wire and Driver Side J/B (Left Kick Panel)
1G	27	
1H		

: CONNECTOR JOINING WIRE HARNESS AND WIRE HARNESS

Code	See Page	Joining Wire Harness and Wire Harness (Connector Location)
EA1	48 (2JZ-GE)	Engine Wire and Cowl Wire (Inside of the ECU Box)
EA2		
EA3		
IA2	50	Engine Room Main Wire and Cowl Wire (Near the Driver Side J/B)
ID1	50	Cowl Wire and Cowl Wire (Left Side of the Instrument Panel Reinforcement)
IE1	50	Instrument Panel Wire and Cowl Wire (Left Side of the Steering Column)
II1	52	Engine Room Main Wire and Cowl Wire (Near the Passenger Side R/B)
II4		
IJ1	52	Instrument Panel Wire and Cowl Wire (Left Side of the Blower Unit)

: GROUND POINTS

Code	See Page	Ground Points Location
EB	48 (2JZ-GE)	Left Fender
EC	48 (2JZ-GE)	Front Side of the Intake Manifold
ED	48 (2JZ-GE)	Rear Side of the Intake Manifold
EE	48 (2JZ-GE)	Under the ABS & TRAC & VSC Actuator
IF	50	Left Kick Panel
II	50	Right Side of the Cowl Panel

: SPLICE POINTS

Code	See Page	Wire Harness with Splice Points	Code	See Page	Wire Harness with Splice Points
E1	48 (2JZ-GE)	Engine Wire	E4	48 (2JZ-GE)	Cowl Wire
E2					

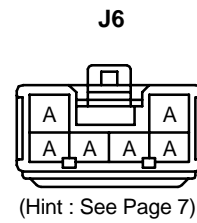
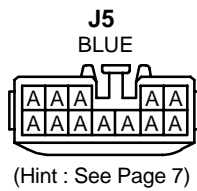
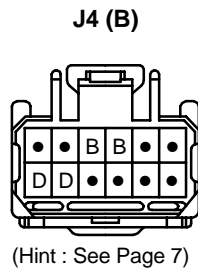
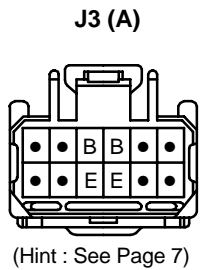
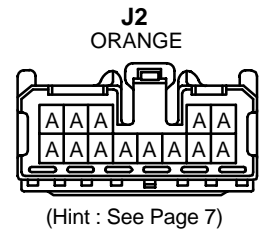
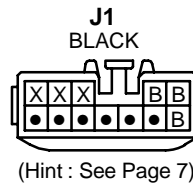
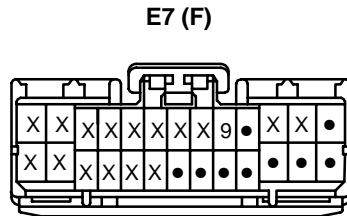
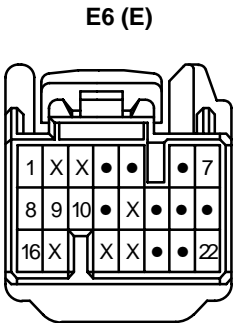
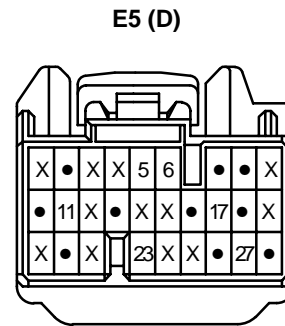
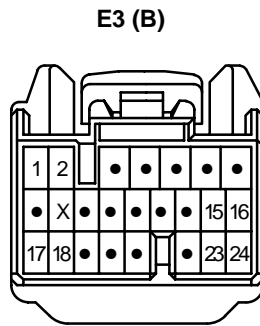
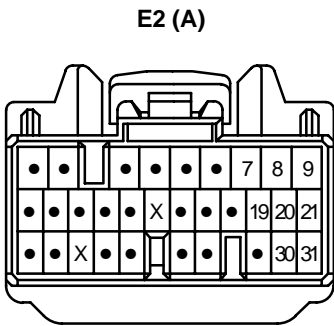
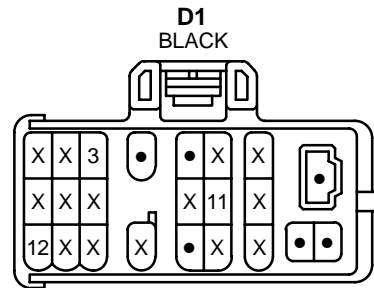
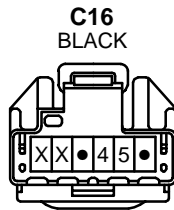
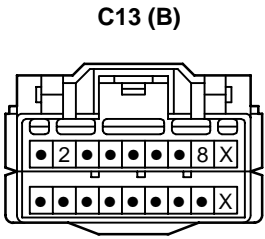
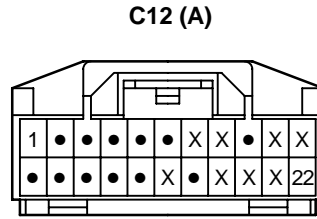
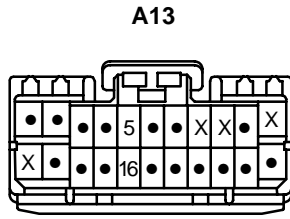

CRUISE CONTROL (2JZ-GE)

J7
GRAY

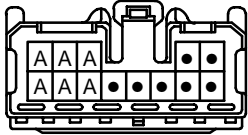

(Hint : See Page 7)

J9

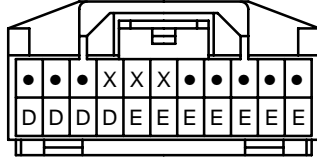

(Hint : See Page 7)

J11
GRAY

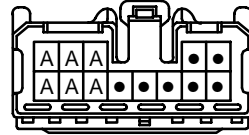

(Hint : See Page 7)

J14

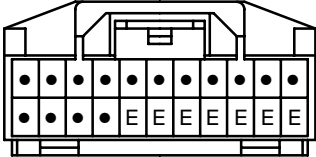

(Hint : See Page 7)

J17



(Hint : See Page 7)

M3
BLUE

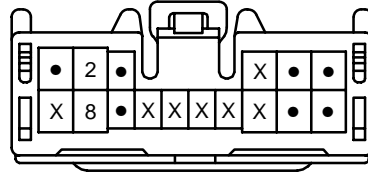

P1
GRAY

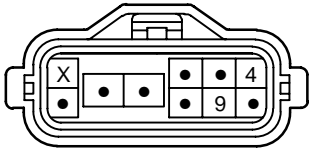

S11
BLUE

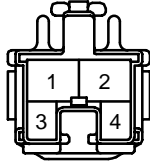

T2
GRAY



T3
BLACK



T5
GRAY

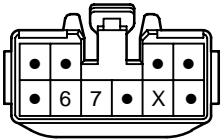

ELECTRIC TENSION REDUCER

FROM POWER SOURCE SYSTEM (SEE PAGE 60)

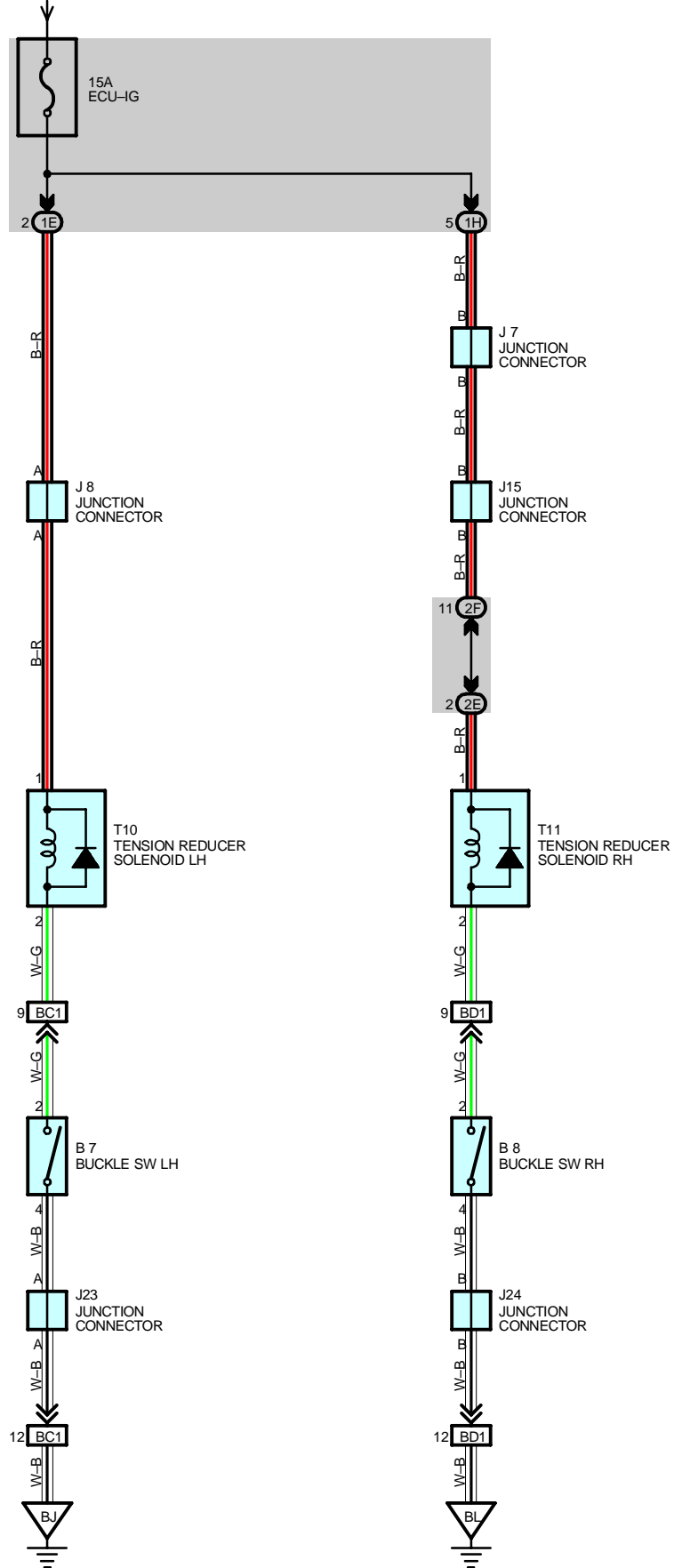

SERVICE HINTS

B7 BUCKLE SW LH

1-3 : Closed with driver seat belt in use

B8 BUCKLE SW RH

1-3 : Closed with front passenger seat belt in use

T10, T11 TENSION REDUCER SOLENOID LH, RH

1-GROUND : Approx. 12 volts with ignition SW at ON position

○ : PARTS LOCATION

Code	See Page	Code	See Page	Code	See Page
B7	44	J8	41	J24	44
B8	44	J15	41	T10	43
J7	41	J23	44	T11	43

○ : JUNCTION BLOCK AND WIRE HARNESS CONNECTOR

Code	See Page	Junction Block and Wire Harness (Connector Location)
1E	26	Floor No.2 Wire and Driver Side J/B (Left Kick Panel)
1H	27	Cowl Wire and Driver Side J/B (Left Kick Panel)
2E	28	Floor No.1 Wire and Passenger Side J/B (Right Kick Panel)
2F	28	Cowl Wire and Passenger Side J/B (Right Kick Panel)

□ : CONNECTOR JOINING WIRE HARNESS AND WIRE HARNESS

Code	See Page	Joining Wire Harness and Wire Harness (Connector Location)
BC1	56	Floor No.2 Wire and Front Seat LH Wire (Under the Driver's Seat)
BD1	56	Floor No.1 Wire and Front Seat RH Wire (Under the Front Passenger's Seat)

▽ : GROUND POINTS

Code	See Page	Ground Points Location
BJ	54	Rear Floor Partition Panel LH
BL	54	Rear Floor Partition Panel RH

B7

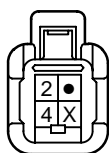

B8

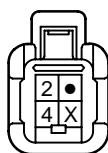

J7
GRAY

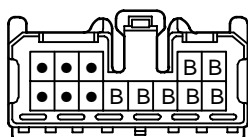

(Hint : See Page 7)

J8
BLACK



(Hint : See Page 7)

J15

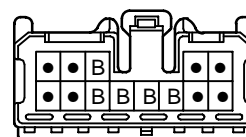

(Hint : See Page 7)

J23

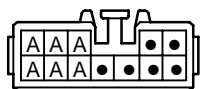

(Hint : See Page 7)

J24

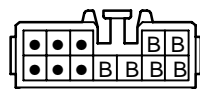

(Hint : See Page 7)

T10



T11



ELECTRONICALLY CONTROLLED TRANSMISSION

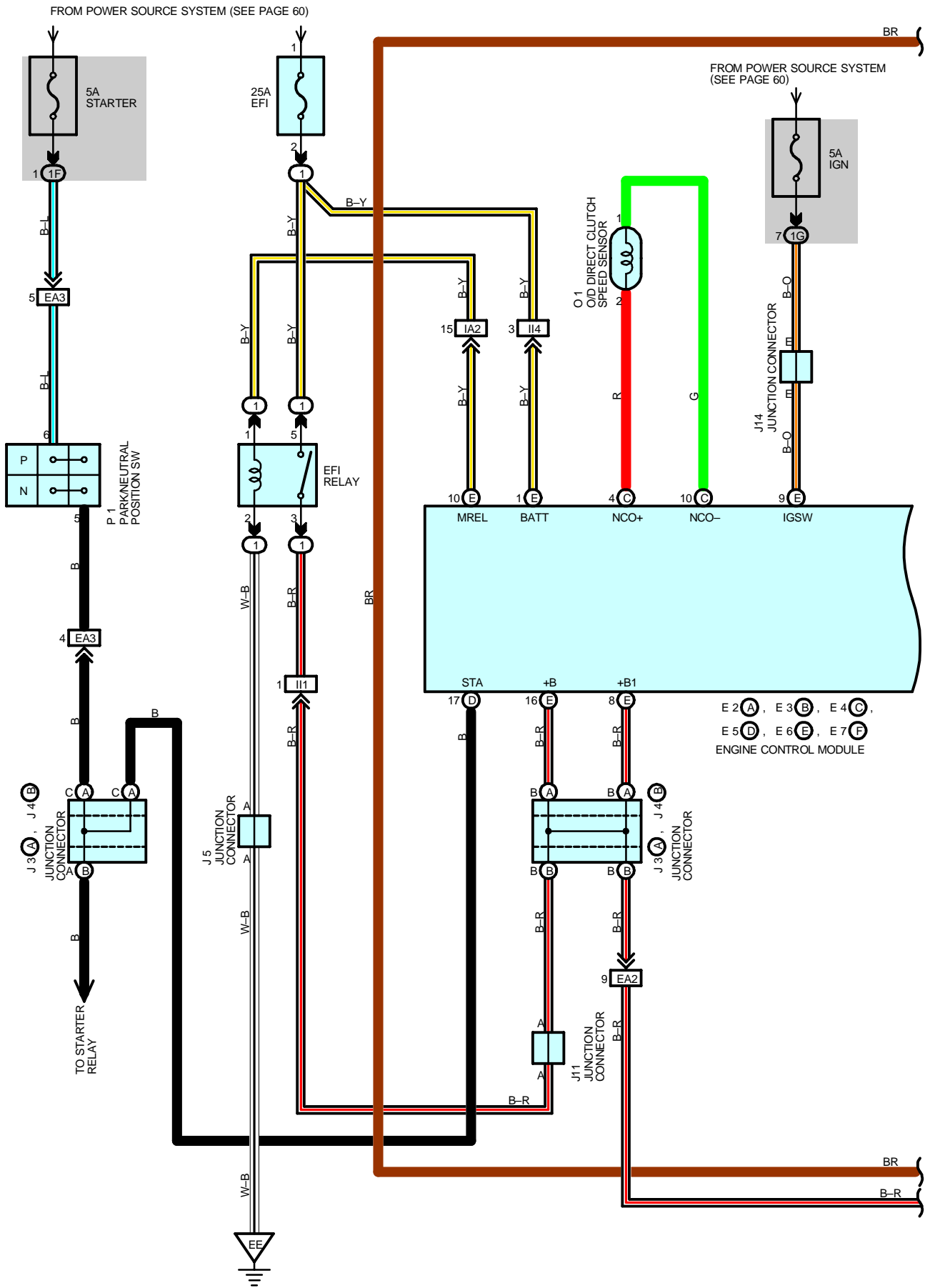

AND A/T INDICATOR (1UZ-FE)

FROM POWER SOURCE SYSTEM (SEE PAGE 60)

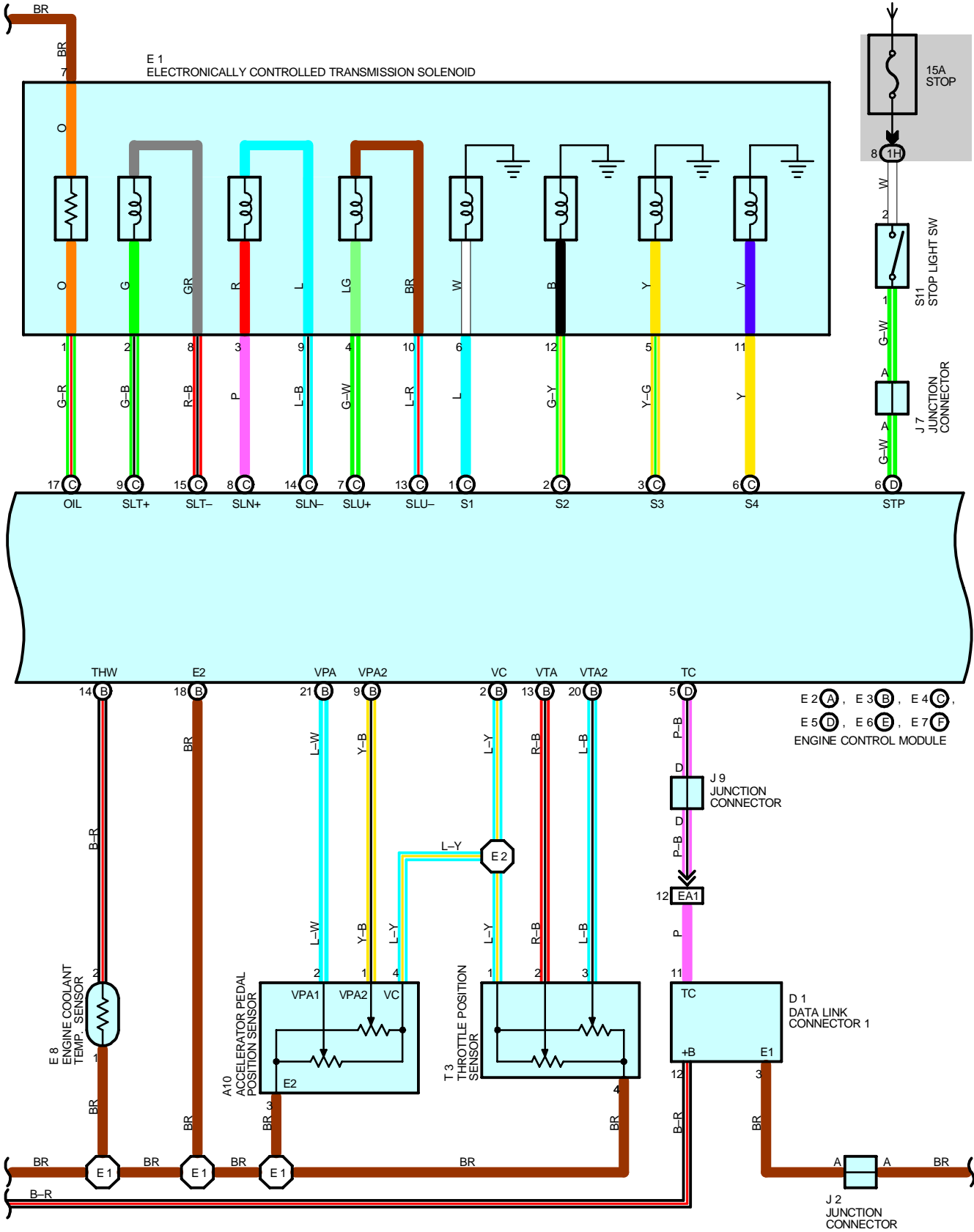

ELECTRONICALLY CONTROLLED TRANSMISSION

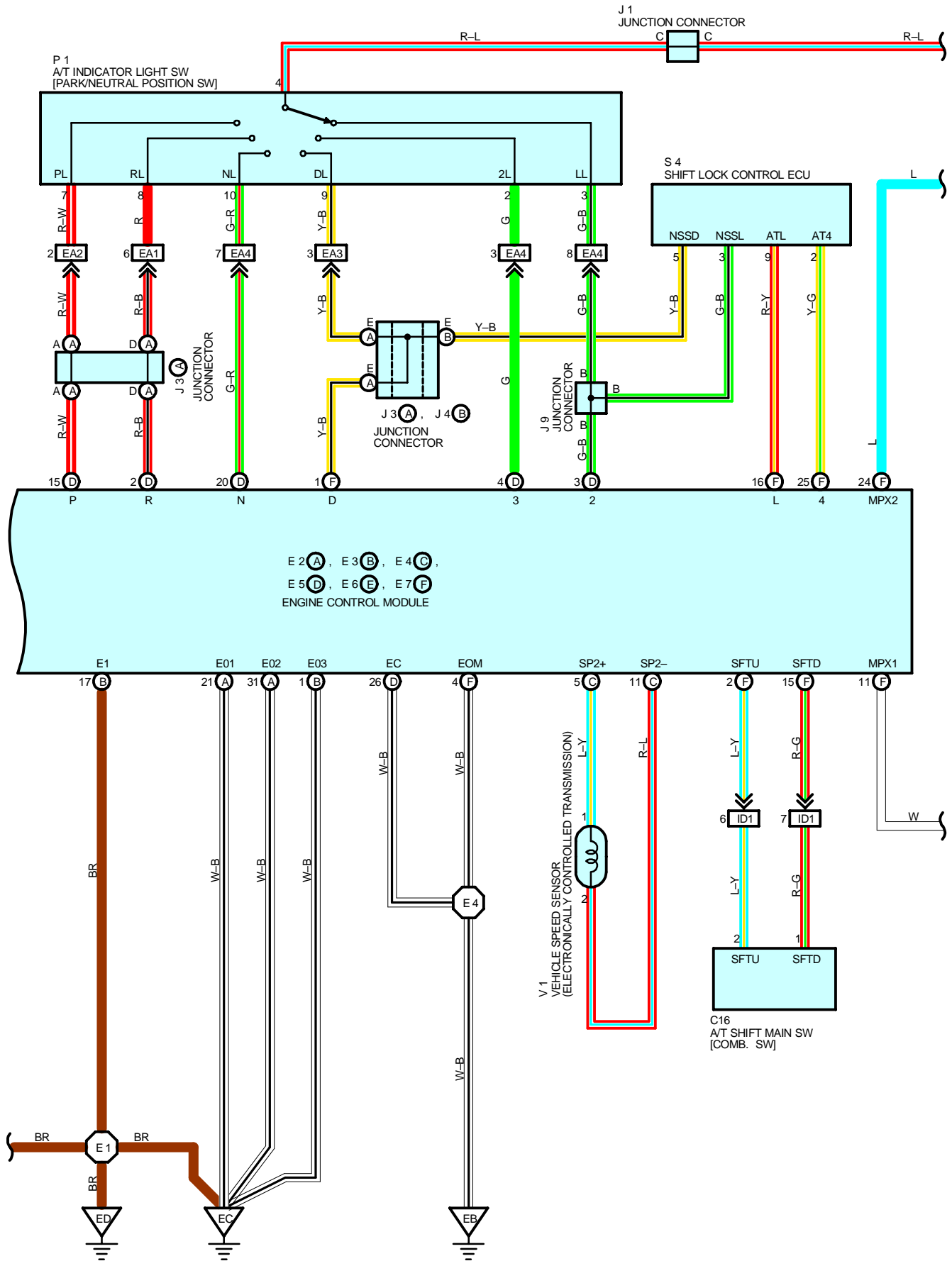

AND A/T INDICATOR (1UZ-FE)

* 1 : W/ LEXUS NAVIGATION SYSTEM
 * 2 : W/O LEXUS NAVIGATION SYSTEM

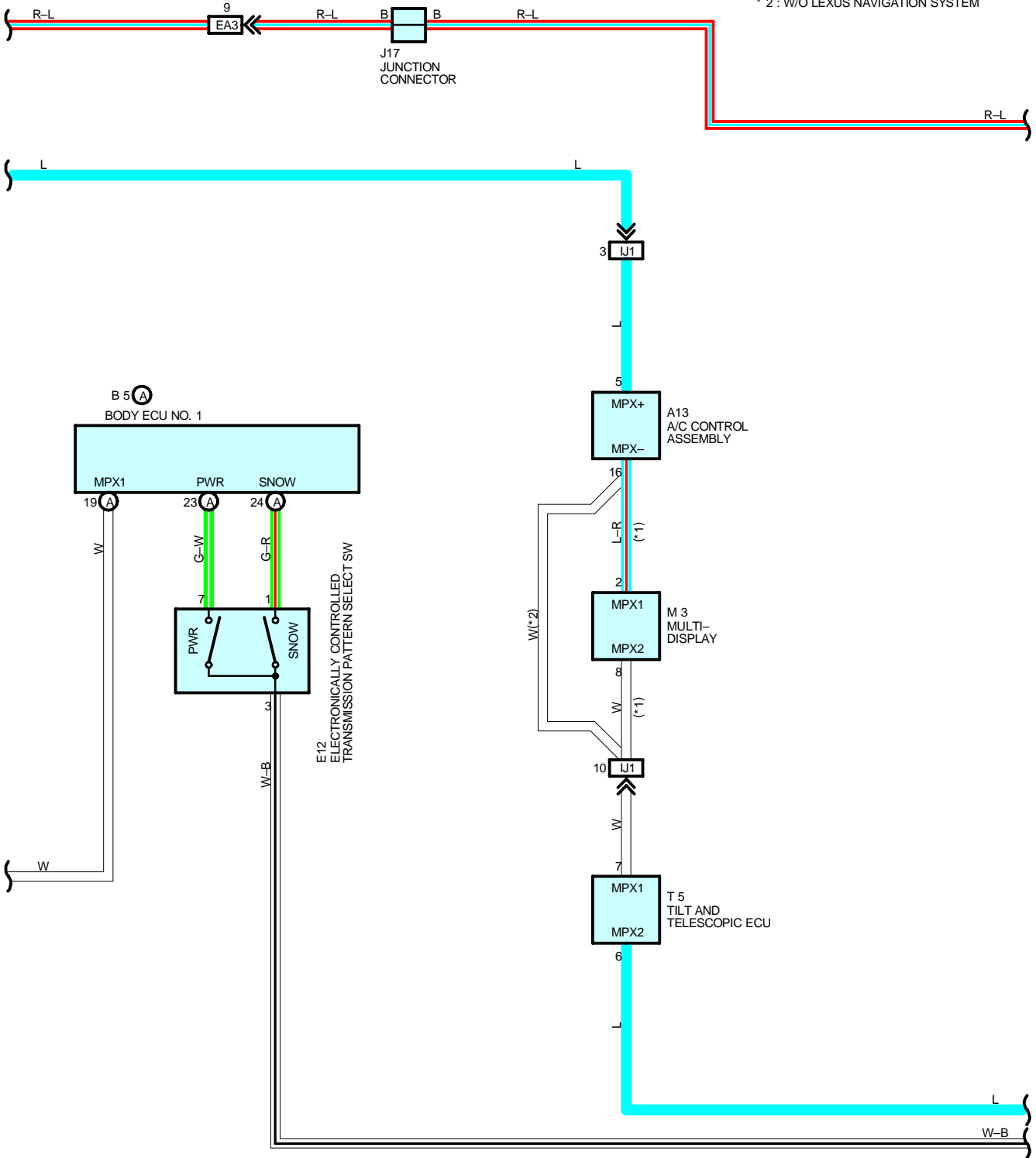

ELECTRONICALLY CONTROLLED TRANSMISSION

FROM POWER SOURCE SYSTEM (SEE PAGE 60)

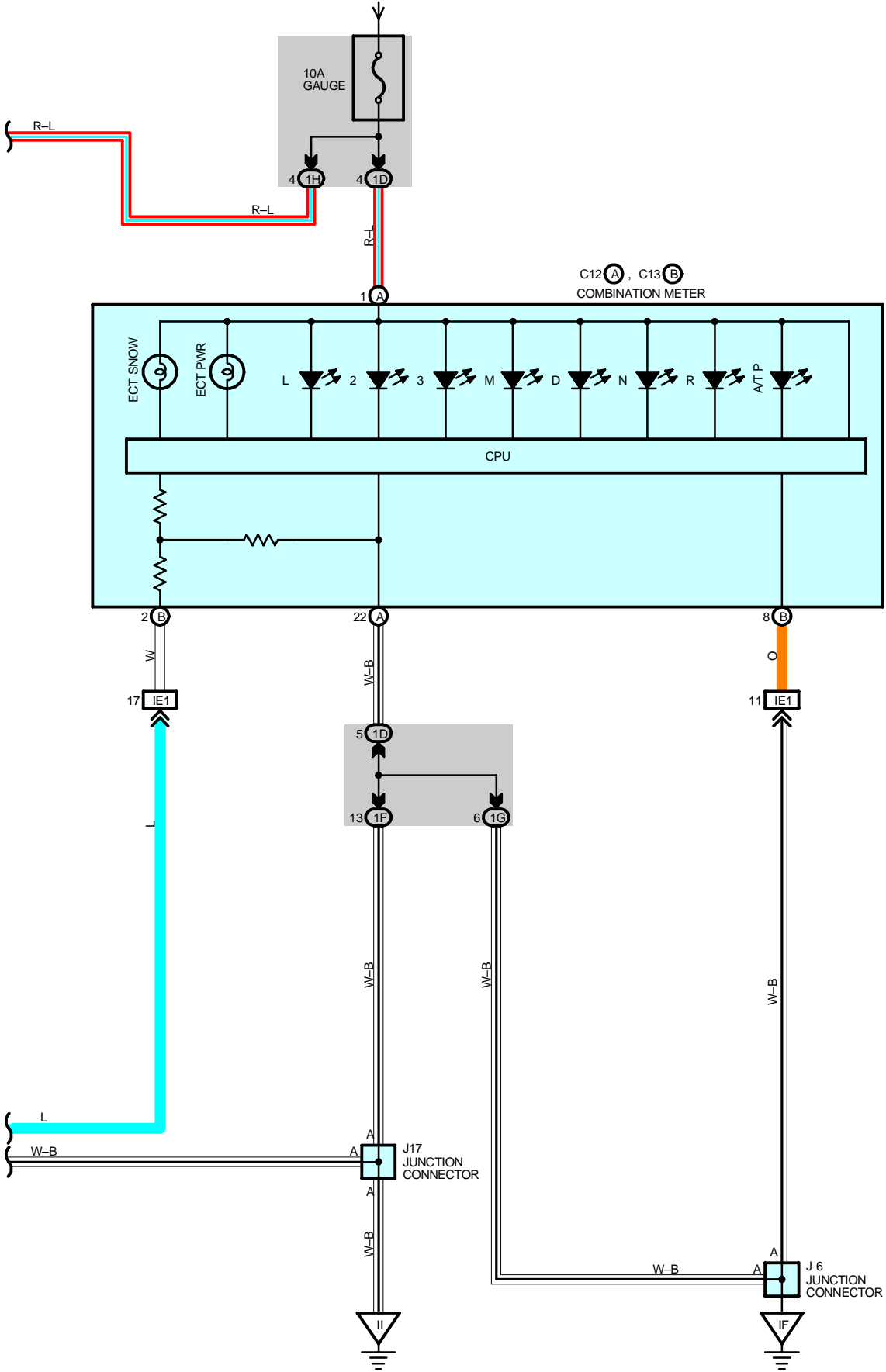

AND A/T INDICATOR (1UZ-FE)

SYSTEM OUTLINE

Previous automatic transmissions have selected each gear shift using mechanically controlled throttle hydraulic pressure, governor hydraulic pressure and lock-up hydraulic pressure. The electronically controlled transmission, however, electrically controls the line pressure, throttle pressure, lock-up pressure and accumulator pressure etc. through the solenoid valve. The electronically controlled transmission is a system which precisely controls gear shift timing and lock-up timing in response to the vehicle's driving conditions and the engine condition detected by various sensors. It makes smooth driving possible by shift selection for each gear which is the most appropriate to the driving conditions at that time, and by preventing downing, squat and gear shift shock when starting off.

1. GEAR SHIFT OPERATION

When driving, the engine warm up condition is input as a signal to TERMINAL THW of the engine control module from the engine coolant temp. sensor and the vehicle speed signal from vehicle speed sensor is input to TERMINAL SP2+ of the engine control module. At the same time, the throttle valve opening signal from the throttle position sensor is input to TERMINALS VTA and VTA2 of the engine control module as throttle angle signal.

Based on these signals, the engine control module selects the best shift position for the driving conditions and sends current to the electronically controlled transmission solenoid.

2. LOCK-UP OPERATION

When the engine control module decides based on each signal that the lock-up condition has been met, the current flows through TERMINAL SLU+ of the engine control module to TERMINAL 4 of the electronically controlled transmission solenoid to TERMINAL 10 to TERMINAL SLU- of the engine control module to GROUND.

3. STOP LIGHT SW CIRCUIT

If the brake pedal is depressed (Stop light SW on) when driving in lock-up condition, a signal is input to TERMINAL STP of the engine control module. The engine control module operates and cuts the current to the solenoid to release lock-up.

4. ELECTRONICALLY CONTROLLED TRANSMISSION PATTERN SELECT SW CIRCUIT

When the electronically controlled transmission pattern select SW is switched to PWR, a signal is input to TERMINAL PWR of the body ECU No.1, and control signals are distributed to the engine control module through communication control of the body ECU. This enables shift-up and shift-down at a higher speed range.

5. E-SHIFT SYSTEM

When the shift lever is set to the M position, the shift range can be switched with the UP or DOWN switch on the steering. (This limits to the maximum gear step and enables automatic shift-up and shift-down within the allowable range.)

SERVICE HINTS

E1 ELECTRONICALLY CONTROLLED TRANSMISSION SOLENOID

2-8 : 5.1-5.5 Ω

3-9 : 3.5-3.9 Ω

4-10 : 5.1-5.5 Ω

5, 6, 11, 12-GROUND : 11-15 Ω

E12 ELECTRONICALLY CONTROLLED TRANSMISSION PATTERN SELECT SW

7-3 : Closed with select SW at PWR position

1-3 : Only closed with select SW at SNOW position

V1 VEHICLE SPEED SENSOR (ELECTRONICALLY CONTROLLED TRANSMISSION)

1-2 : 560-680 Ω

O1 O/D DIRECT CLUTCH SPEED SENSOR

1-2 : 560-680 Ω

E3 (B), E5 (D), E6 (E) ENGINE CONTROL MODULE

BATT-E1 : Always approx. 12 volts

+B-E1 : Approx. 12 volts with ignition SW ON or ST position

+B1-E1 : Approx. 12 volts with ignition SW ON or ST position

MREL-E1 : Approx. 12 volts with ignition SW ON or ST position

STA-E1 : Approx. 12 volts with ignition SW ST position and shift lever other than P or N position

P1 A/T INDICATOR LIGHT SW [PARK / NEUTRAL POSITION SW]

4-7 : Closed with shift lever in P position

4-8 : Closed with shift lever in R position

4-10 : Closed with shift lever in N position

4-9 : Closed with shift lever in D position or M position

4-2 : Closed with shift lever in 3 position

4-3 : Closed with shift lever in 2 position or L position

ELECTRONICALLY CONTROLLED TRANSMISSION

○ : PARTS LOCATION

Code		See Page	Code		See Page	Code		See Page
A10		36 (1UZ-FE)	E6	E	36 (1UZ-FE)	J11		41
A13		40	E7	F	36 (1UZ-FE)	J14		41
B5	A	40	E8		36 (1UZ-FE)	J17		41
C12	A	40	E12		40	M3		41
C13	B	40	J1		37 (1UZ-FE)	O1		37 (1UZ-FE)
C16		40	J2		37 (1UZ-FE)	P1		37 (1UZ-FE)
D1		36 (1UZ-FE)	J3	A	37 (1UZ-FE)	S4		41
E1		36 (1UZ-FE)	J4	B	37 (1UZ-FE)	S11		41
E2	A	36 (1UZ-FE)	J5		37 (1UZ-FE)	T3		37 (1UZ-FE)
E3	B	36 (1UZ-FE)	J6		41	T5		41
E4	C	36 (1UZ-FE)	J7		41	V1		37 (1UZ-FE)
E5	D	36 (1UZ-FE)	J9		41			

○ : RELAY BLOCKS

Code	See Page	Relay Blocks (Relay Block Location)
1	22	Engine Room No.1 R/B (Engine Compartment Right)

○ : JUNCTION BLOCK AND WIRE HARNESS CONNECTOR

Code	See Page	Junction Block and Wire Harness (Connector Location)
1D	26	Instrument Panel Wire and Driver Side J/B (Left Kick Panel)
1F	26	Cowl Wire and Driver Side J/B (Left Kick Panel)
1G	27	
1H		

□ : CONNECTOR JOINING WIRE HARNESS AND WIRE HARNESS

Code	See Page	Joining Wire Harness and Wire Harness (Connector Location)
EA1	46 (1UZ-FE)	Engine Wire and Cowl Wire (Inside of the ECU Box)
EA2		
EA3		
EA4		
IA2	50	Engine Room Main Wire and Cowl Wire (Near the Driver Side J/B)
ID1	50	Cowl Wire and Cowl Wire (Left Side of the Instrument Panel Reinforcement)
IE1	50	Instrument Panel Wire and Cowl Wire (Left Side of the Steering Column)
II1	52	Engine Room Main Wire and Cowl Wire (Near the Passenger Side R/B)
II4		
IJ1	52	Instrument Panel Wire and Cowl Wire (Left Side of the Blower Unit)

▽ : GROUND POINTS

Code	See Page	Ground Points Location
EB	46 (1UZ-FE)	Left Fender
EC	46 (1UZ-FE)	RH Bank of the Cylinder Head
ED	46 (1UZ-FE)	LH Bank of the Cylinder Head
EE	46 (1UZ-FE)	Under the ABS & TRAC & VSC Actuator
IF	50	Left Kick Panel
II	50	Right Side of the Cowl Panel

○ : SPLICE POINTS

Code	See Page	Wire Harness with Splice Points	Code	See Page	Wire Harness with Splice Points
E1	46 (1UZ-FE)	Engine Wire	E4	46 (1UZ-FE)	Cowl Wire
E2					

AND A/T INDICATOR (1UZ-FE)

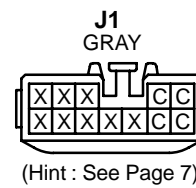
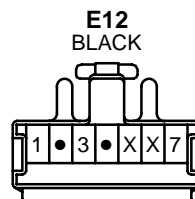
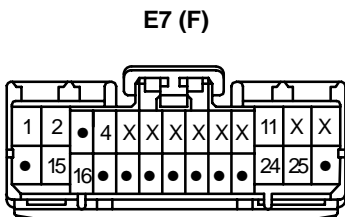
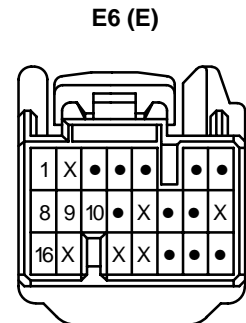
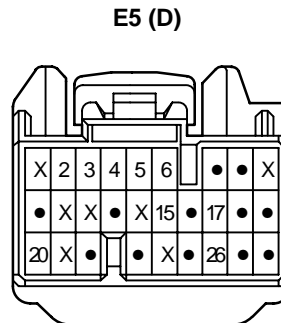
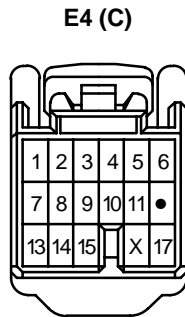
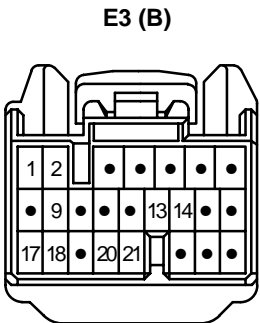
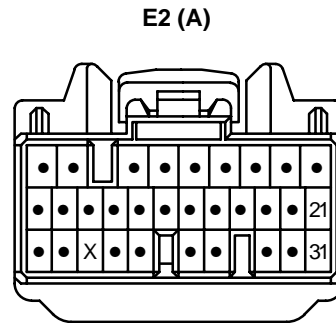
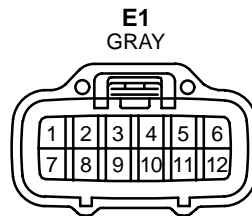
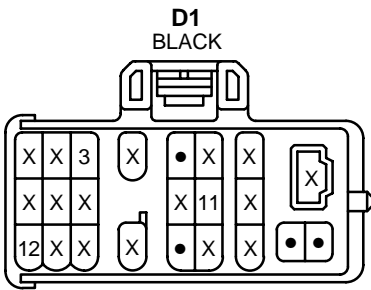
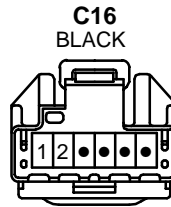
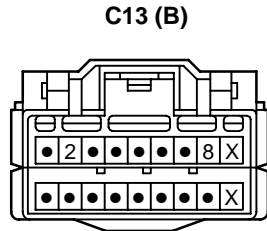
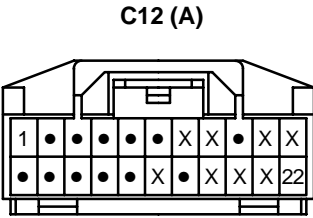
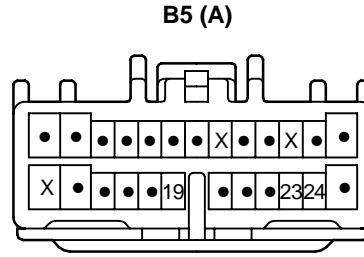
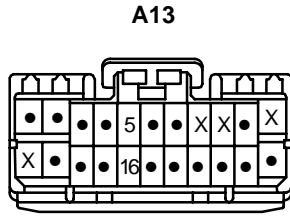

ELECTRONICALLY CONTROLLED TRANSMISSION AND A/T INDICATOR (1UZ-FE)

J2
ORANGE

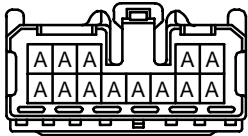

(Hint : See Page 7)

J3 (A)

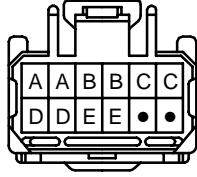

(Hint : See Page 7)

J4 (B)

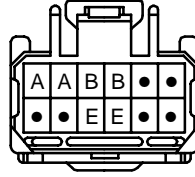

(Hint : See Page 7)

J5
BLUE



(Hint : See Page 7)

J6

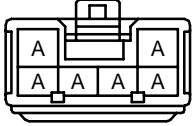

(Hint : See Page 7)

J7
GRAY

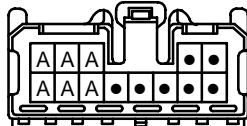

(Hint : See Page 7)

J9

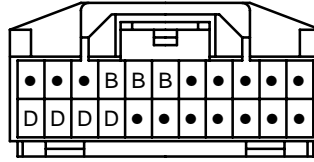

(Hint : See Page 7)

J11
GRAY

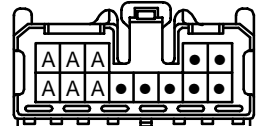

(Hint : See Page 7)

J14

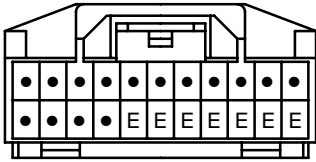

(Hint : See Page 7)

J17



(Hint : See Page 7)

M3
BLUE

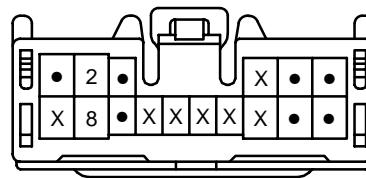

O1
BLACK

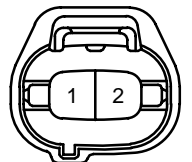

P1
GRAY

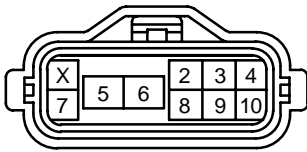

S4

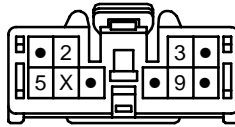

S11
BLUE

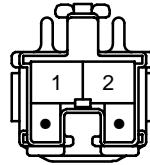

T3
GRAY



T5
GRAY

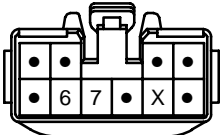

V1
BLACK

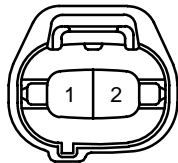

ELECTRONICALLY CONTROLLED TRANSMISSION

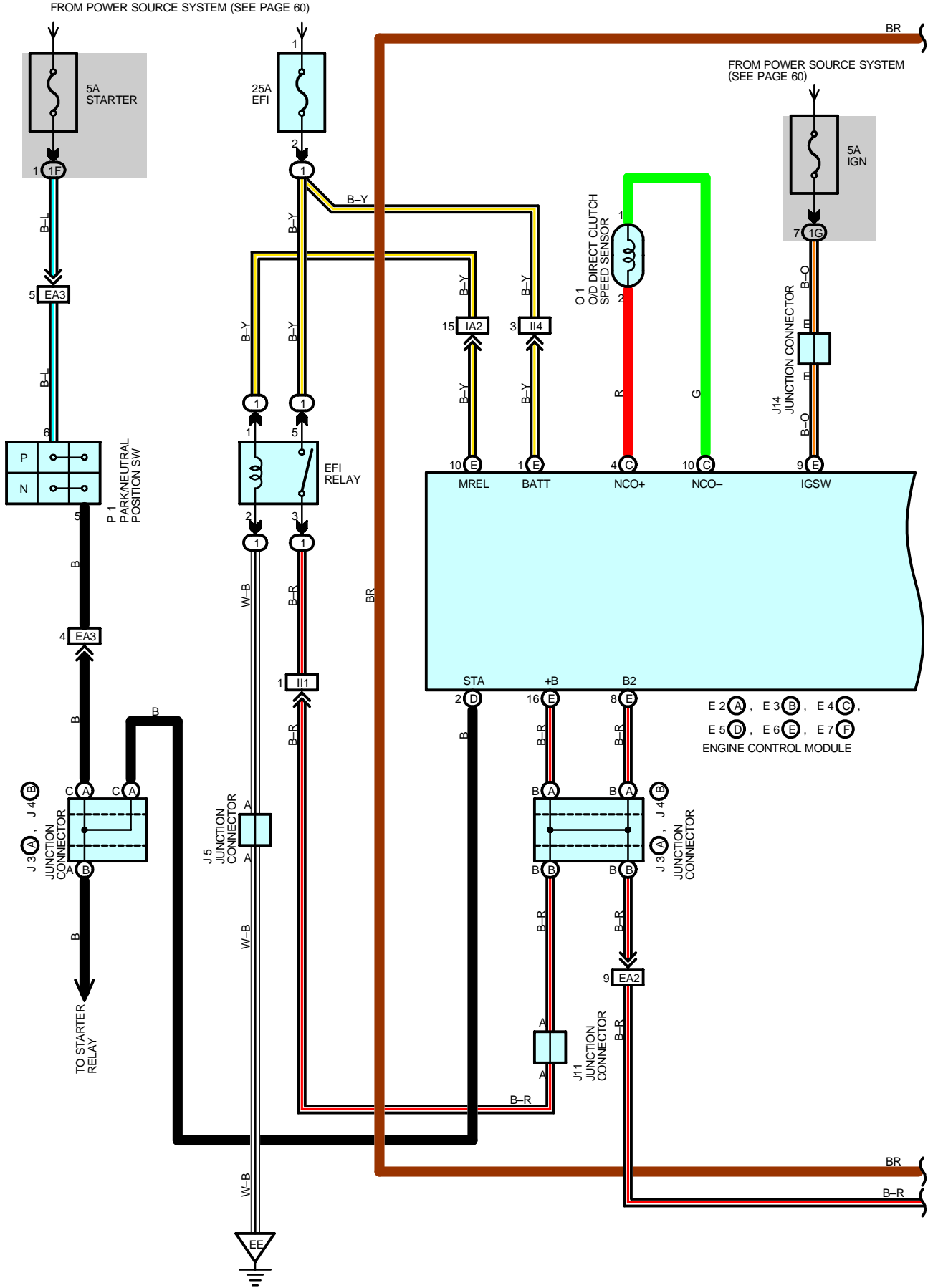

AND A/T INDICATOR (2JZ-GE)

FROM POWER SOURCE SYSTEM (SEE PAGE 60)

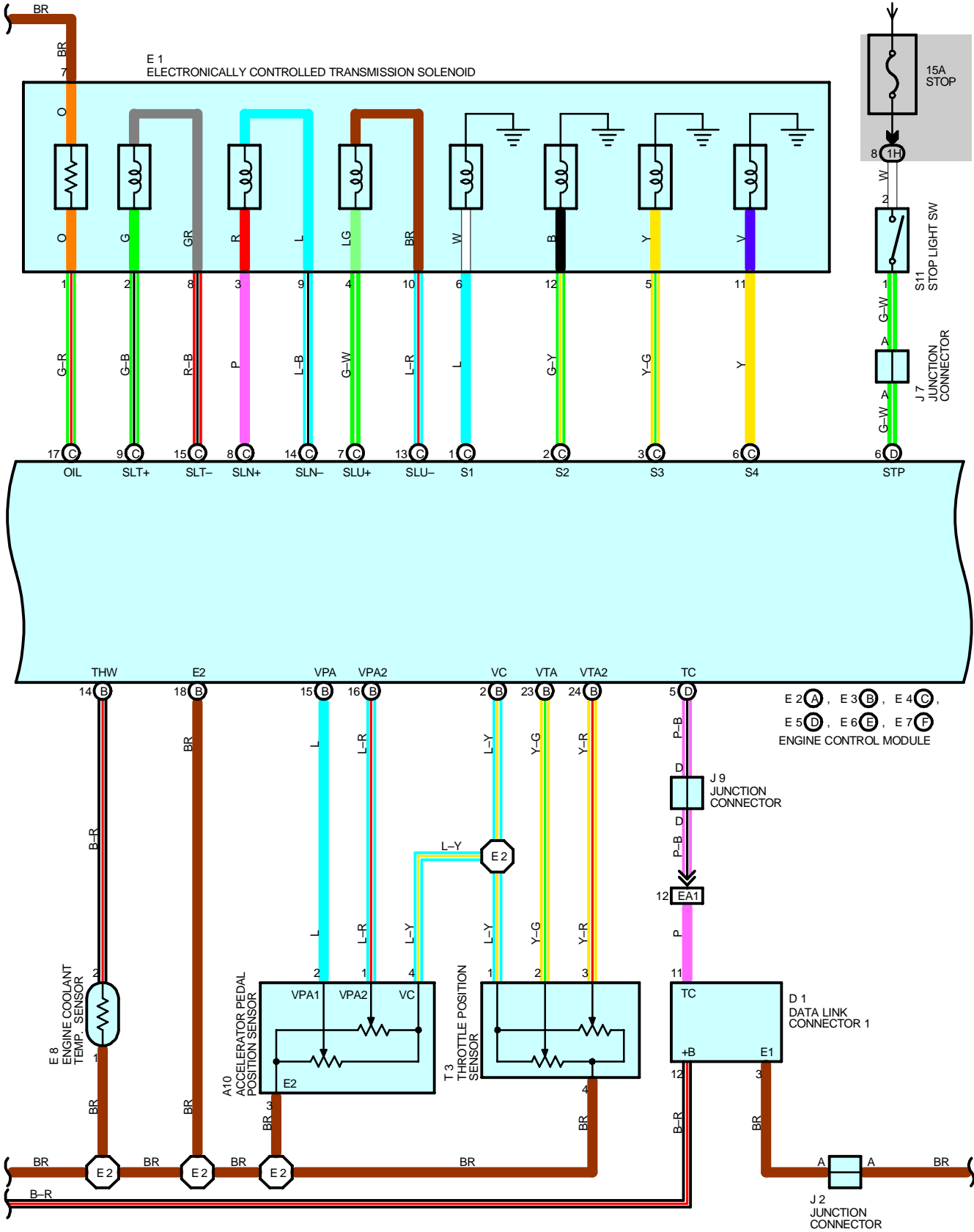

ELECTRONICALLY CONTROLLED TRANSMISSION

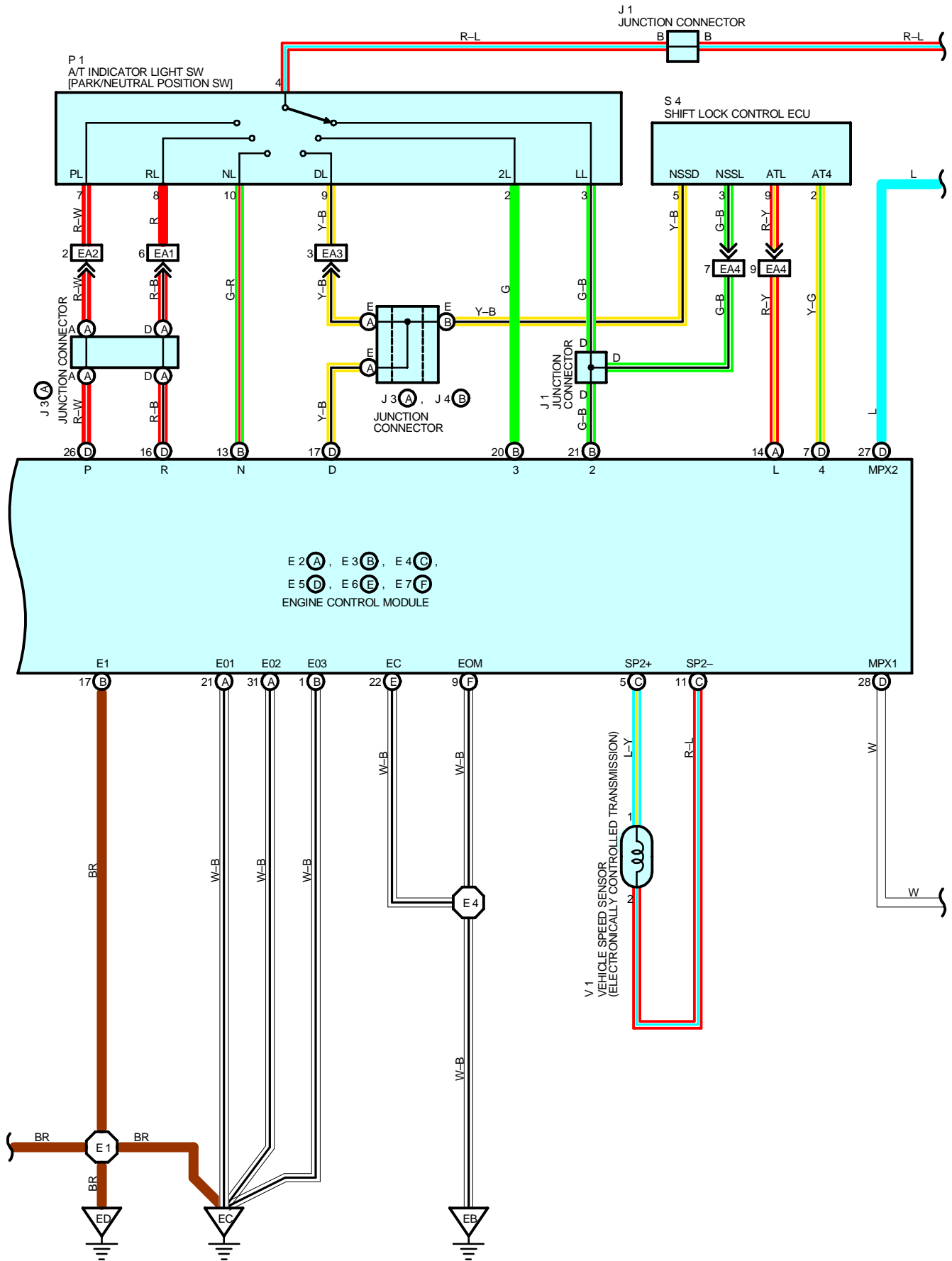

AND A/T INDICATOR (2JZ-GE)

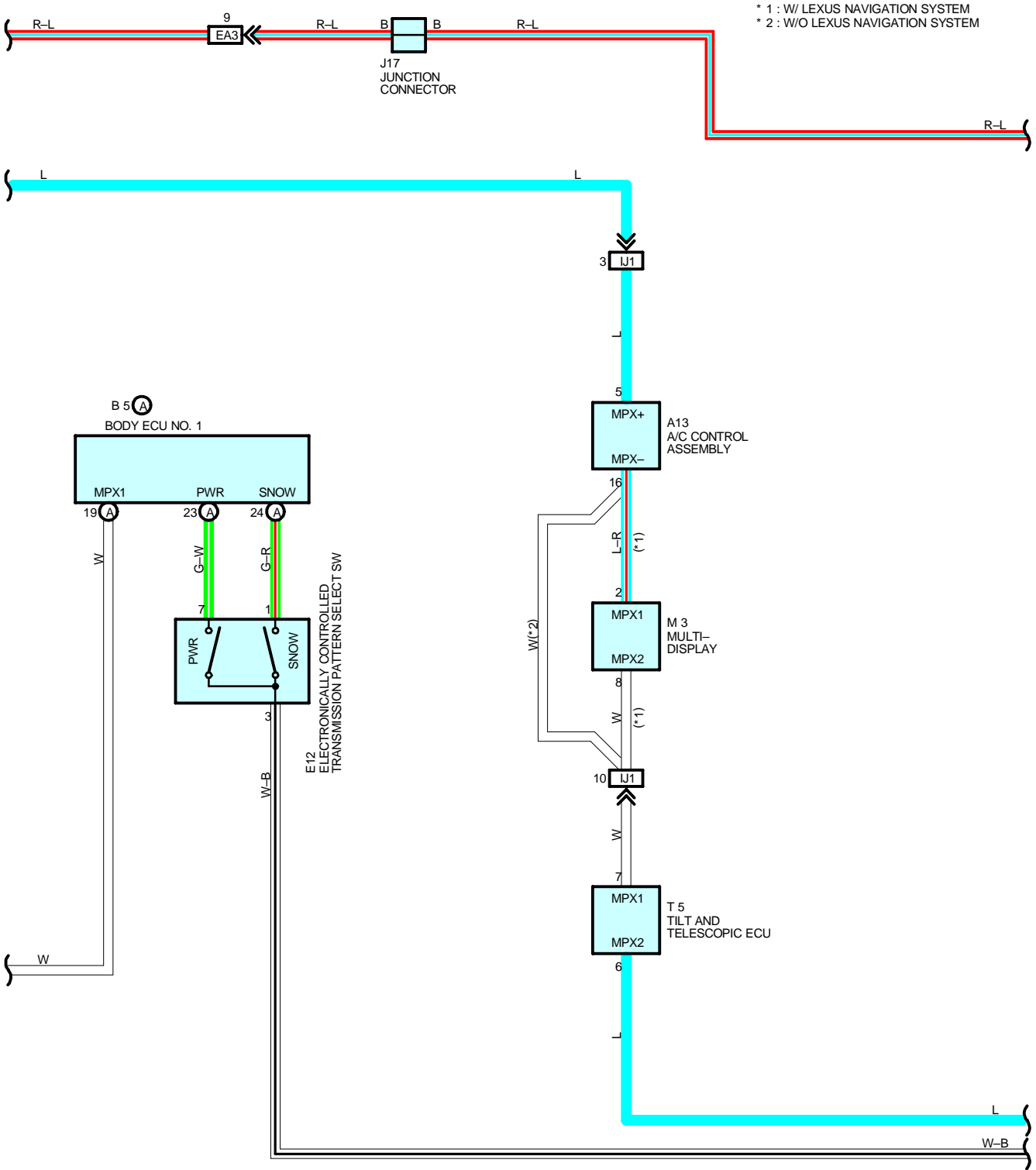

ELECTRONICALLY CONTROLLED TRANSMISSION

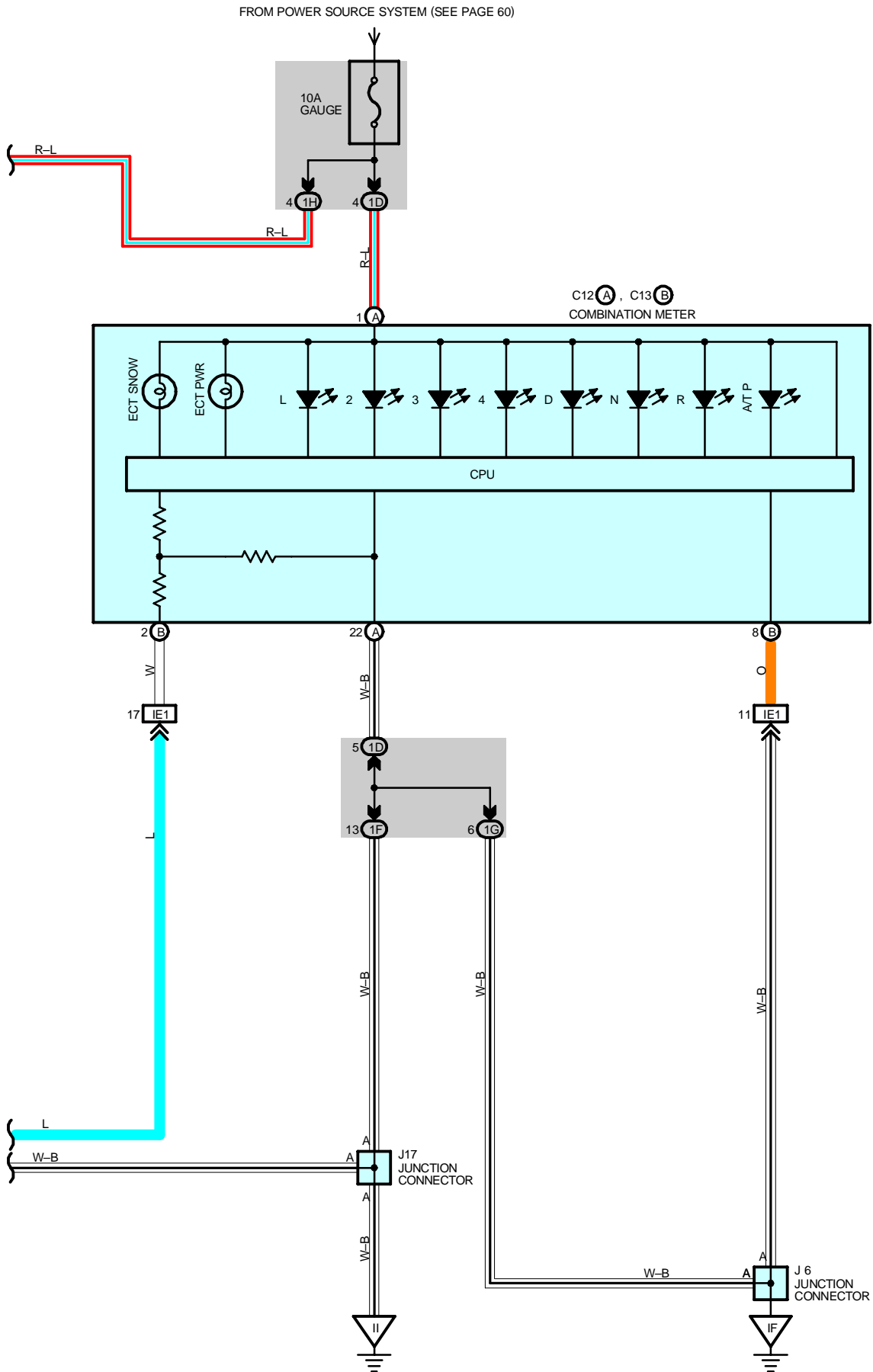

AND A/T INDICATOR (2JZ-GE)

SYSTEM OUTLINE

Previous automatic transmissions have selected each gear shift using mechanically controlled throttle hydraulic pressure, governor hydraulic pressure and lock-up hydraulic pressure. The electronically controlled transmission, however, electrically controls the line pressure, throttle pressure, lock-up pressure and accumulator pressure etc. through the solenoid valve. The electronically controlled transmission is a system which precisely controls gear shift timing and lock-up timing in response to the vehicle's driving conditions and the engine condition detected by various sensors. It makes smooth driving possible by shift selection for each gear which is the most appropriate to the driving conditions at that time, and by preventing downing, squat and gear shift shock when starting off.

1. GEAR SHIFT OPERATION

When driving, the engine warm up condition is input as a signal to TERMINAL THW of the engine control module from the engine coolant temp. sensor and the vehicle speed signal from vehicle speed sensor is input to TERMINAL SP2+ of the engine control module. At the same time, the throttle valve opening signal from the throttle position sensor is input to TERMINALS VTA and VTA2 of the engine control module as throttle angle signal.

Based on these signals, the engine control module selects the best shift position for the driving conditions and sends current to the electronically controlled transmission solenoid.

2. LOCK-UP OPERATION

When the engine control module decides based on each signal that the lock-up condition has been met, the current flows through TERMINAL SLU+ of the engine control module to TERMINAL 4 of the electronically controlled transmission solenoid to TERMINAL 10 to TERMINAL SLU- of the engine control module to GROUND.

3. STOP LIGHT SW CIRCUIT

If the brake pedal is depressed (Stop light SW on) when driving in lock-up condition, a signal is input to TERMINAL STP of the engine control module. The engine control module operates and cuts the current to the solenoid to release lock-up.

4. ELECTRONICALLY CONTROLLED TRANSMISSION PATTERN SELECT SW CIRCUIT

When the electronically controlled transmission pattern select SW is switched to PWR, a signal is input to TERMINAL PWR of the body ECU No.1, and control signals are distributed to the engine control module through communication control of the body ECU. This enables shift-up and shift-down at a higher speed range.

SERVICE HINTS

E1 ELECTRONICALLY CONTROLLED TRANSMISSION SOLENOID

2-8 : 5.1-5.5 Ω

3-9 : 3.5-3.9 Ω

4-10 : 5.1-5.5 Ω

5, 6, 11, 12-GROUND : 11-15 Ω

E12 ELECTRONICALLY CONTROLLED TRANSMISSION PATTERN SELECT SW

7-3 : Closed with select SW at **PWR** position

1-3 : Only closed with select SW at **SNOW** position

V1 VEHICLE SPEED SENSOR (ELECTRONICALLY CONTROLLED TRANSMISSION)

1-2 : 560-680 Ω

O1 O/D DIRECT CLUTCH SPEED SENSOR

1-2 : 560-680 Ω

E3 (B), E5 (D), E6 (E) ENGINE CONTROL MODULE

BATT-E1 : Always approx. 12 volts

+B-E1 : Approx. 12 volts with ignition SW **ON** or **ST** position

B2-E1 : Approx. 12 volts with ignition SW **ON** or **ST** position

MREL-E1 : Approx. 12 volts with ignition SW **ON** or **ST** position

STA-E1 : Approx. 12 volts with ignition SW **ST** position and shift lever other than **P** or **N** position

P1 A/T INDICATOR LIGHT SW [PARK / NEUTRAL POSITION SW]

4-7 : Closed with shift lever in **P** position

4-8 : Closed with shift lever in **R** position

4-10 : Closed with shift lever in **N** position

4-9 : Closed with shift lever in **D** position or **4** position

4-2 : Closed with shift lever in **3** position

4-3 : Closed with shift lever in **2** position or **L** position

ELECTRONICALLY CONTROLLED TRANSMISSION

○ : PARTS LOCATION

Code	See Page	Code	See Page	Code	See Page	
A10	38 (2JZ-GE)	E7	F	38 (2JZ-GE)	J14	41
A13	40	E8		38 (2JZ-GE)	J17	41
B5	A	40	E12	40	M3	41
C12	A	40	J1	39 (2JZ-GE)	O1	39 (2JZ-GE)
C13	B	40	J2	39 (2JZ-GE)	P1	39 (2JZ-GE)
D1	38 (2JZ-GE)	J3	A	39 (2JZ-GE)	S4	41
E1	38 (2JZ-GE)	J4	B	39 (2JZ-GE)	S11	41
E2	A	38 (2JZ-GE)	J5	39 (2JZ-GE)	T3	39 (2JZ-GE)
E3	B	38 (2JZ-GE)	J6	41	T5	41
E4	C	38 (2JZ-GE)	J7	41	V1	39 (2JZ-GE)
E5	D	38 (2JZ-GE)	J9	41		
E6	E	38 (2JZ-GE)	J11	41		

○ : RELAY BLOCKS

Code	See Page	Relay Blocks (Relay Block Location)
1	22	Engine Room No.1 R/B (Engine Compartment Right)

○ : JUNCTION BLOCK AND WIRE HARNESS CONNECTOR

Code	See Page	Junction Block and Wire Harness (Connector Location)
1D	26	Instrument Panel Wire and Driver Side J/B (Left Kick Panel)
1F	26	Cowl Wire and Driver Side J/B (Left Kick Panel)
1G	27	
1H		

□ : CONNECTOR JOINING WIRE HARNESS AND WIRE HARNESS

Code	See Page	Joining Wire Harness and Wire Harness (Connector Location)
EA1	48 (2JZ-GE)	Engine Wire and Cowl Wire (Inside of the ECU Box)
EA2		
EA3		
EA4		
IA2	50	Engine Room Main Wire and Cowl Wire (Near the Driver Side J/B)
IE1	50	Instrument Panel Wire and Cowl Wire (Left Side of the Steering Column)
II1	52	Engine Room Main Wire and Cowl Wire (Near the Passenger Side R/B)
II4		
IJ1	52	Instrument Panel Wire and Cowl Wire (Left Side of the Blower Unit)

▽ : GROUND POINTS

Code	See Page	Ground Points Location
EB	48 (2JZ-GE)	Left Fender
EC	48 (2JZ-GE)	Front Side of the Intake Manifold
ED	48 (2JZ-GE)	Rear Side of the Intake Manifold
EE	48 (2JZ-GE)	Under the ABS & TRAC & VSC Actuator
IF	50	Left Kick Panel
II	50	Right Side of the Cowl Panel

○ : SPLICE POINTS

Code	See Page	Wire Harness with Splice Points	Code	See Page	Wire Harness with Splice Points
E1	48 (2JZ-GE)	Engine Wire	E4	48 (2JZ-GE)	Cowl Wire
E2					

AND A/T INDICATOR (2JZ-GE)

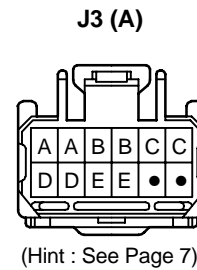
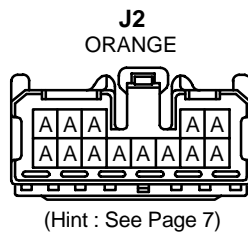
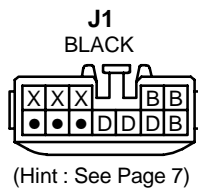
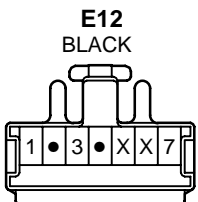
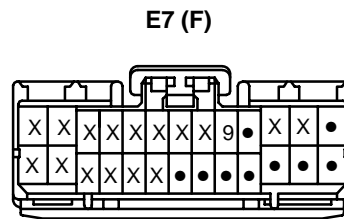
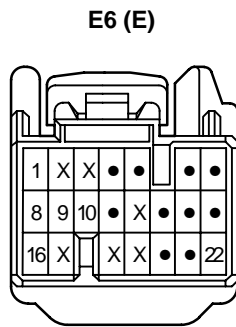
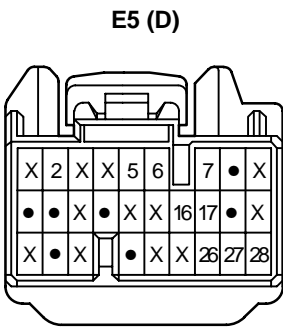
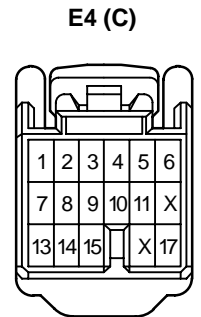
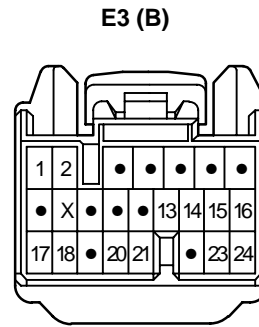
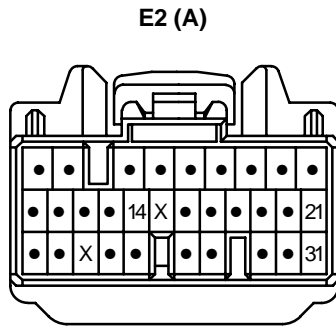
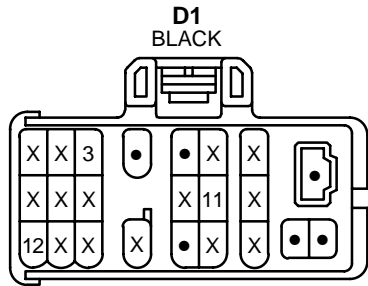
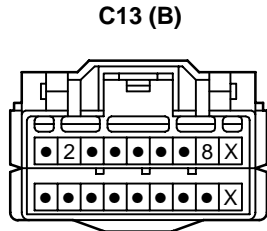
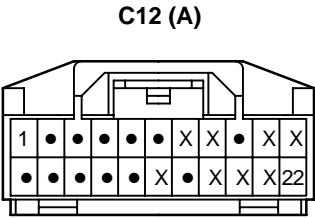
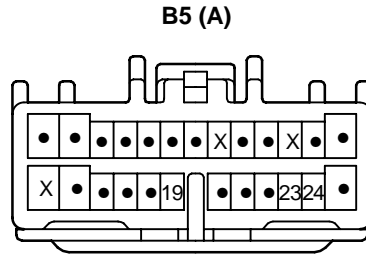
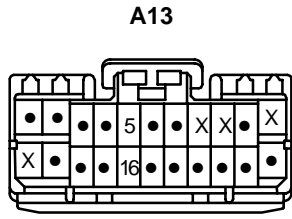

ELECTRONICALLY CONTROLLED TRANSMISSION AND A/T INDICATOR (2JZ-GE)

J4 (B)

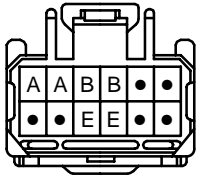

(Hint : See Page 7)

J5
BLUE

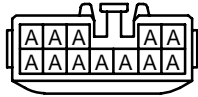

(Hint : See Page 7)

J6

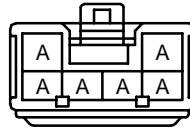

(Hint : See Page 7)

J7
GRAY

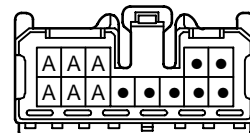

(Hint : See Page 7)

J9

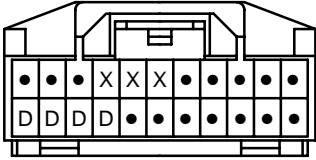

(Hint : See Page 7)

J11
GRAY

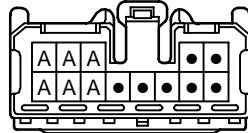

(Hint : See Page 7)

J14

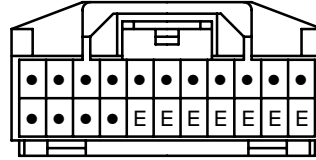

(Hint : See Page 7)

J17

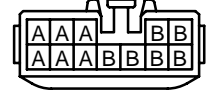

(Hint : See Page 7)

M3
BLUE

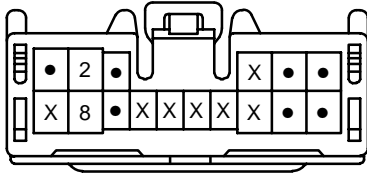

O1
BLACK

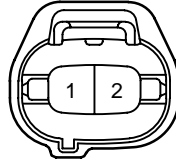

P1
GRAY

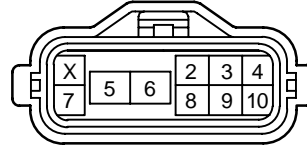

S4

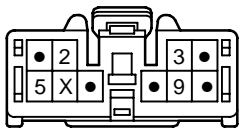

S11
BLUE

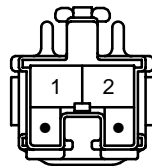

T3
BLACK



T5
GRAY

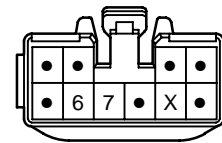

V1
BLACK

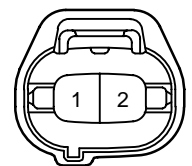

ENGINE CONTROL (1UZ-FE)

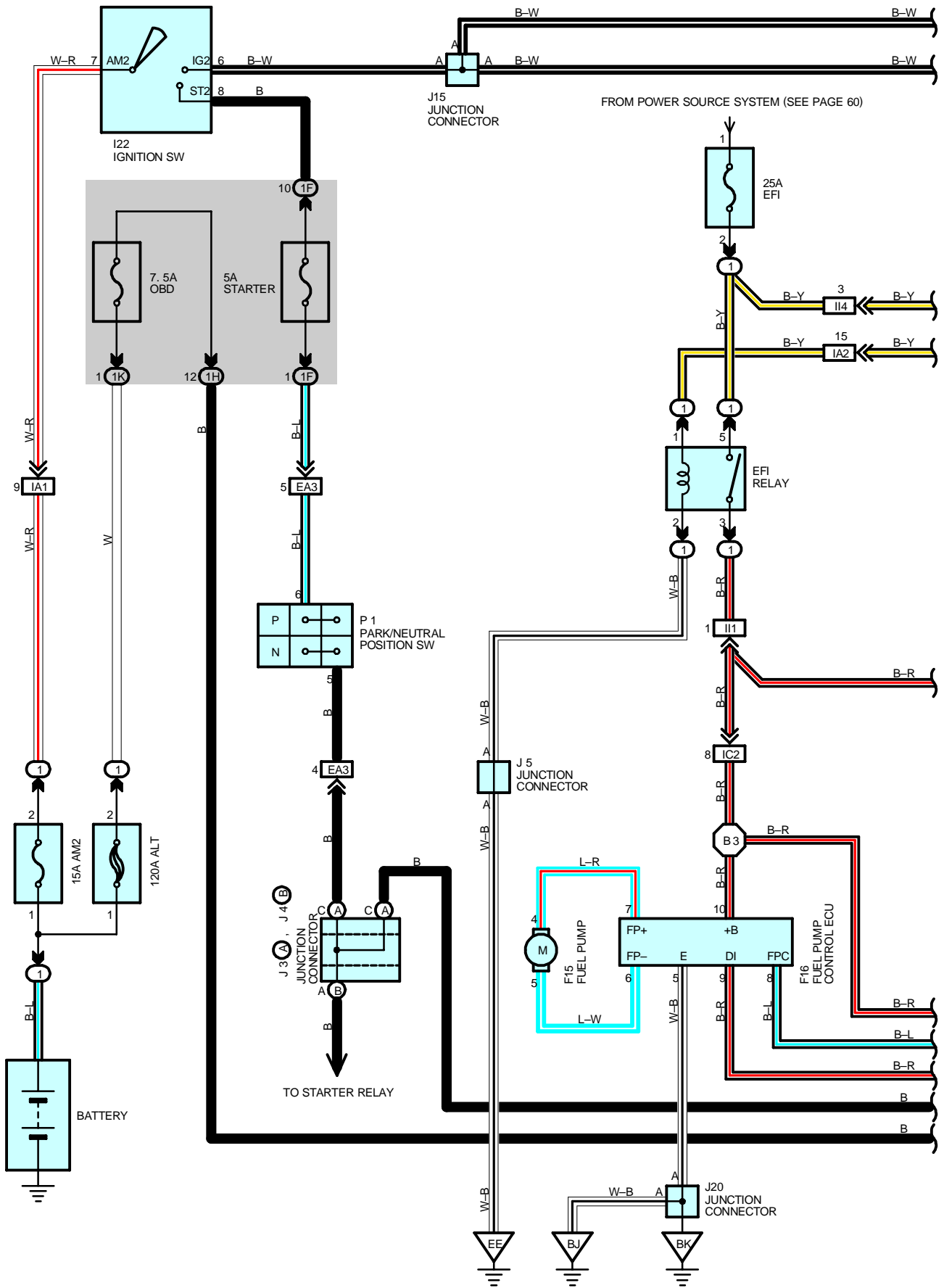

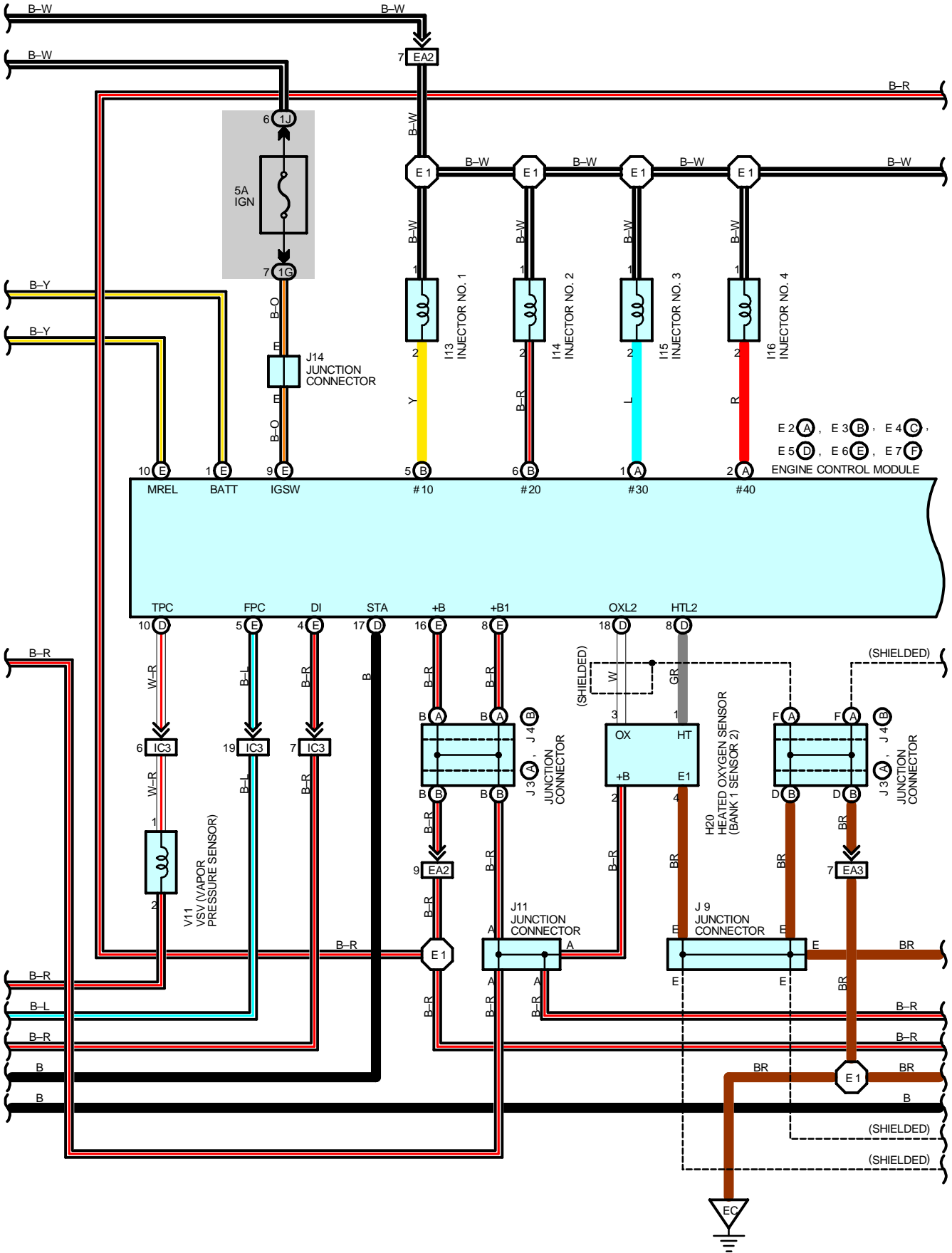

ENGINE CONTROL (1UZ-FE)

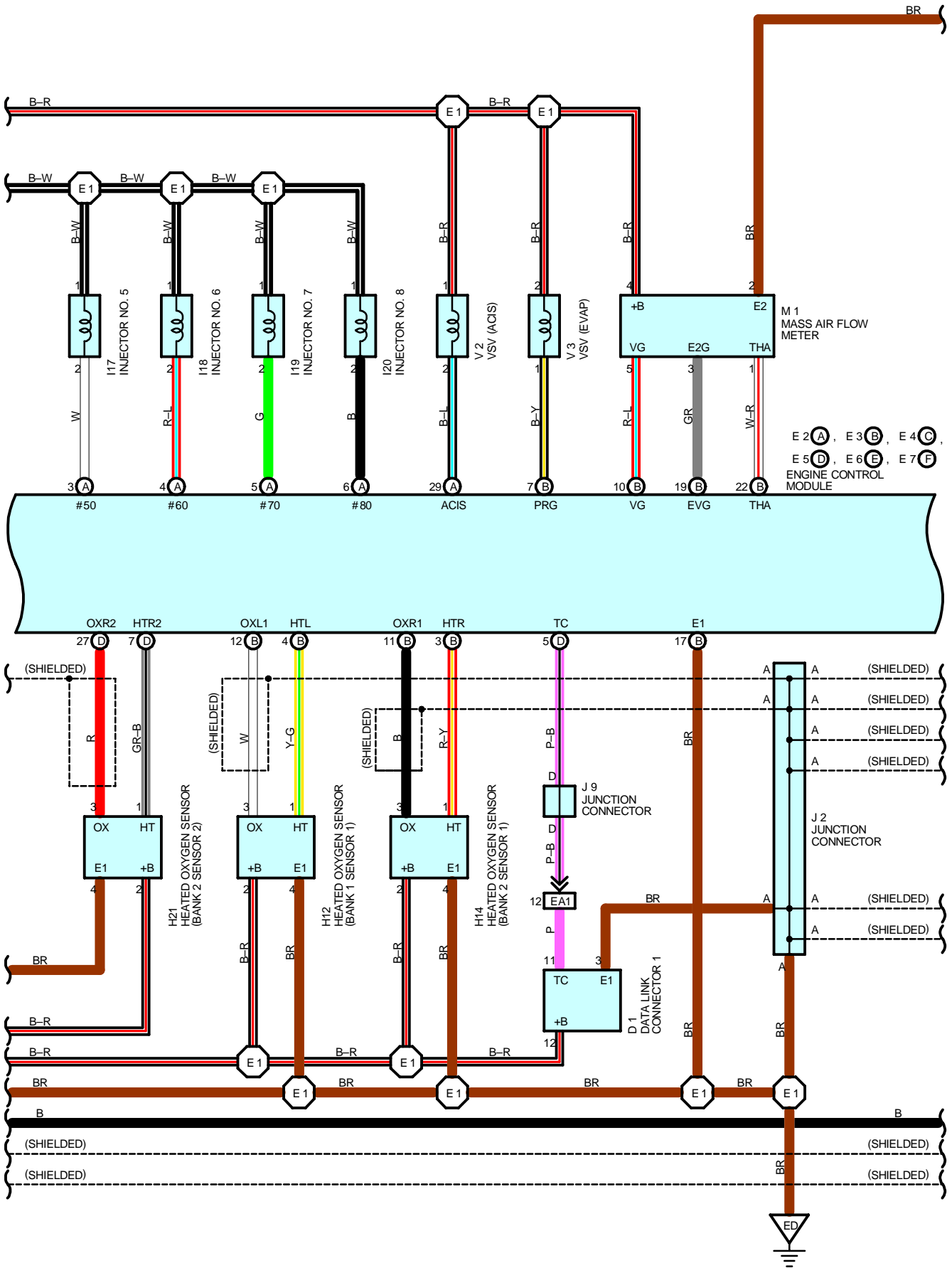

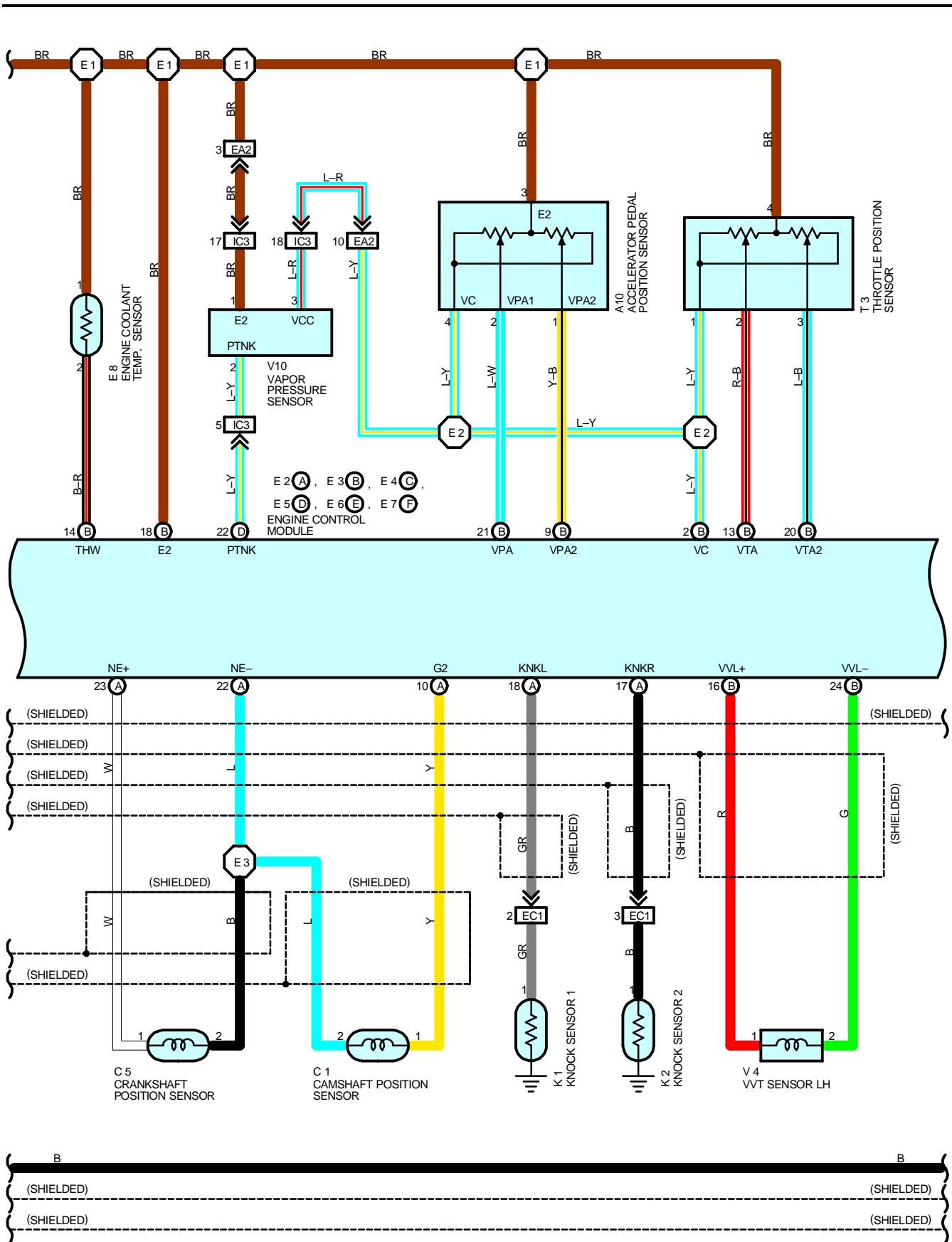

ENGINE CONTROL (1UZ-FE)

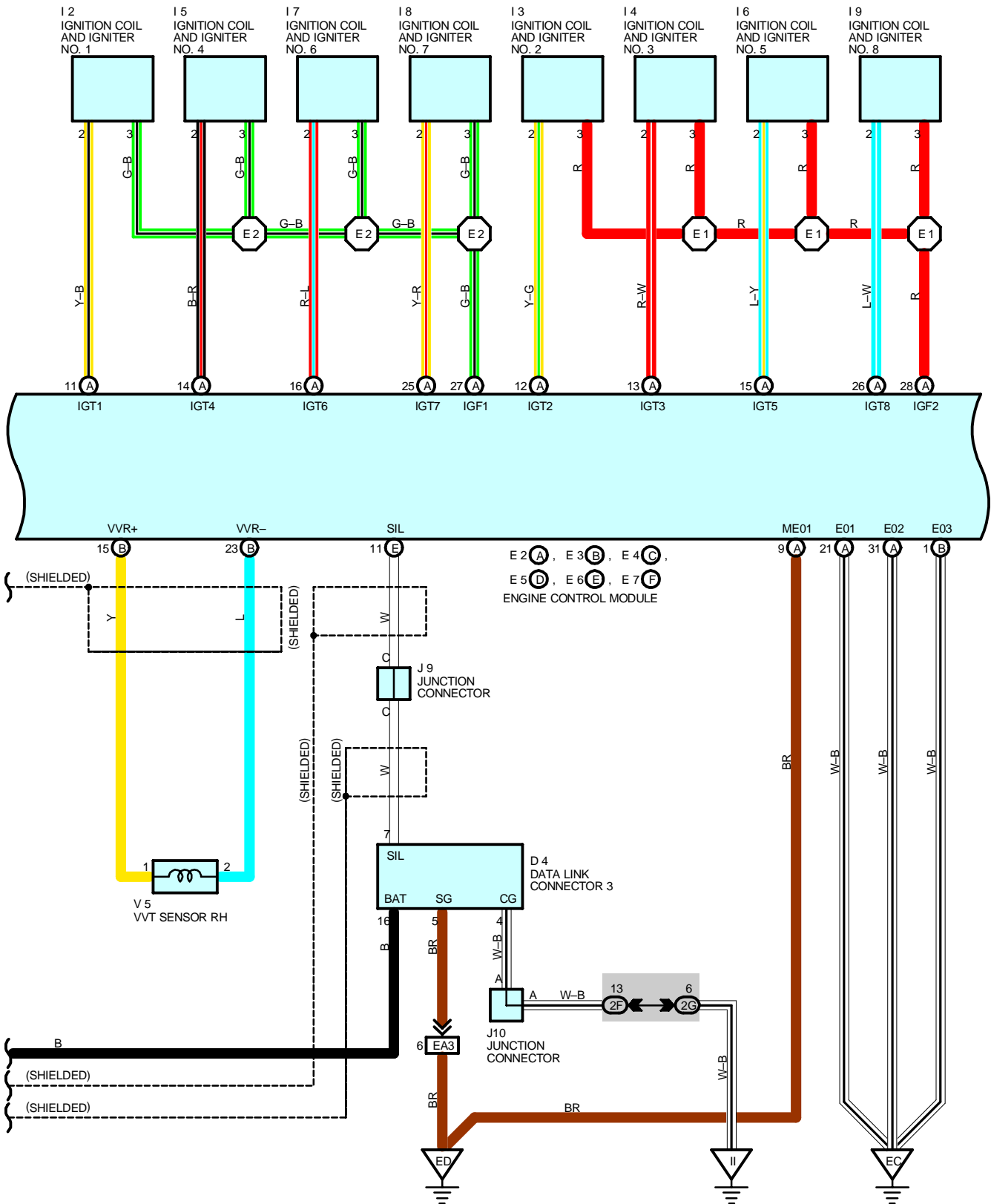

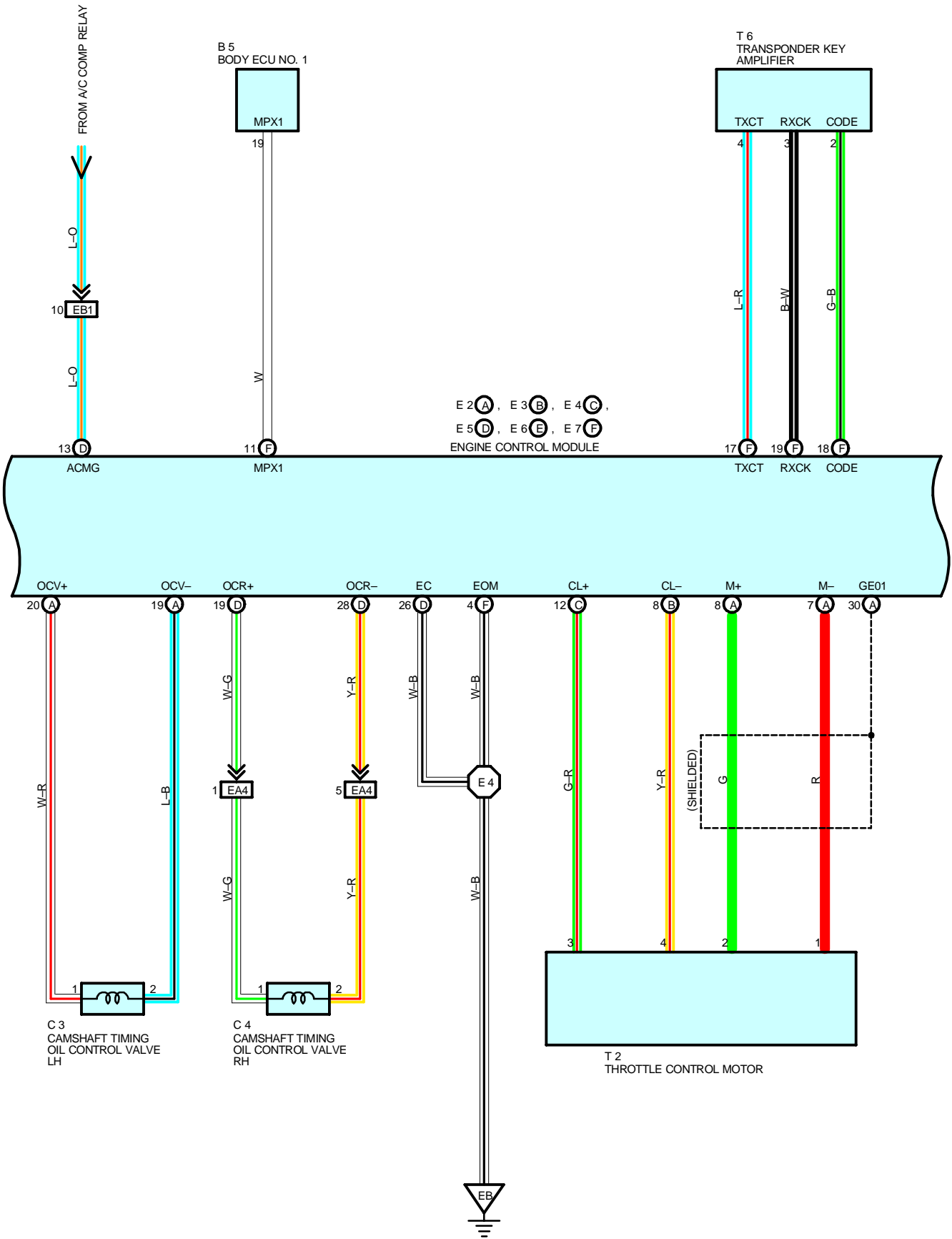

ENGINE CONTROL (1UZ-FE)

FROM POWER SOURCE SYSTEM (SEE PAGE 60)

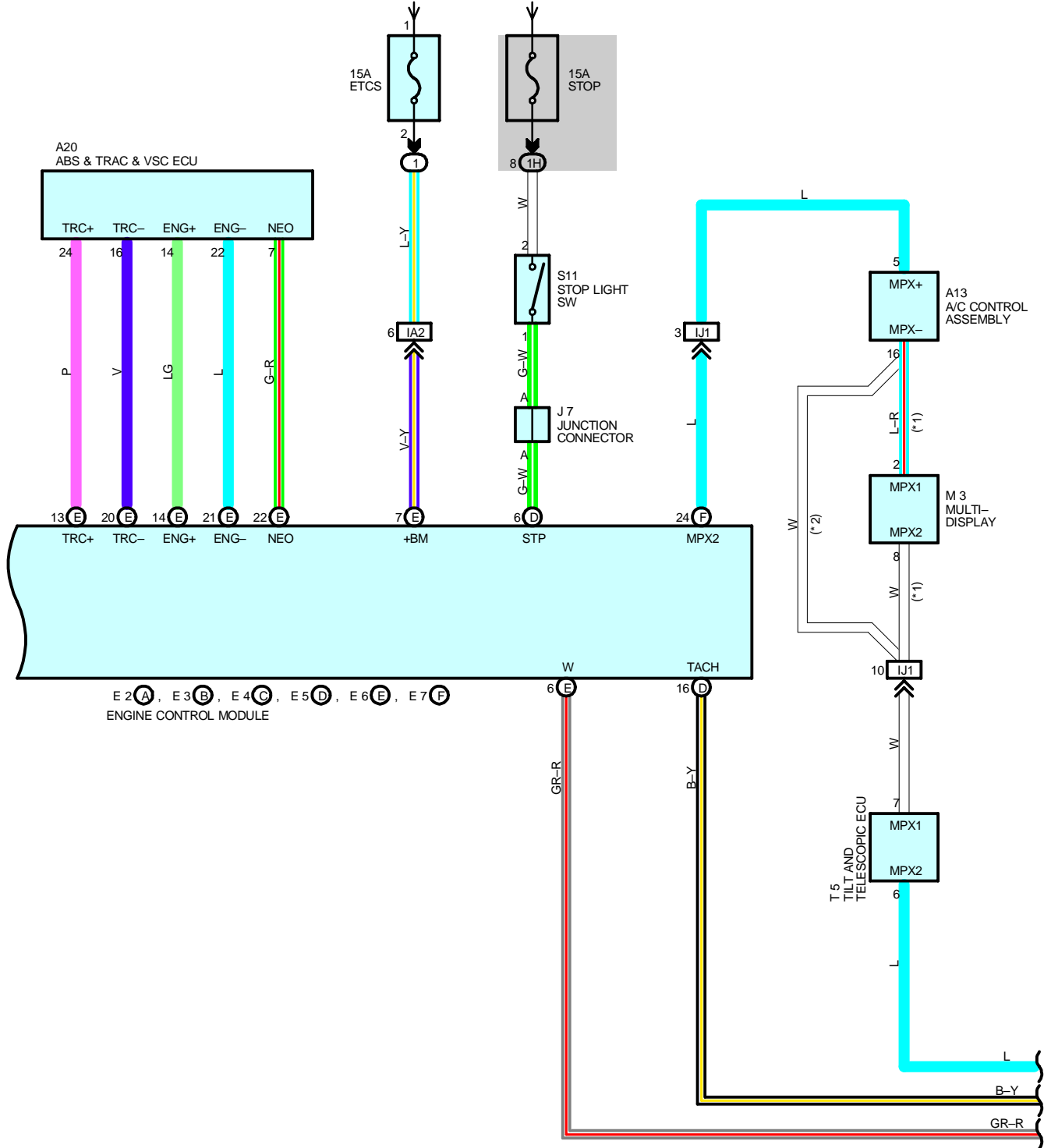

FROM POWER SOURCE SYSTEM (SEE PAGE 60)

- * 1 : W/ LEXUS NAVIGATION SYSTEM
- * 2 : W/O LEXUS NAVIGATION SYSTEM

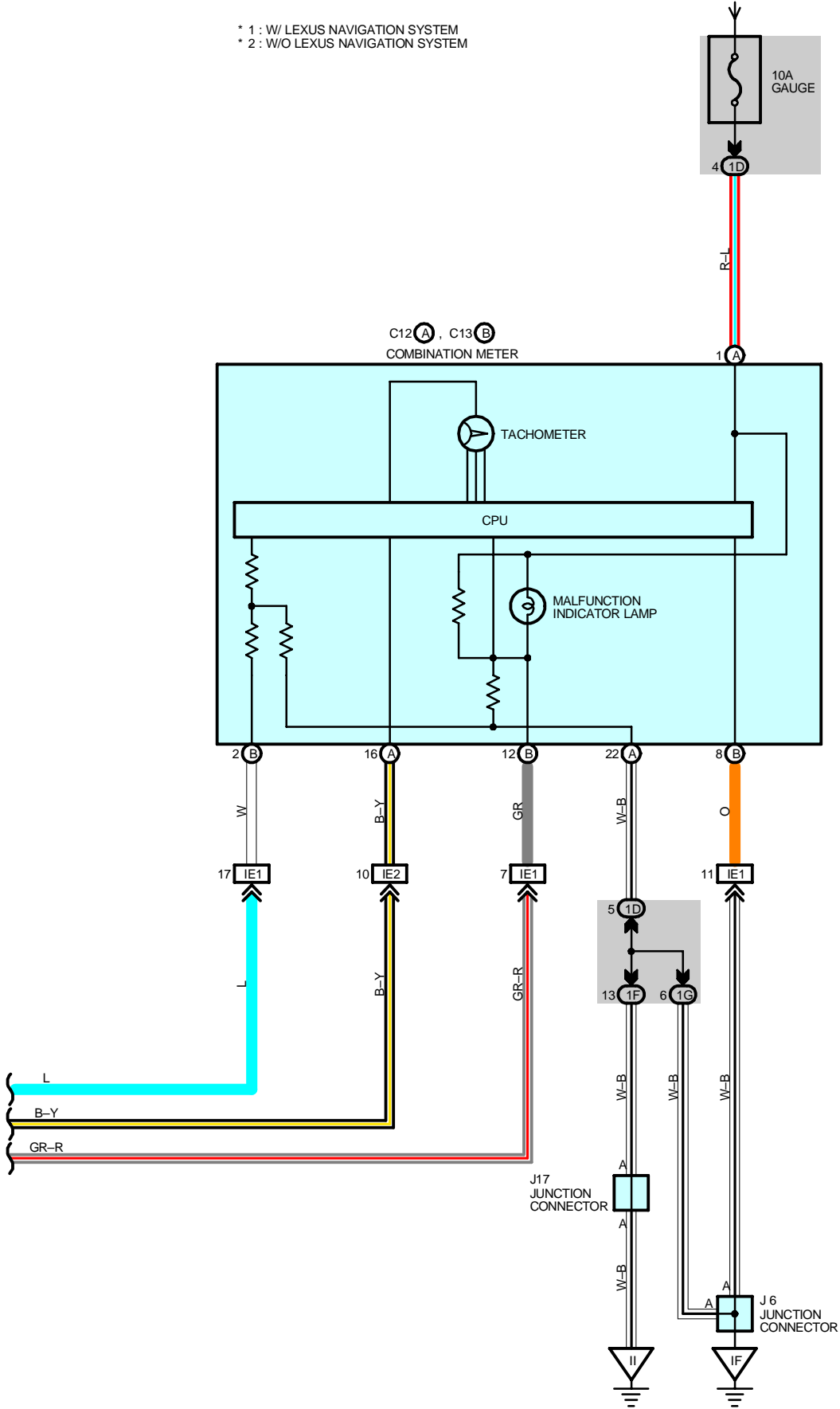

ENGINE CONTROL (1UZ-FE)

SYSTEM OUTLINE

This system utilizes an engine control module and maintains overall control of the engine, transmission and so on. An outline of the engine control is explained here.

1. INPUT SIGNALS

(1) Engine coolant temp. signal circuit

The engine coolant temp. sensor detects the engine coolant temp. and has a built-in thermistor with a resistance which varies according to the engine coolant temp. The engine coolant temp. is input into TERMINAL THW of the engine control module as a control signal.

(2) Intake air temp. signal circuit

The intake air temp. sensor is installed in the mass air flow meter and detects the intake air temp., which is input as a control signal to TERMINAL THA of the engine control module.

(3) Oxygen sensor signal circuit

The oxygen density in the exhaust emission is detected and is input as a control signal from the heated oxygen sensors (Bank 1 sensor 1, bank 2 sensor 1, bank 1 sensor 2 and bank 2 sensor 2) to TERMINALS OXL1, OXR1, OXL2 and OXR2 of the engine control module.

To stabilize detection performance by the heated oxygen sensors, the heated oxygen sensors are warmed. This heater is also controlled by the engine control module (HTL, HTR, HTL2 and HTR2).

(4) RPM signal circuit

Camshaft position is detected by the camshaft position sensor and its signal is input to TERMINAL G2 of the engine control module as a control signal. Also, the engine RPM is detected by the crankshaft position sensor installed in the cylinder block and the signal is input into TERMINAL NE+ of the engine control module as a control signal.

(5) Throttle signal circuit

The throttle position sensor detects the throttle valve opening angle as a control signal, which is input into TERMINALS VTA and VTA2 of the engine control module.

(6) Vehicle speed circuit

Signals detected by ABS speed sensors are input into the combination meter through ABS & TRAC & VSC ECU. Then it is delivered to the engine ECU through MPX communication.

(7) A/C SW signal circuit

The operating voltage of the A/C magnetic clutch is detected and the signal is input into TERMINAL ACMG of the engine control module as a control signal.

(8) Battery signal circuit

Voltage is constantly applied to TERMINAL BATT of the engine control module. With the ignition SW turned on, Voltage for engine control module start-up power supply is applied to TERMINALS +B and +B1 of the engine control module via the EFI relay.

The current flowing through the IGN fuse to TERMINAL IGSW of the engine control module.

Voltage is constantly applied to TERMINAL +BM of the engine control module.

(9) Intake air volume signal circuit

Intake air volume is detected by the mass air flow meter and the signal is input to TERMINAL VG of the engine control module as a control signal.

(10) Stop light SW signal circuit

The stop light SW is used to detect whether or not the vehicle is braking and the signal is input into TERMINAL STP of the engine control module as a control signal.

(11) Starter signal circuit

To confirm whether the engine is cranking, the voltage applied to the starter motor during cranking is detected and the signal is input into TERMINAL STA of the engine control module as a control signal.

(12) Engine knock signal circuit

Engine knocking is detected by knock sensor 1 and 2 and the signal is input into TERMINALS KNKL and KNKR as a control signal.

2. CONTROL SYSTEM

*** SFI system**

The SFI system monitors the engine condition through the signals input from each sensor (Input signals from (1) to (12) etc.) to the engine control module. The best fuel injection timing is decided based on this data and the program memorized by the engine control module, and the control signal is output to TERMINALS #10, #20, #30, #40, #50, #60, #70 and #80 of the engine control module to operate the injector (Inject the fuel). The sequential multiport fuel injection (Electronic fuel injection) system controls the fuel injection operation by the engine control module in response to the driving conditions.

*** ESA (Electronic Spark Advance) system**

The ESA system monitors the engine condition through the signals input to the engine control module from each sensor (Input signals from (1), (2), (4) to (12) etc.). The best ignition timing is decided according to this data and the memorized data in the engine control module, and the control signal is output to TERMINALS IGT1, IGT2, IGT3, IGT4, IGT5, IGT6, IGT7 and IGT8. This signal controls the igniter to provide the best ignition timing for the driving conditions.

*** Heated oxygen sensor heater control system**

The heated oxygen sensor heater control system turns the heater on when the intake air volume is low (Temp. of exhaust emissions is low), and warms up the heated oxygen sensors (Bank 1 sensor 1, bank 2 sensor 1, bank 1 sensor 2 and bank 2 sensor 2) to improve detection performance of the sensors.

The engine control module evaluates the signals from each sensor (Input signals from (1), (2), (4), (8) to (10) etc.), and outputs current to TERMINALS HTL, HTR, HTL2 and HTR2 to control the heater.

*** ACIS**

ACIS includes a valve in the bulkhead separating the surge tank into two parts. This valve is opened and closed in accordance with the driving conditions to control the intake manifold length in two stages for increased engine output in all ranges from low to high speeds.

The engine control module judges the engine speed by the signals ((4), (5)) from each sensor and outputs signals to the TERMINAL ACIS to control the VSV (ACIS).

*** Fuel pump control**

The engine control module outputs current to TERMINAL FPC and controls the fuel pump control ECU and fuel pump drive speed in response to driving conditions.

*** ETCS-i**

The ETCS-i controls the engine output at its optimal level corresponding to the opening of the accel. pedal under all driving conditions.

*** MPX**

The MPX communicates with the combination meter, A/C control assembly, as well as body ECU of the multiplex communication system

3. DIAGNOSIS SYSTEM

With the diagnosis system, when there is a malfunction in the engine control module signal system, the malfunctioning system is recorded in the memory. The malfunctioning system can be found by reading the code displayed by the malfunction indicator lamp.

4. FAIL-SAFE SYSTEM

When a malfunction has occurred in any system, if there is a possibility of engine trouble being caused by continued control based on the signals from that system, the fail-safe system either controls the system by using data (Standard values) recorded in the engine control module memory or else stops the engine.

ENGINE CONTROL (1UZ-FE)

SERVICE HINTS

EFI RELAY

5-3 : Closed with ignition SW at **ON** or **ST** position

E8 ENGINE COOLANT TEMP. SENSOR

1-2 : Approx. **15.0** k Ω (**-20**°C, **-4**°F)
Approx. **2.45** k Ω (**20**°C, **68**°F)
Approx. **0.32** k Ω (**80**°C, **176**°F)
Approx. **0.14** k Ω (**110**°C, **230**°F)

E2 (A), E3 (B), E5 (D), E6 (E) ENGINE CONTROL MODULE

BATT-GROUND : Always approx. **12** volts

+BM-GROUND : Always approx. **12** volts

IGSW-GROUND : Approx. **12** volts with ignition SW at **ON** or **ST** position

+B, +B1-GROUND : Approx. **12** volts with ignition SW at **ON** or **ST** position

VC-GROUND : **4.5-5.5** volts with ignition SW on

VTA2-GROUND : **2.0-2.9** volts with ignition SW on and throttle valve fully closed

4.6-5.0 volts with ignition SW on and throttle valve fully opened

VTA-GROUND : **0.4-1.0** volts with ignition SW on and throttle valve fully closed

3.2-4.8 volts with ignition SW on and throttle valve fully opened

VPA-GROUND : **0.25-0.9** volts with ignition SW at on and accelerator fully closed

3.2-4.8 volts with ignition SW at on and accelerator fully opened

VPA2-GROUND : **1.8-2.7** volts with ignition SW at on and accelerator fully closed

4.7-5.0 volts with ignition SW at on and accelerator fully opened

THA-GROUND : **0.5-3.4** volts with idling, intake air temp. **20**°C (**68**°F)

THW-GROUND : **0.2-1.0** volts with idling, coolant temp. **80**°C (**176**°F)

STA-GROUND : **6.0** volts or more with cranking

TC-GROUND : **9.0-14.0** volts with ignition SW on

W-GROUND : **9.0-14.0** volts with idling

0-3.0 volts with ignition SW on

ACMG-GROUND : **0-1.5** volts with A/C SW on (at idling)

7.5-14.0 volts with A/C SW off and throttle valve fully open

#10, #20, #30, #40, #50, #60, #70, #80-GROUND : **9.0-14.0** volts with ignition SW on pulse generation with idling

I13, I14, I15, I16, I17, I18, I19, I20 INJECTOR NO.1, NO.2, NO.3, NO.4, NO.5, NO.6, NO.7, NO.8

1-2 : **13.4-14.2** Ω

○ : PARTS LOCATION

Code	See Page	Code	See Page	Code	See Page
A10	36 (1UZ-FE)	H21	40	J9	41
A13	40	I2	37 (1UZ-FE)	J10	41
A20	40	I3	37 (1UZ-FE)	J11	41
B5	40	I4	37 (1UZ-FE)	J14	41
C1	36 (1UZ-FE)	I5	37 (1UZ-FE)	J15	41
C3	36 (1UZ-FE)	I6	37 (1UZ-FE)	J17	41
C4	36 (1UZ-FE)	I7	37 (1UZ-FE)	J20	42
C5	36 (1UZ-FE)	I8	37 (1UZ-FE)	K1	37 (1UZ-FE)
C12	A 40	I9	37 (1UZ-FE)	K2	37 (1UZ-FE)
C13	B 40	I13	37 (1UZ-FE)	M1	37 (1UZ-FE)
D1	36 (1UZ-FE)	I14	37 (1UZ-FE)	M3	41
D4	40	I15	37 (1UZ-FE)	P1	37 (1UZ-FE)
E2	A 36 (1UZ-FE)	I16	37 (1UZ-FE)	S11	41
E3	B 36 (1UZ-FE)	I17	37 (1UZ-FE)	T2	37 (1UZ-FE)
E4	C 36 (1UZ-FE)	I18	37 (1UZ-FE)	T3	37 (1UZ-FE)
E5	D 36 (1UZ-FE)	I19	37 (1UZ-FE)	T5	41
E6	E 36 (1UZ-FE)	I20	37 (1UZ-FE)	T6	41
E7	F 36 (1UZ-FE)	I22	41	V2	37 (1UZ-FE)
E8	36 (1UZ-FE)	J2	37 (1UZ-FE)	V3	37 (1UZ-FE)
F15	42	J3	A 37 (1UZ-FE)	V4	37 (1UZ-FE)
F16	42	J4	B 37 (1UZ-FE)	V5	37 (1UZ-FE)
H12	36 (1UZ-FE)	J5	37 (1UZ-FE)	V10	43
H14	36 (1UZ-FE)	J6	41	V11	43
H20	40	J7	41		

○ : RELAY BLOCKS

Code	See Page	Relay Blocks (Relay Block Location)
1	22	Engine Room No.1 R/B (Engine Compartment Right)

○ : JUNCTION BLOCK AND WIRE HARNESS CONNECTOR

Code	See Page	Junction Block and Wire Harness (Connector Location)
1D	26	Instrument Panel Wire and Driver Side J/B (Left Kick Panel)
1F	26	Cowl Wire and Driver Side J/B (Left Kick Panel)
1G	27	
1H		
1J		
1K	26	Engine Room Main Wire and Driver Side J/B (Left Kick Panel)
2F	28	Cowl Wire and Passenger Side J/B (Right Kick Panel)
2G	29	

ENGINE CONTROL (1UZ-FE)

□ : CONNECTOR JOINING WIRE HARNESS AND WIRE HARNESS

Code	See Page	Joining Wire Harness and Wire Harness (Connector Location)
EA1	46 (1UZ-FE)	Engine Wire and Cowl Wire (Inside of the ECU Box)
EA2		
EA3		
EA4		
EB1	46 (1UZ-FE)	Cowl Wire and Relay Block Wire (Inside of the Engine Room No.3 R/B)
EC1	46 (1UZ-FE)	Engine No.2 Wire and Engine Wire (Near the Starter)
IA1	50	Engine Room Main Wire and Cowl Wire (Near the Driver Side J/B)
IA2		
IC2	50	Floor No.2 Wire and Cowl Wire (Left Kick Panel)
IC3		
IE1	50	Instrument Panel Wire and Cowl Wire (Left Side of the Steering Column)
IE2		
II1	52	Engine Room Main Wire and Cowl Wire (Near the Passenger Side R/B)
II4		
IJ1	52	Instrument Panel Wire and Cowl Wire (Left Side of the Blower Unit)

▽ : GROUND POINTS

Code	See Page	Ground Points Location
EB	46 (1UZ-FE)	Left Fender
EC	46 (1UZ-FE)	RH Bank of the Cylinder Head
ED	46 (1UZ-FE)	LH Bank of the Cylinder Head
EE	46 (1UZ-FE)	Under the ABS & TRAC & VSC Actuator
IF	50	Left Kick Panel
II	50	Right Side of the Cowl Panel
BJ	54	Rear Floor Partition Panel LH
BK	54	Quarter Panel LH

○ : SPLICE POINTS

Code	See Page	Wire Harness with Splice Points	Code	See Page	Wire Harness with Splice Points
E1	46 (1UZ-FE)	Engine Wire	E4	46 (1UZ-FE)	Cowl Wire
E2			B3	54	Floor No.2 Wire
E3					

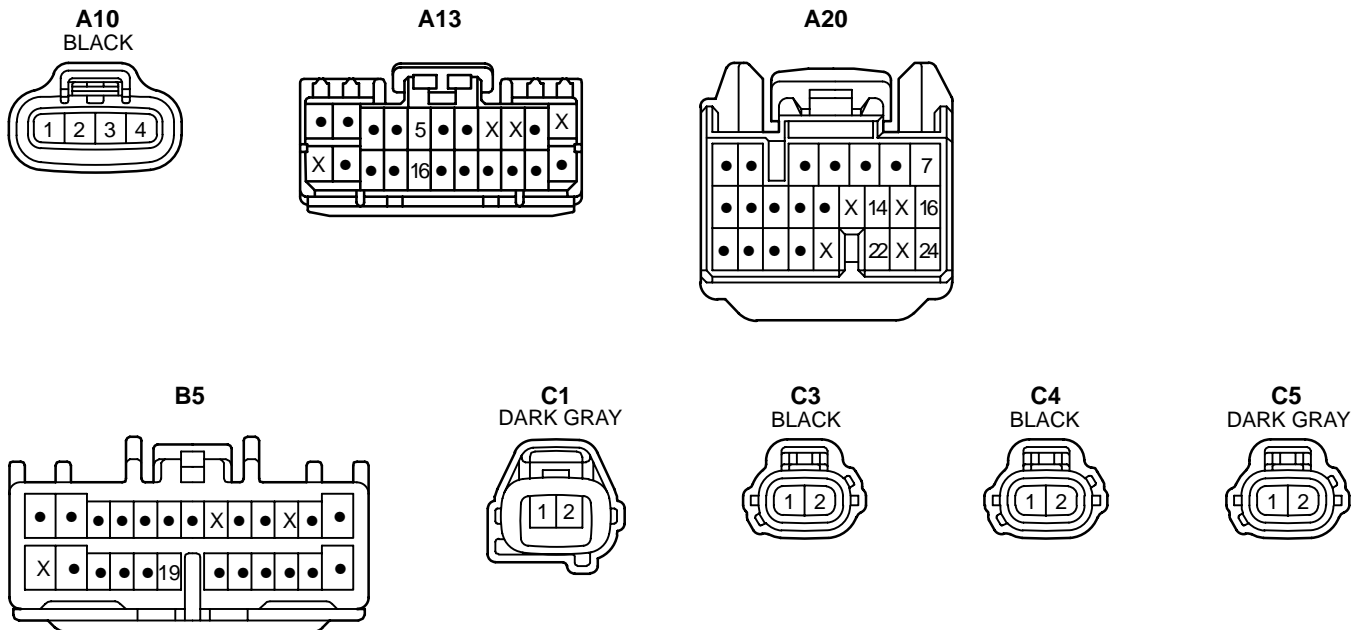

C12 (A)

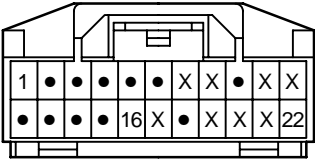

C13 (B)

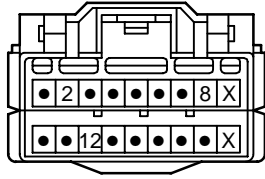

D1
BLACK

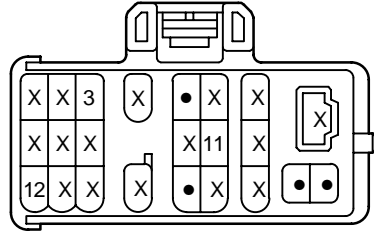

D4

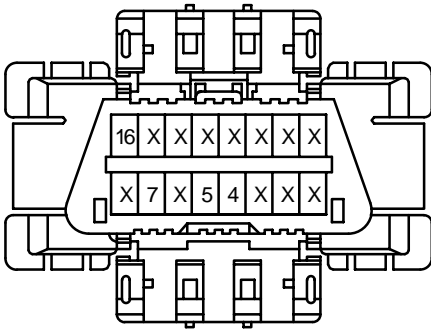

E2 (A)

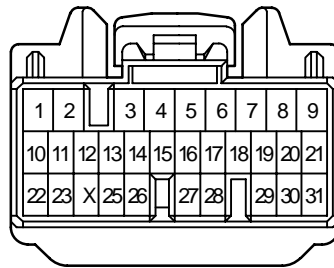

E3 (B)

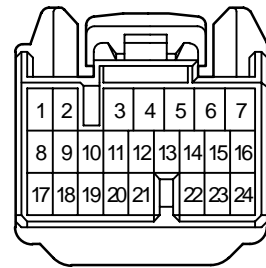

E4 (C)

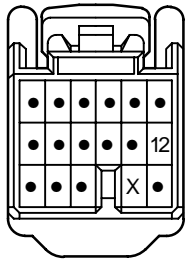

E5 (D)

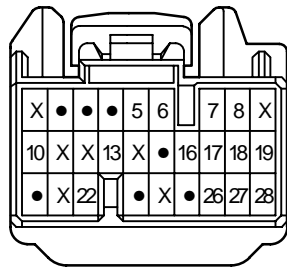

E6 (E)

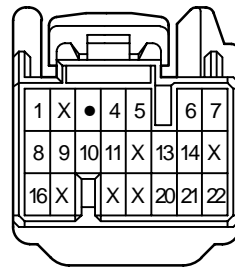

E7 (F)

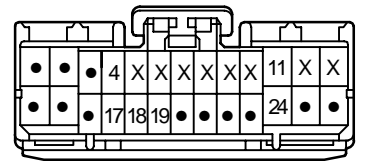

E8
BLACK



F15



F16
BLACK

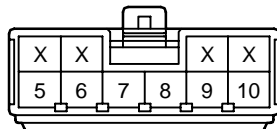

H12
DARK GRAY



H14
DARK GRAY



H20
DARK GRAY

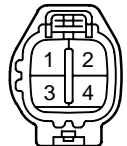

H21
DARK GRAY



I2
BLACK

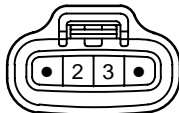

I3
BLACK

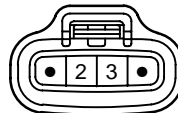

I4
BLACK

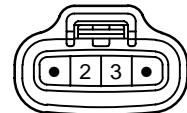

ENGINE CONTROL (1UZ-FE)

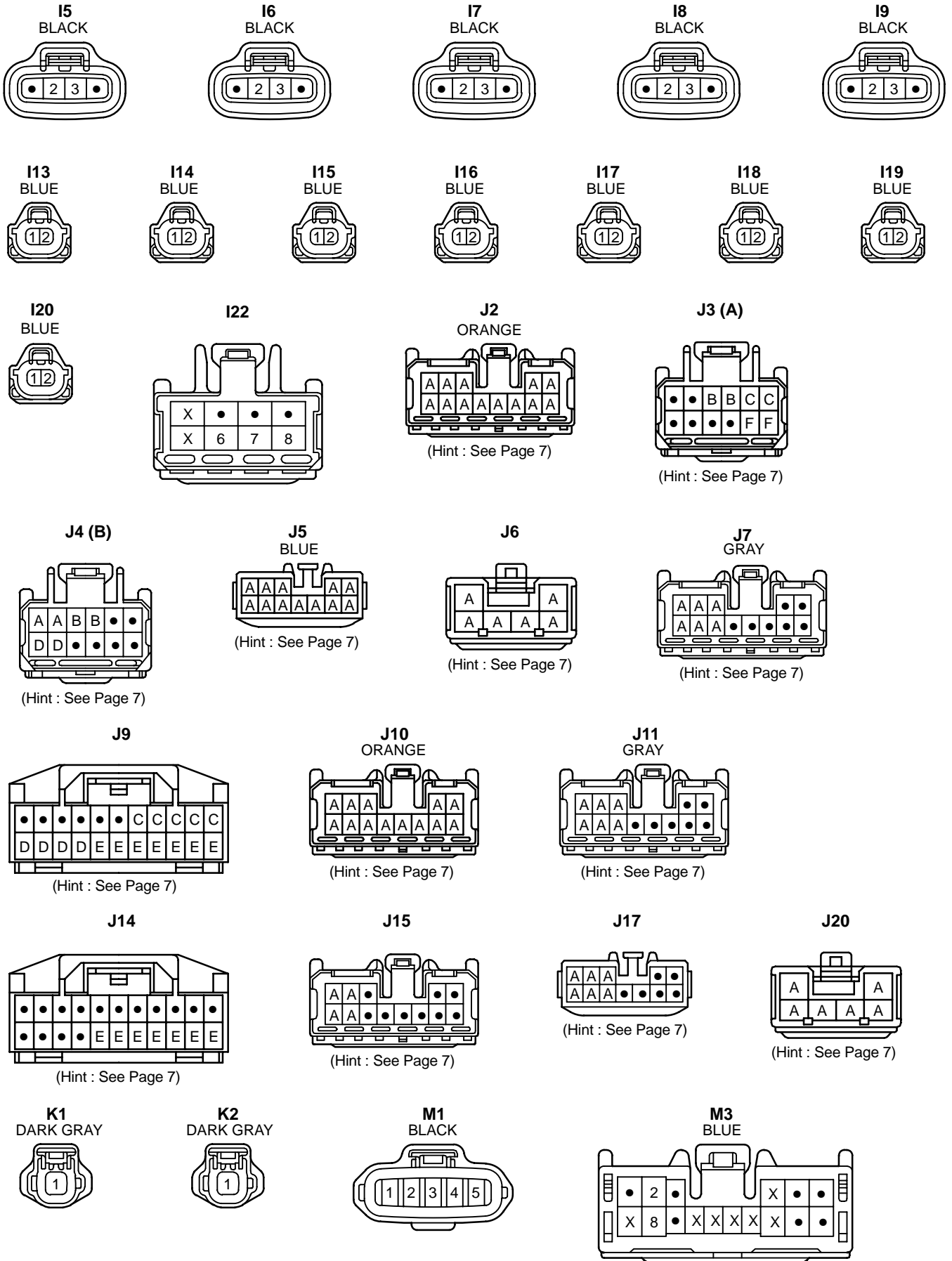

P1
GRAY

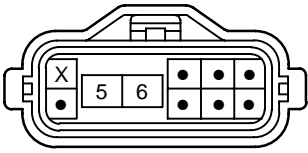

S11
BLUE

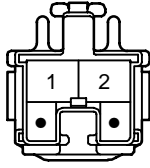

T2
GRAY



T3
GRAY

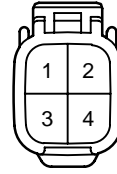

T5
GRAY

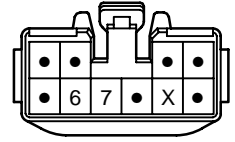

T6
BLACK

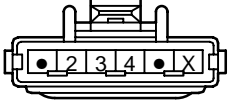

V2
BLACK

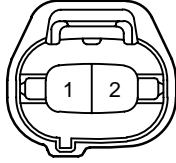

V3
BLACK

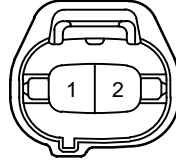

V4
DARK GRAY



V5
DARK GRAY



V10
BLACK

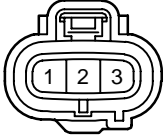

V11
BLUE



ENGINE CONTROL (2JZ-GE)

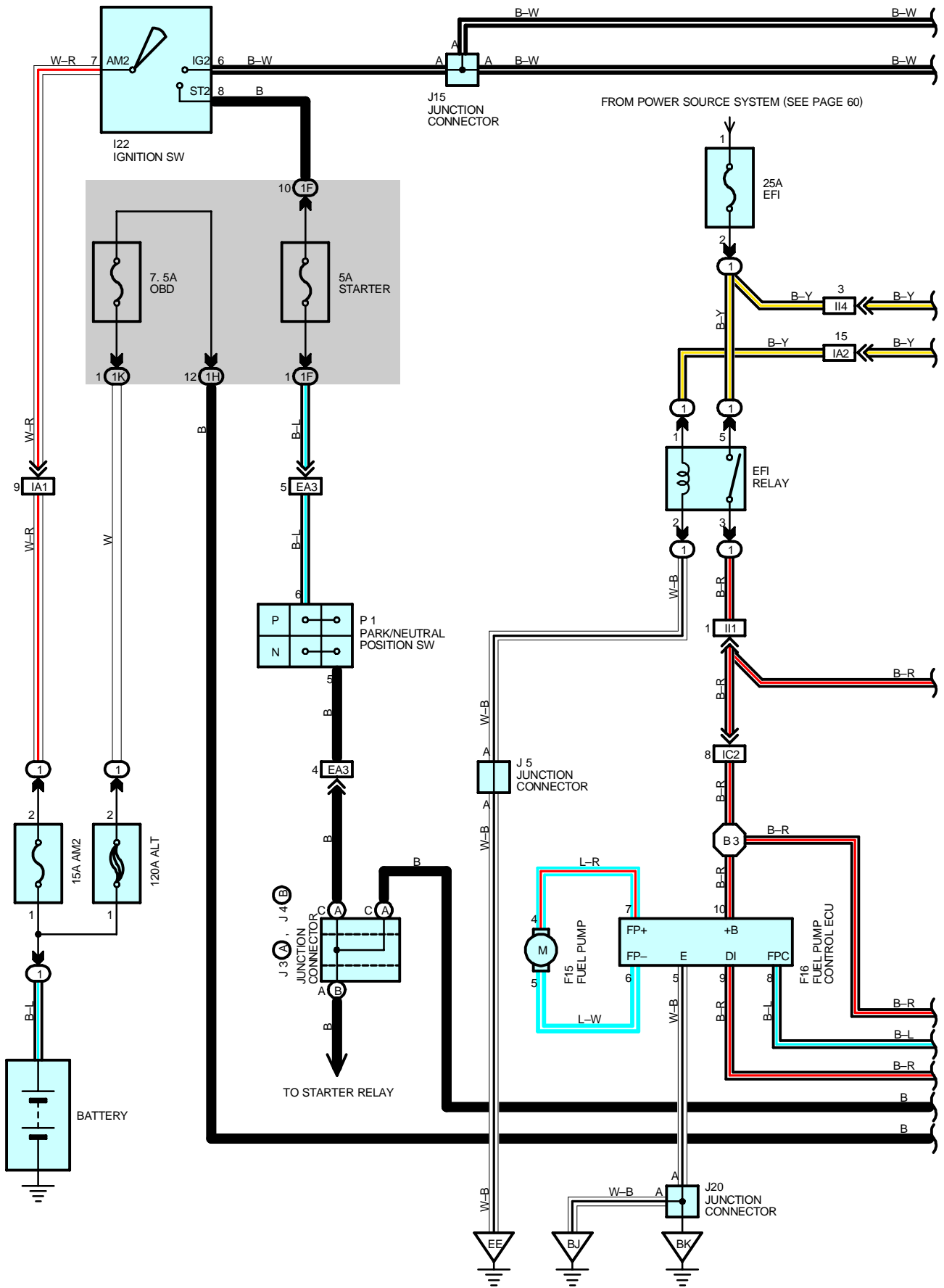

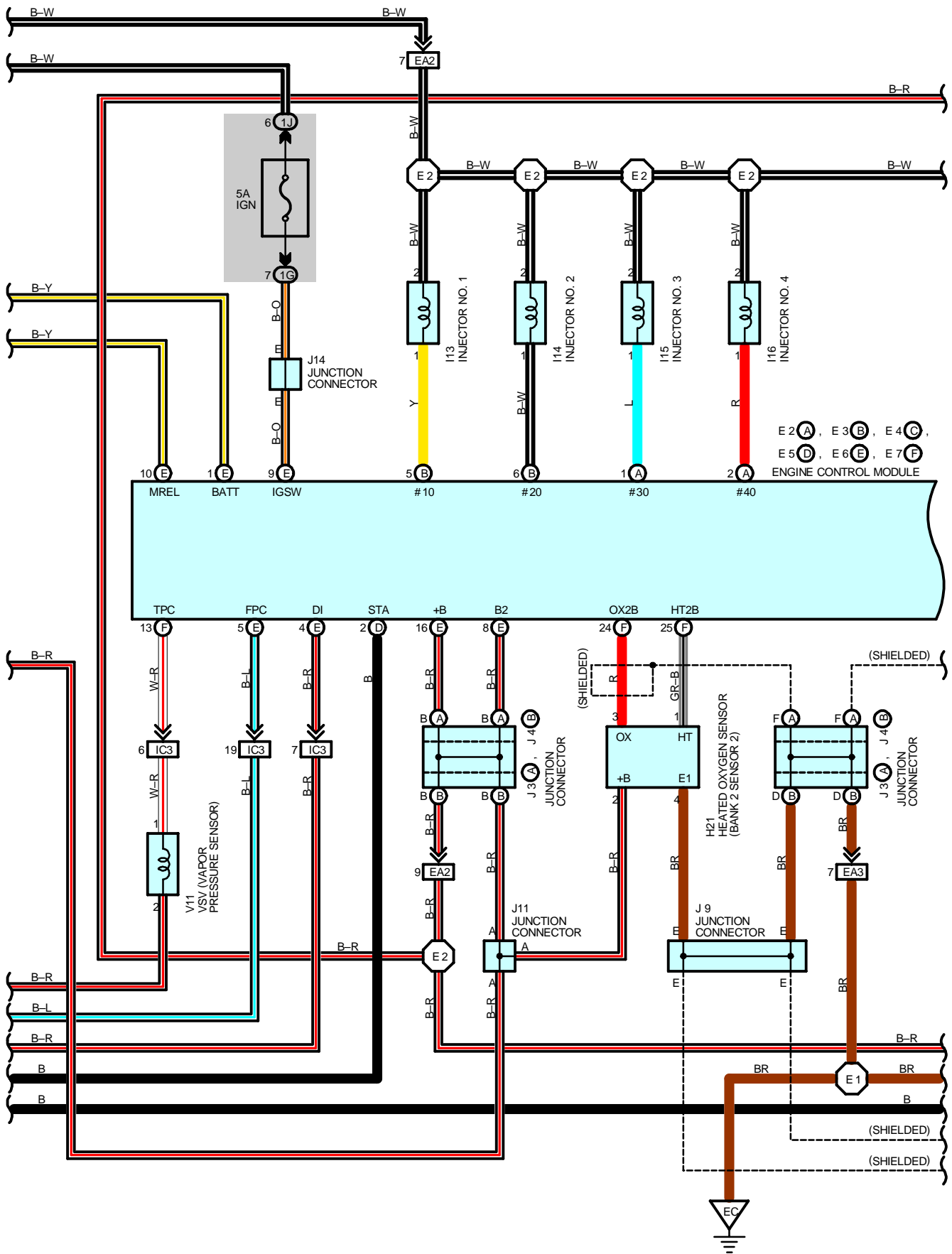

ENGINE CONTROL (2JZ-GE)

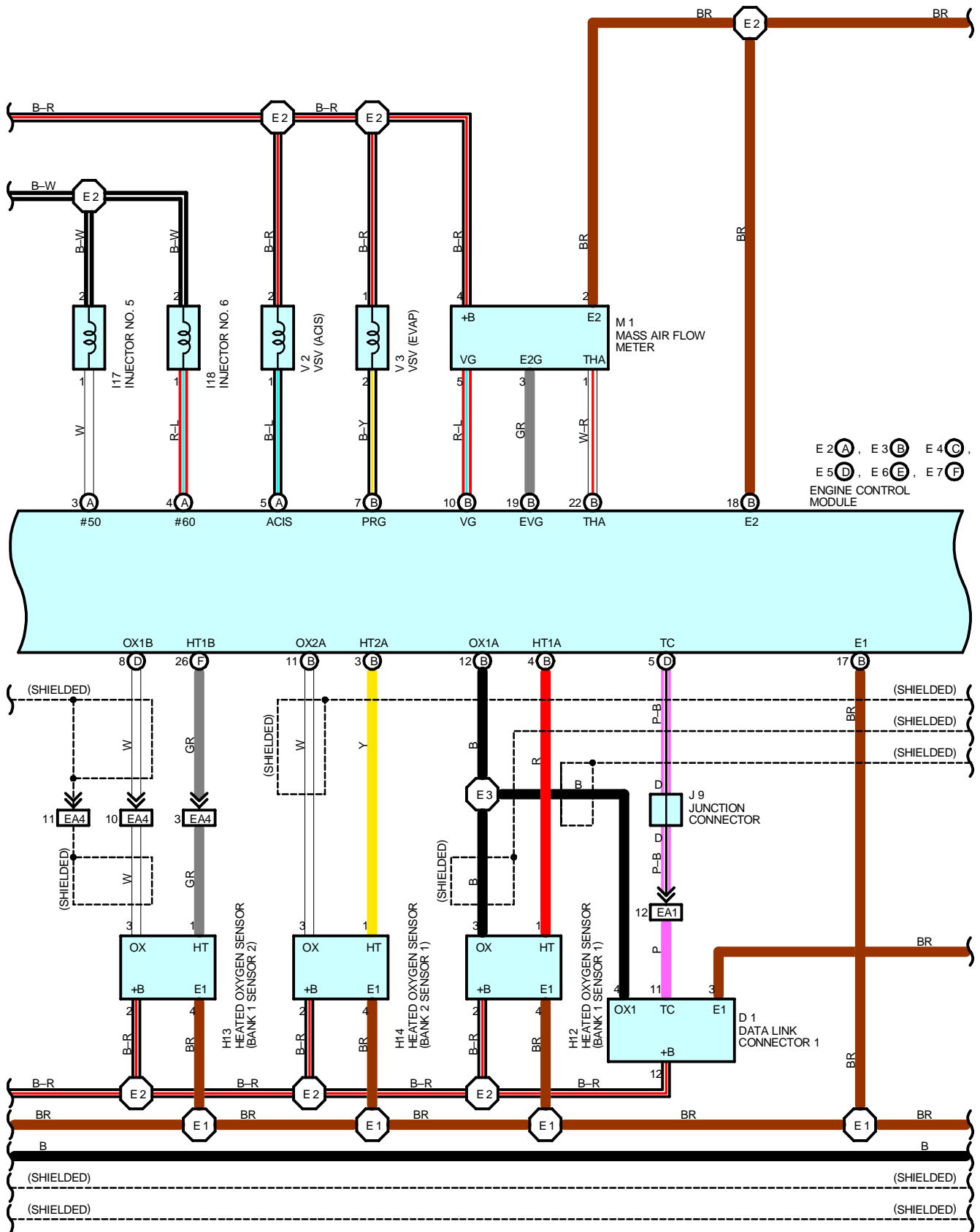

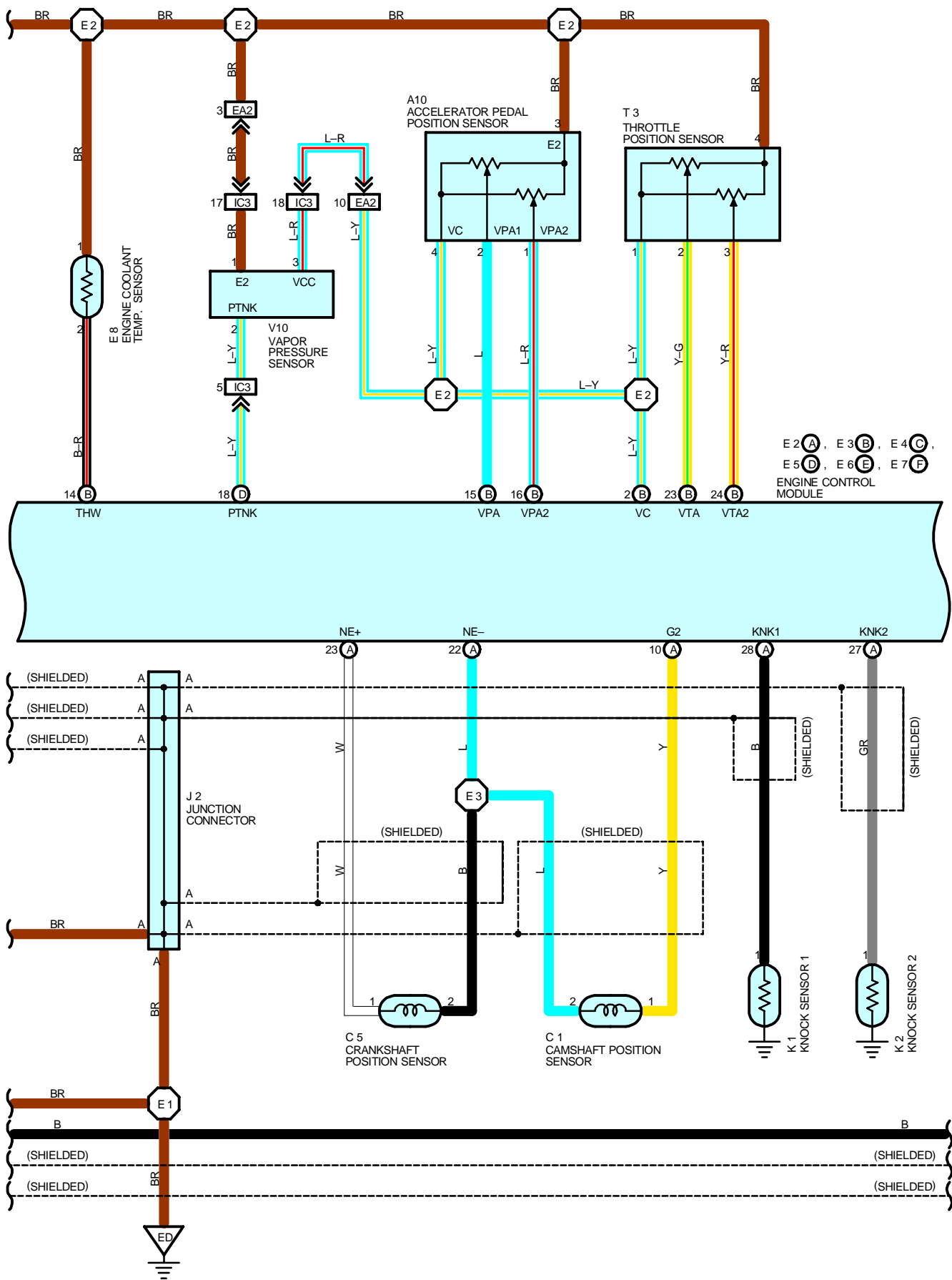

ENGINE CONTROL (2JZ-GE)

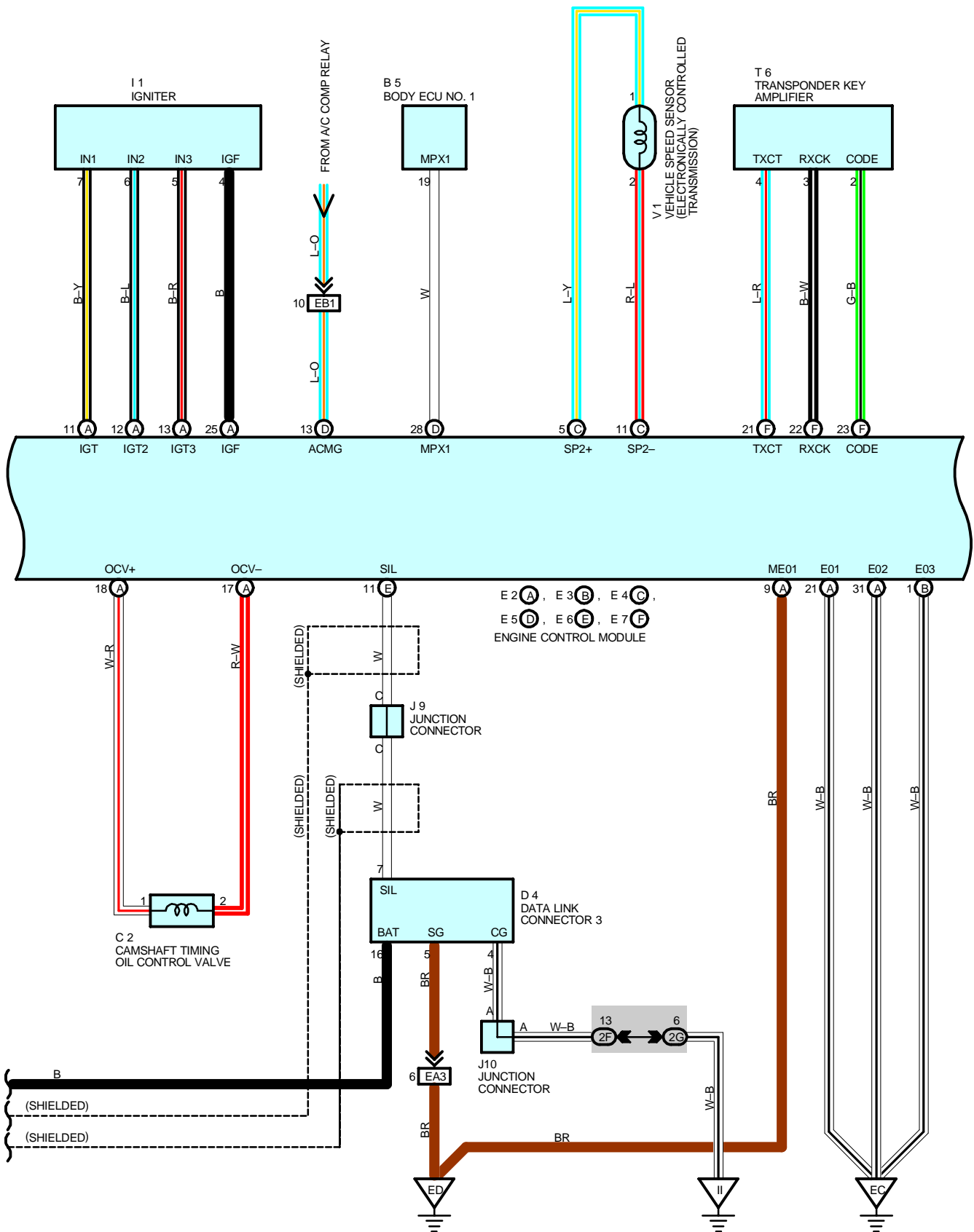

FROM POWER SOURCE SYSTEM (SEE PAGE 60)

* 1 : W/ DAYTIME RUNNING LIGHT
 * 2 : W/O DAYTIME RUNNING LIGHT

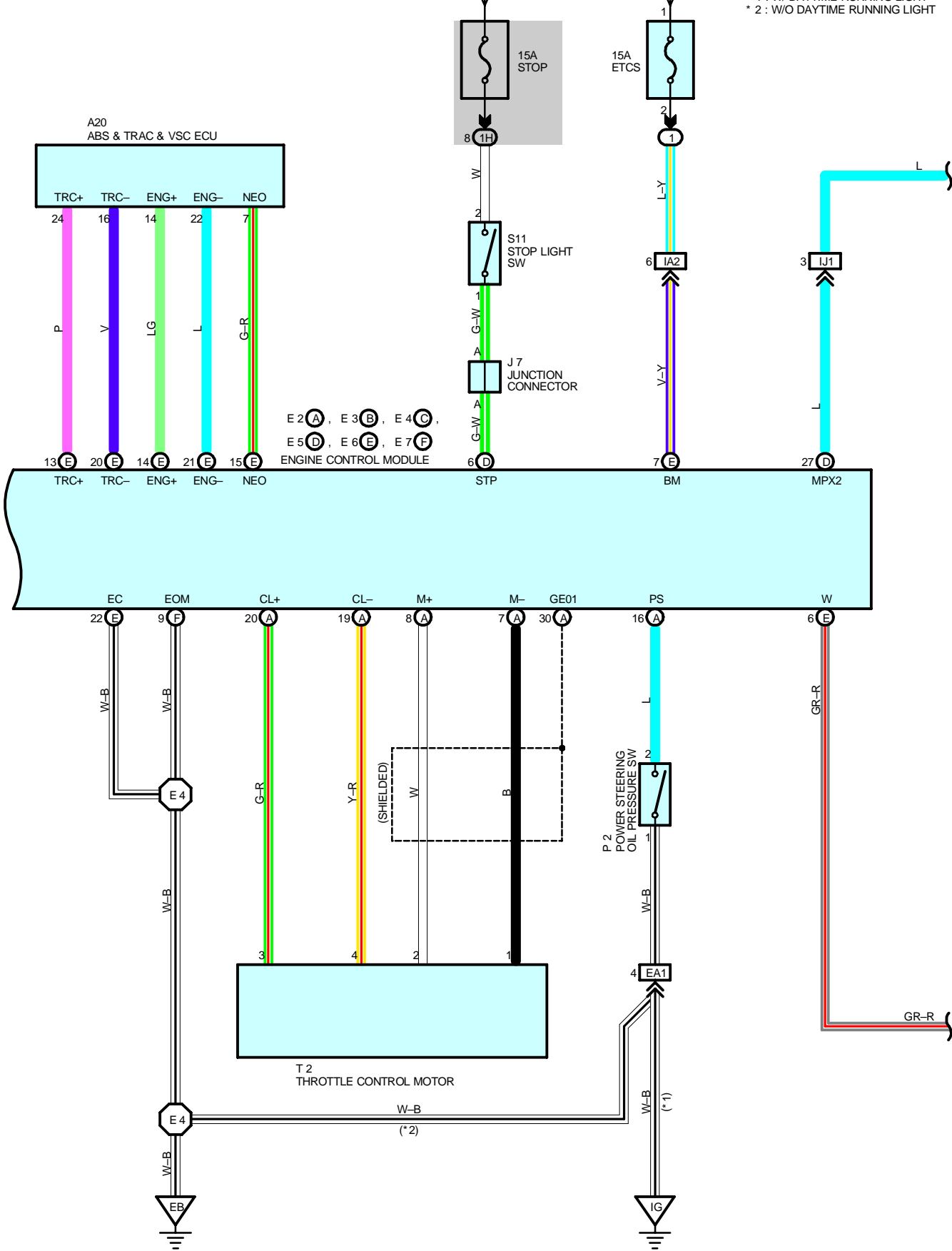

ENGINE CONTROL (2JZ-GE)

FROM POWER SOURCE SYSTEM (SEE PAGE 60)

- * 3 : W/ LEXUS NAVIGATION SYSTEM
- * 4 : W/O LEXUS NAVIGATION SYSTEM

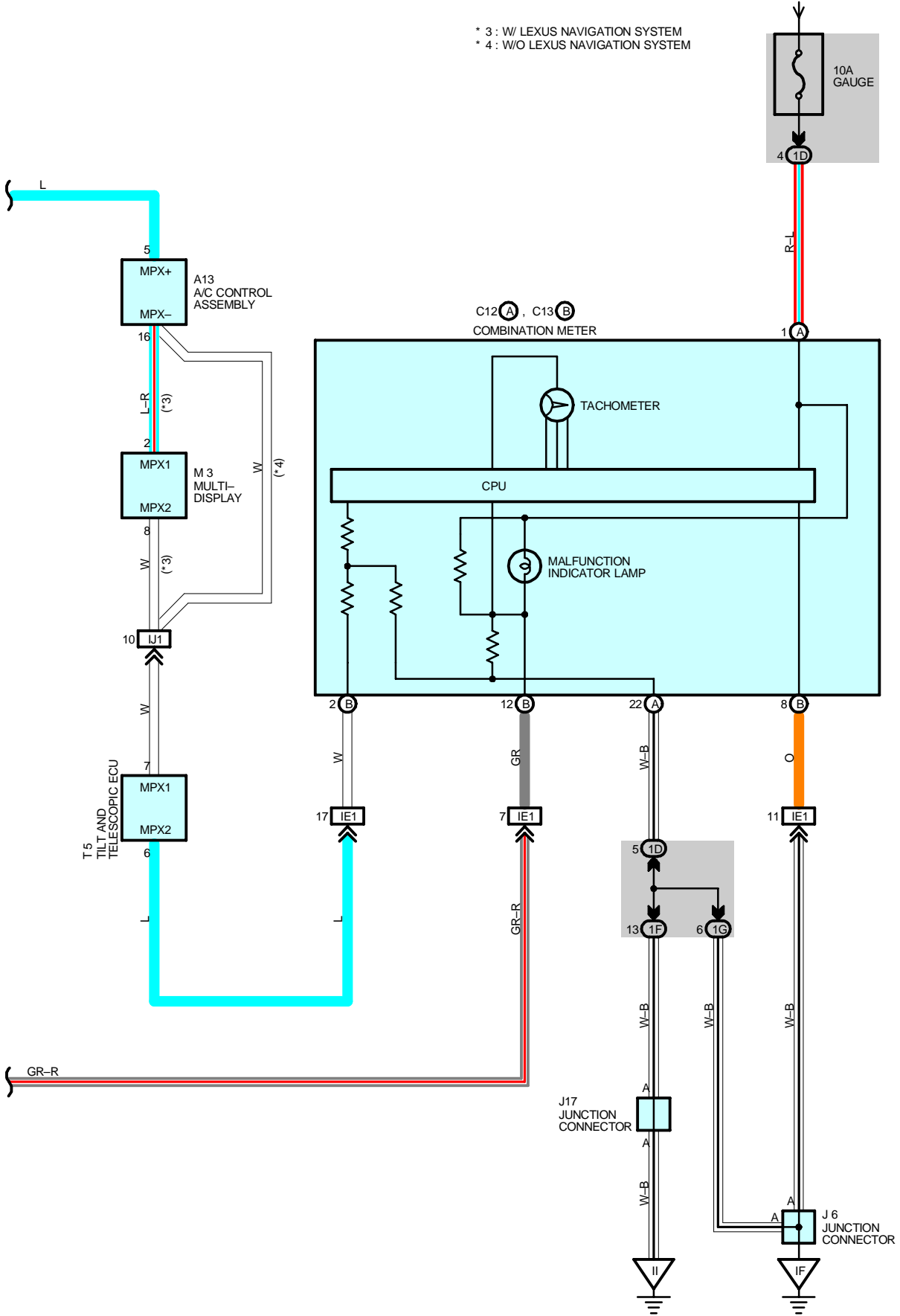

SYSTEM OUTLINE

The engine control system utilizes a microcomputer and maintains overall control of the engine, transmission etc. An outline of the engine control is given here.

1. INPUT SIGNALS

- (1) Engine coolant temp. signal circuit
The engine coolant temp. sensor detects the engine coolant temp. and has a built-in thermister with a resistance, which varies according to the engine coolant temp. The engine coolant temp. is input into TERMINAL THW of the engine control module as a control signal.
- (2) Intake air temp. signal circuit
The intake air temp. sensor is installed in the mass air flow meter and detects the intake air temp. which is input as a control signal to TERMINAL THA of the engine control module.
- (3) Oxygen density signal circuit
The oxygen density in the exhaust emission is detected by the heated oxygen sensors and input as a control signal to TERMINALS OX1A, OX2A, OX1B and OX2B of the engine control module.
- (4) RPM signal circuit
Camshaft position is detected by the camshaft position sensor and its signal is input to TERMINAL G2 of the engine control module as a control signal.
Also, engine RPM is detected by the crankshaft position sensor and is input as a control signal to TERMINAL NE+.
- (5) Throttle position signal circuit
The throttle position sensor detects the throttle valve opening angle as a control signal, which is input into TERMINAL VTA of the engine control module.
- (6) Vehicle speed circuit
The vehicle speed sensor (Electronically controlled transmission) detects the vehicle speed and inputs a control signal to TERMINAL SP2+ of the engine control module.
- (7) Battery signal circuit
Voltage is constantly applied to TERMINAL BATT of the engine control module. With the ignition SW turned on, the voltage for engine control module start-up power supply is applied to TERMINALS +B, B2 of the engine control module via the EFI relay.
The current flowing through the IGN fuse flows to TERMINAL IGSW of the engine control module.
Voltage is constantly applied to TERMINAL BM of the engine control module.
- (8) Intake air volume signal circuit
Intake air volume is detected by the mass air flow meter and the signal is input to TERMINAL VG of the engine control module as a control signal.
- (9) Stop light SW signal circuit
The stop light SW is used to detect whether the vehicle is braking or not and the signal is input into TERMINAL STP of the engine control module as a control signal.
- (10) Starter signal circuit
To confirm whether the engine is cranking, the voltage is applied to the starter motor during cranking is detected and the signal is input into TERMINAL STA of the engine control module as a control signal.
- (11) Engine knock signal circuit
Engine knocking is detected by knock sensors and the signal is input into TERMINALS KNK1 and KNK2 as a control signal.

ENGINE CONTROL (2JZ-GE)

2. CONTROL SYSTEM

* SFI system

The SFI system monitors the engine condition through the signals input from each sensor (Input signals from (1) to (11) etc.) to the engine control module. And the control signal is output to TERMINALS #10, #20, #30, #40, #50 and #60 of the engine control module to operate the injector (Inject the fuel). The SFI system controls the fuel injection operation by the engine control module in response to the driving conditions.

* ESA system

The ESA system monitors the engine condition through the signals input to the engine control module from each sensor (Input signals from (1), (2), (4), to (11) etc.). The best ignition timing is decided according to this data and the memorized data in the engine control module and the control signal is output to TERMINALS IGT, IGT2, IGT3. This signal controls the igniter to provide the best ignition timing for the driving conditions.

* Heated oxygen sensor heater control system

The heated oxygen sensor heater control system turns the heater on when the intake air volume is low (Temp. of exhaust emissions is low), and warms up the oxygen sensors to improve detection performance of the sensors. The engine control module evaluates the signals from each sensor (Input signals from (1), (2), (4), (7), to (9) etc.), and outputs current to TERMINALS HT1A, HT2A, HT1B and HT2B to control the heater.

* Fuel pump control system

The engine control module outputs current to TERMINAL FPC and controls the fuel pump control ECU and fuel pump drive speed in response to the driving conditions.

* ACIS

ACIS includes a valve in the bulkhead separating the surge tank into two parts. This valve is opened and closed in accordance with the driving conditions to control the intake manifold length in two stages for increased engine output in all ranges from low to high speeds.

* ETCS-i

The ETCS-i controls the engine output at its optimal level corresponding to the opening of the accel. pedal under all driving conditions.

* MPX

The MPX communicates with the combination meter, A/C control assembly, as well as body ECU of the multiplex communication system

3. DIAGNOSIS SYSTEM

With the diagnosis system, when there is a malfunction in the engine control module signal system, the malfunctioning system is recorded in the memory. The malfunctioning system can be found by reading the code displayed by the malfunction indicator lamp.

4. FAIL-SAFE SYSTEM

When a malfunction has occurred in any system, if there is a possibility of engine trouble being caused by continued control based on the signals from that system, the fail-safe system either controls the system by using data (Standard values) recorded in the engine control module memory or else stops the engine.

SERVICE HINTS

EFI RELAY

5-3 : Closed with ignition SW at **ON** or **ST** position

E8 ENGINE COOLANT TEMP. SENSOR

1-2 : Approx. **15.0** k Ω (**-20**°C, **-4**°F)
Approx. **2.45** k Ω (**20**°C, **68**°F)
Approx. **0.32** k Ω (**80**°C, **176**°F)
Approx. **0.14** k Ω (**110**°C, **230**°F)

E2 (A), E3 (B), E5 (D), E6 (E) ENGINE CONTROL MODULE

BATT-GROUND : Always approx. **12** volts

BM-GROUND : Always approx. **12** volts

IGSW-GROUND : Approx. **12** volts with ignition SW at **ON** or **ST** position

+B, B2-GROUND : Approx. **12** volts with ignition SW at **ON** or **ST** position

VC-GROUND : **4.5-5.5** volts with ignition SW on

VTA2-GROUND : **2.0-2.9** volts with ignition SW on and throttle valve fully closed

4.6-5.0 volts with ignition SW on and throttle valve fully opened

VTA-GROUND : **0.4-1.0** volts with ignition SW on and throttle valve fully closed

3.2-4.8 volts with ignition SW on and throttle valve fully opened

VPA-GROUND : **0.25-0.9** volts with ignition SW at on and accelerator fully closed

3.2-4.8 volts with ignition SW at on and accelerator fully opened

VPA2-GROUND : **1.8-2.7** volts with ignition SW at on and accelerator fully closed

4.7-5.0 volts with ignition SW at on and accelerator fully opened

THA-GROUND : **0.5-3.4** volts with idling, intake air temp. **20**°C (**68**°F)

THW-GROUND : **0.2-1.0** volts with idling, coolant temp. **80**°C (**176**°F)

STA-GROUND : **6.0** volts or more with cranking

TC-GROUND : **9.0-14.0** volts with ignition SW on

W-GROUND : **9.0-14.0** volts with idling

0-3.0 volts with ignition SW on

ACMG-GROUND : **0-1.5** volts with A/C SW on (at idling)

7.5-14.0 volts with A/C SW off and throttle valve fully open

#10, #20, #30, #40, #50, #60-GROUND : **9.0-14.0** volts with ignition SW on pulse generation with idling

I13, I14, I15, I16, I17, I18 INJECTOR NO.1, NO.2, NO.3, NO.4, NO.5, NO.6

1-2 : **13.4-14.2** Ω

ENGINE CONTROL (2JZ-GE)

○ : PARTS LOCATION

Code	See Page	Code	See Page	Code	See Page
A10	38 (2JZ-GE)	H13	38 (2JZ-GE)	J15	41
A13	40	H14	38 (2JZ-GE)	J17	41
A20	40	H21	40	J20	42
B5	40	I1	39 (2JZ-GE)	K1	39 (2JZ-GE)
C1	38 (2JZ-GE)	I13	39 (2JZ-GE)	K2	39 (2JZ-GE)
C2	38 (2JZ-GE)	I14	39 (2JZ-GE)	M1	39 (2JZ-GE)
C5	38 (2JZ-GE)	I15	39 (2JZ-GE)	M3	41
C12	A 40	I16	39 (2JZ-GE)	P1	39 (2JZ-GE)
C13	B 40	I17	39 (2JZ-GE)	P2	39 (2JZ-GE)
D1	38 (2JZ-GE)	I18	39 (2JZ-GE)	S11	41
D4	40	I22	41	T2	39 (2JZ-GE)
E2	A 38 (2JZ-GE)	J2	39 (2JZ-GE)	T3	39 (2JZ-GE)
E3	B 38 (2JZ-GE)	J3	A 39 (2JZ-GE)	T5	41
E4	C 38 (2JZ-GE)	J4	B 39 (2JZ-GE)	T6	41
E5	D 38 (2JZ-GE)	J5	39 (2JZ-GE)	V1	39 (2JZ-GE)
E6	E 38 (2JZ-GE)	J6	41	V2	39 (2JZ-GE)
E7	F 38 (2JZ-GE)	J7	41	V3	39 (2JZ-GE)
E8	38 (2JZ-GE)	J9	41	V10	43
F15	42	J10	41	V11	43
F16	42	J11	41		
H12	38 (2JZ-GE)	J14	41		

○ : RELAY BLOCKS

Code	See Page	Relay Blocks (Relay Block Location)
1	22	Engine Room No.1 R/B (Engine Compartment Right)

○ : JUNCTION BLOCK AND WIRE HARNESS CONNECTOR

Code	See Page	Junction Block and Wire Harness (Connector Location)
1D	26	Instrument Panel Wire and Driver Side J/B (Left Kick Panel)
1F	26	Cowl Wire and Driver Side J/B (Left Kick Panel)
1G	27	Cowl Wire and Driver Side J/B (Left Kick Panel)
1H		
1J		
1K	26	Engine Room Main Wire and Driver Side J/B (Left Kick Panel)
2F	28	Cowl Wire and Passenger Side J/B (Right Kick Panel)
2G	29	

□ : CONNECTOR JOINING WIRE HARNESS AND WIRE HARNESS

Code	See Page	Joining Wire Harness and Wire Harness (Connector Location)
EA1	48 (2JZ-GE)	Engine Wire and Cowl Wire (Inside of the ECU Box)
EA2		
EA3		
EA4		
EB1	48 (2JZ-GE)	Cowl Wire and Relay Block Wire (Inside of the Engine Room No.3 R/B)
IA1	50	Engine Room Main Wire and Cowl Wire (Near the Driver Side J/B)
IA2		
IC2	50	Floor No.2 Wire and Cowl Wire (Left Kick Panel)
IC3		
IE1	50	Instrument Panel Wire and Cowl Wire (Left Side of the Steering Column)
II1	52	Engine Room Main Wire and Cowl Wire (Near the Passenger Side R/B)
II4		
IJ1	52	Instrument Panel Wire and Cowl Wire (Left Side of the Blower Unit)

▽ : GROUND POINTS

Code	See Page	Ground Points Location
EB	48 (2JZ-GE)	Left Fender
EC	48 (2JZ-GE)	Front Side of the Intake Manifold
ED	48 (2JZ-GE)	Rear Side of the Intake Manifold
EE	48 (2JZ-GE)	Under the ABS & TRAC & VSC Actuator
IF	50	Left Kick Panel
IG	50	Left Side of the Cowl Panel
II	50	Right Side of the Cowl Panel
BJ	54	Rear Floor Partition Panel LH
BK	54	Quarter Panel LH

○ : SPLICE POINTS

Code	See Page	Wire Harness with Splice Points	Code	See Page	Wire Harness with Splice Points
E1	48 (2JZ-GE)	Engine Wire	E4	48 (2JZ-GE)	Cowl Wire
E2			B3	54	Floor No.2 Wire
E3					

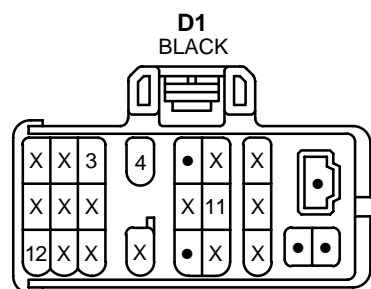
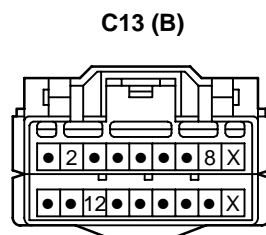
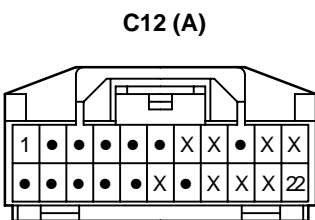
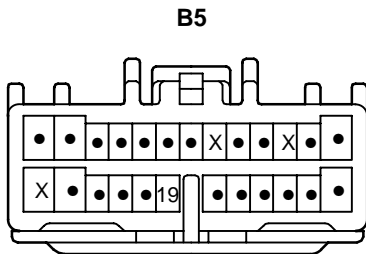
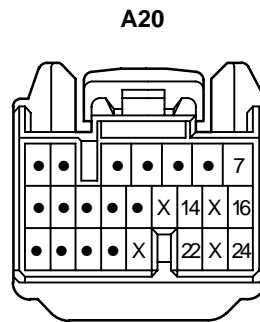
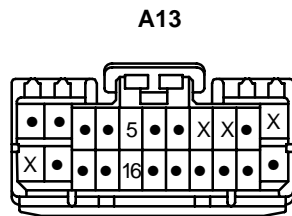

ENGINE CONTROL (2JZ-GE)

D4

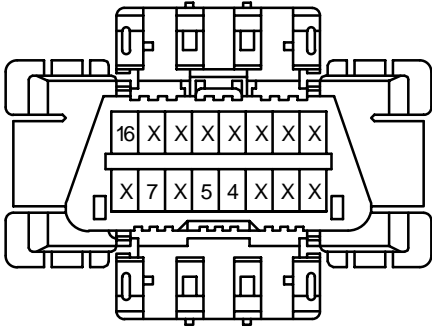

E2 (A)

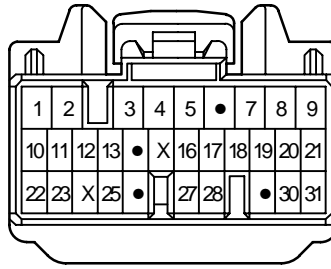

E3 (B)

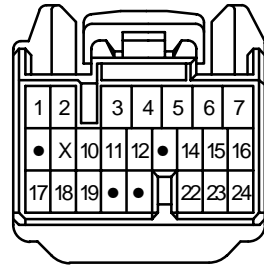

E4 (C)

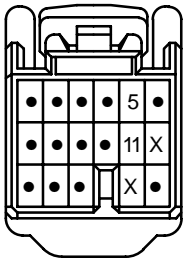

E5 (D)

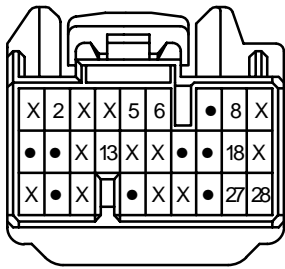

E6 (E)

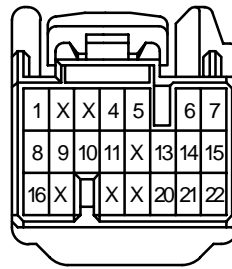

E7 (F)

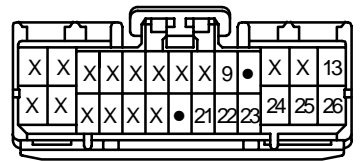

E8
BLACK



F15



F16
BLACK

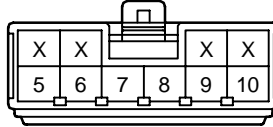

H12
DARK GRAY



H13
DARK GRAY



H14
DARK GRAY



H21
DARK GRAY



I1
BLACK

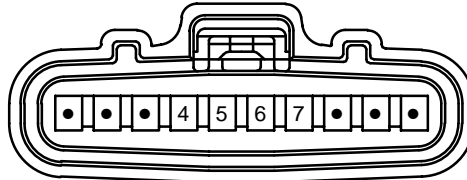

I13
DARK GRAY



I14
BROWN



I15
DARK GRAY



I16
BROWN



I17
DARK GRAY



I18
BROWN



I22

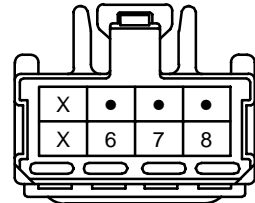

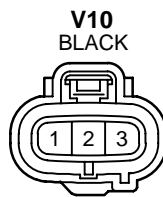
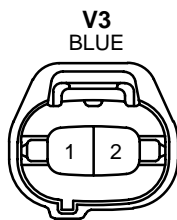
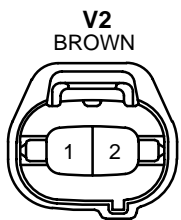
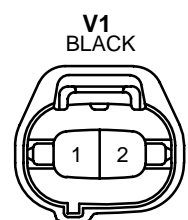
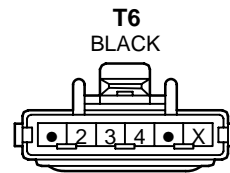
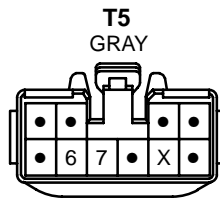
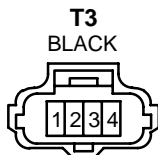
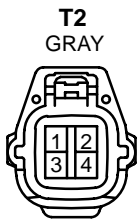
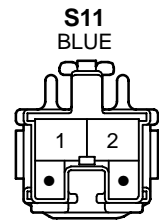
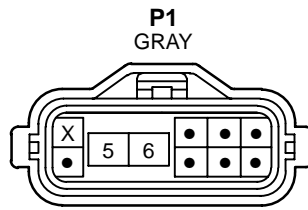
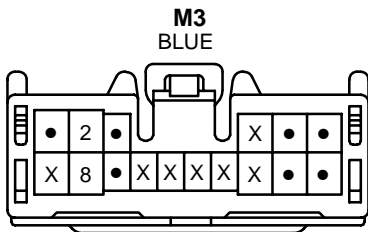
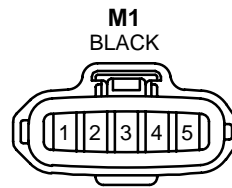
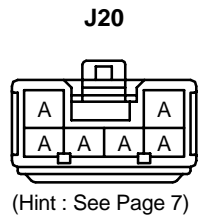
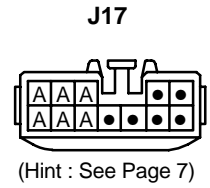
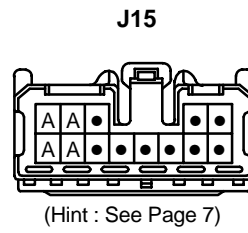
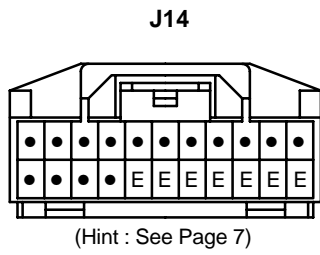
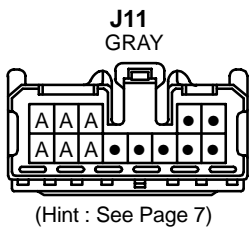
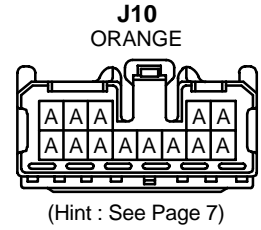
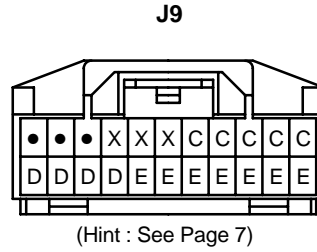
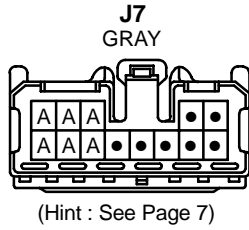
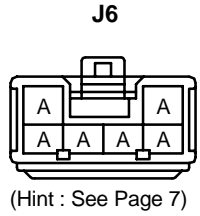
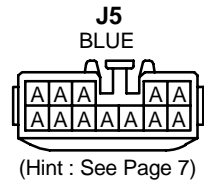
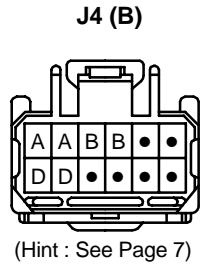
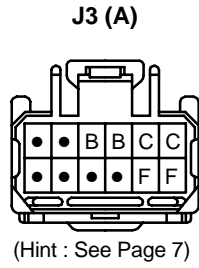
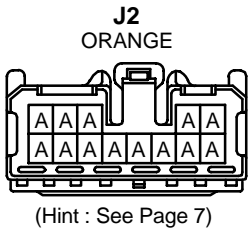

ENGINE IMMOBILISER SYSTEM (1UZ-FE)

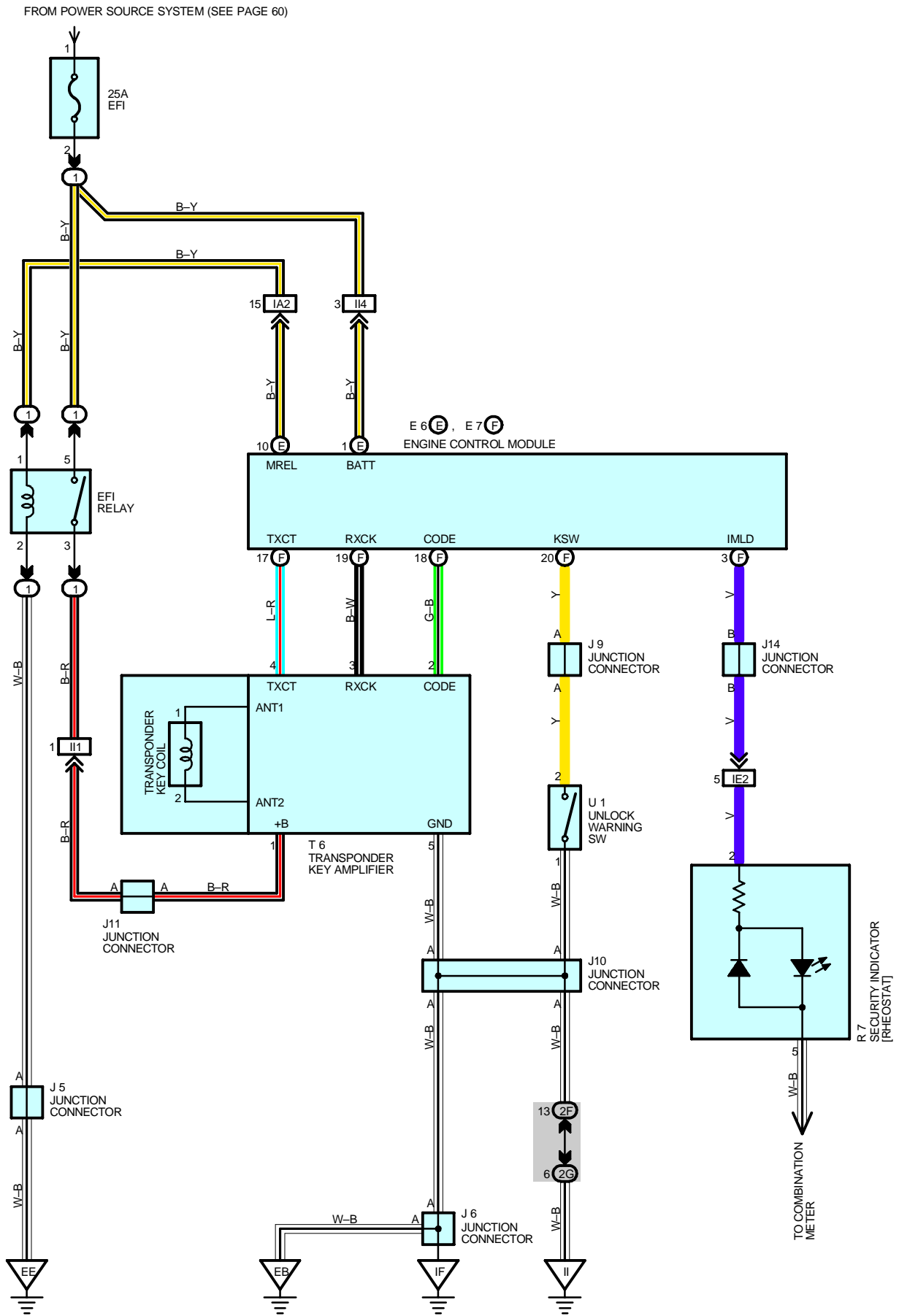

SERVICE HINTS

EFI RELAY

5-3 : Closed with the ignition SW at **ON** position

U1 UNLOCK WARNING SW

1-2 : Closed with the ignition key in cylinder

○ : PARTS LOCATION

Code	See Page	Code	See Page	Code	See Page	
E6	E	36 (1UZ-FE)	J9	41	R7	41
E7	F	36 (1UZ-FE)	J10	41	T6	41
J5		37 (1UZ-FE)	J11	41	U1	41
J6		41	J14	41		

○ : RELAY BLOCKS

Code	See Page	Relay Blocks (Relay Block Location)
1	22	Engine Room No.1 R/B (Engine Compartment Right)

○ : JUNCTION BLOCK AND WIRE HARNESS CONNECTOR

Code	See Page	Junction Block and Wire Harness (Connector Location)
2F	28	Cowl Wire and Passenger Side J/B (Right Kick Panel)
2G	29	

□ : CONNECTOR JOINING WIRE HARNESS AND WIRE HARNESS

Code	See Page	Joining Wire Harness and Wire Harness (Connector Location)
IA2	50	Engine Room Main Wire and Cowl Wire (Near the Driver Side J/B)
IE2	50	Instrument Panel Wire and Cowl Wire (Left Side of the Steering Column)
II1	52	Engine Room Main Wire and Cowl Wire (Near the Passenger Side R/B)
II4		

▽ : GROUND POINTS

Code	See Page	Ground Points Location
EB	46 (1UZ-FE)	Left Fender
EE	46 (1UZ-FE)	Under the ABS & TRAC & VSC Actuator
IF	50	Left Kick Panel
II	50	Right Side of the Cowl Panel

E6 (E)

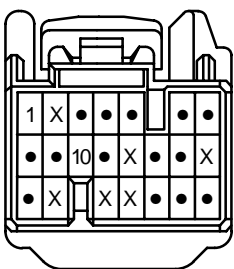

E7 (F)

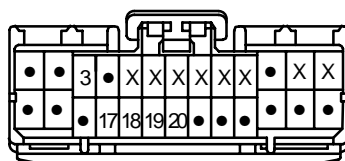

**J5
BLUE**



(Hint : See Page 7)

J6

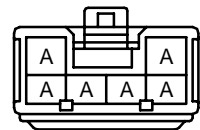

(Hint : See Page 7)

J9

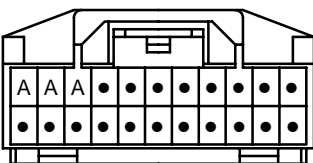

(Hint : See Page 7)

**J10
ORANGE**

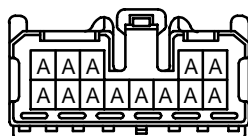

(Hint : See Page 7)

**J11
GRAY**

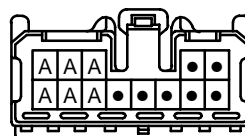

(Hint : See Page 7)

ENGINE IMMOBILISER SYSTEM (1UZ-FE)

J14

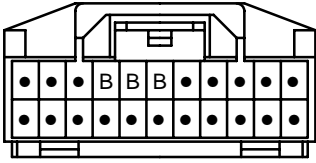

(Hint : See Page 7)

R7

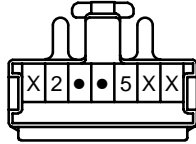

T6
BLACK

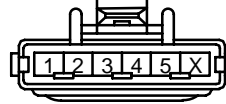

U1

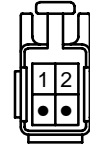

ENGINE IMMOBILISER SYSTEM (2JZ-GE)

FROM POWER SOURCE SYSTEM (SEE PAGE 60)

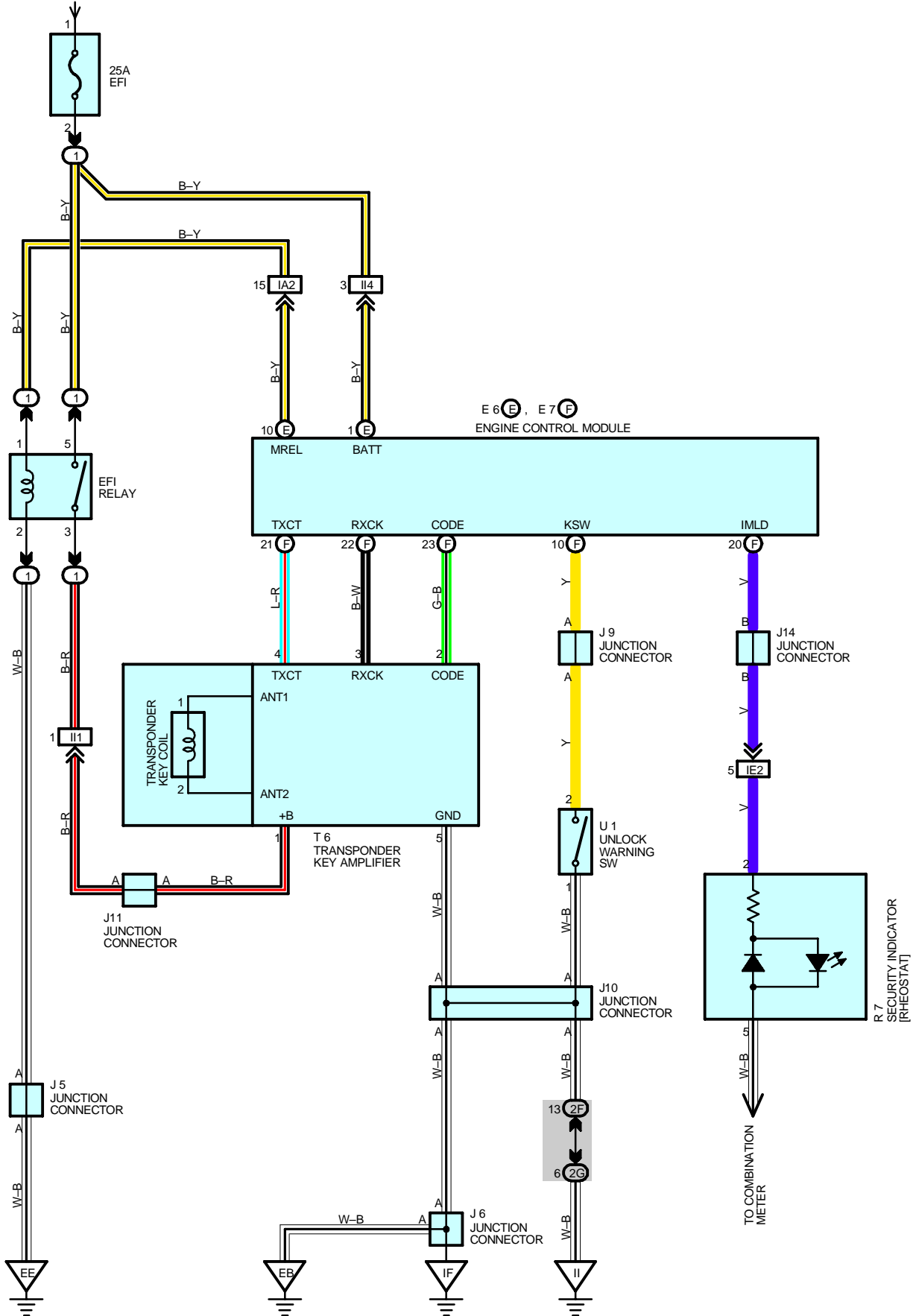

SERVICE HINTS

EFI RELAY

5-3 : Closed with the ignition SW at **ON** position

U1 UNLOCK WARNING SW

1-2 : Closed with the ignition key in cylinder

○ : PARTS LOCATION

Code	See Page	Code	See Page	Code	See Page	
E6	E	38 (2JZ-GE)	J9	41	R7	41
E7	F	38 (2JZ-GE)	J10	41	T6	41
J5		39 (2JZ-GE)	J11	41	U1	41
J6		41	J14	41		

○ : RELAY BLOCKS

Code	See Page	Relay Blocks (Relay Block Location)
1	22	Engine Room No.1 R/B (Engine Compartment Right)

○ : JUNCTION BLOCK AND WIRE HARNESS CONNECTOR

Code	See Page	Junction Block and Wire Harness (Connector Location)
2F	28	Cowl Wire and Passenger Side J/B (Right Kick Panel)
2G	29	

□ : CONNECTOR JOINING WIRE HARNESS AND WIRE HARNESS

Code	See Page	Joining Wire Harness and Wire Harness (Connector Location)
IA2	50	Engine Room Main Wire and Cowl Wire (Near the Driver Side J/B)
IE2	50	Instrument Panel Wire and Cowl Wire (Left Side of the Steering Column)
II1	52	Engine Room Main Wire and Cowl Wire (Near the Passenger Side R/B)
II4		

▽ : GROUND POINTS

Code	See Page	Ground Points Location
EB	48 (2JZ-GE)	Left Fender
EE	48 (2JZ-GE)	Under the ABS & TRAC & VSC Actuator
IF	50	Left Kick Panel
II	50	Right Side of the Cowl Panel

E6 (E)

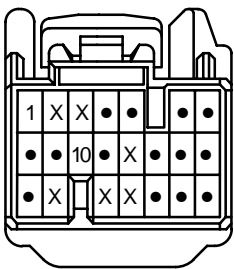

E7 (F)

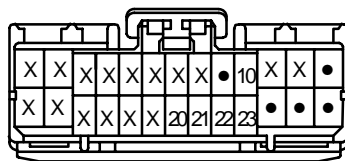

**J5
BLUE**



(Hint : See Page 7)

J6

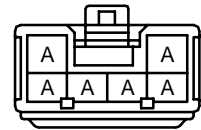

(Hint : See Page 7)

J9

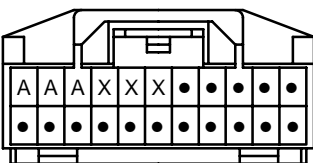

(Hint : See Page 7)

**J10
ORANGE**

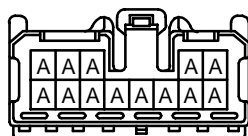

(Hint : See Page 7)

**J11
GRAY**

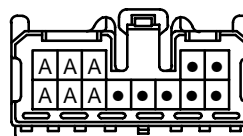

(Hint : See Page 7)

ENGINE IMMOBILISER SYSTEM (2JZ-GE)

J14

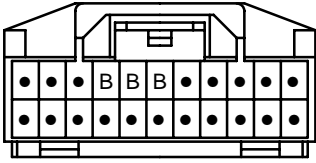

(Hint : See Page 7)

R7

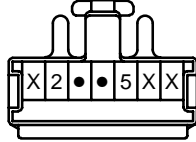

T6
BLACK

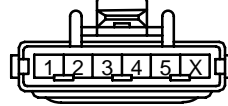

U1

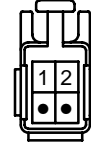

FOG LIGHT

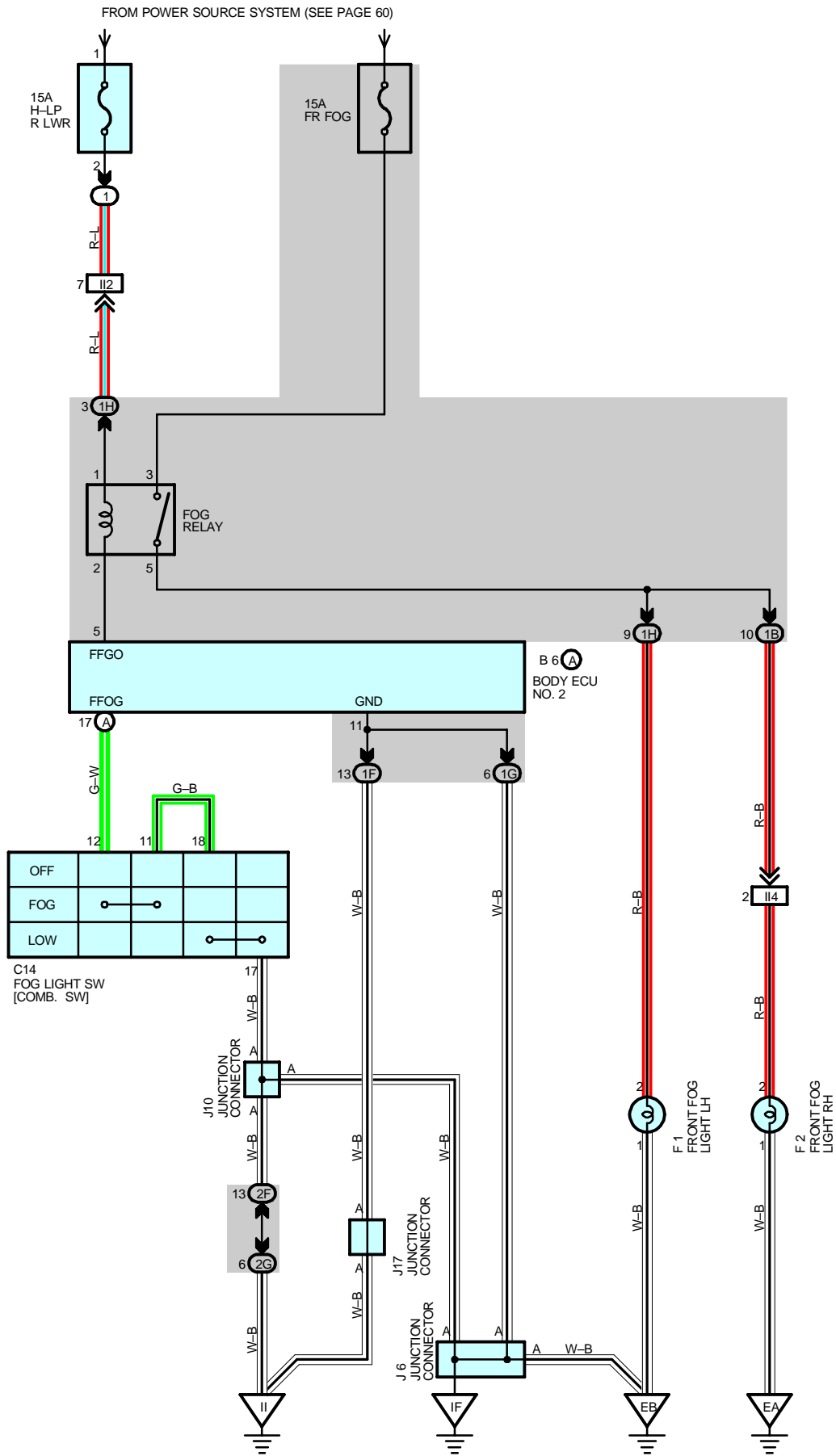

SERVICE HINTS

FOG RELAY

3-5 : Closed with dimmer SW at **LOW** position and fog light SW on

○ : PARTS LOCATION

Code	See Page	Code	See Page	Code	See Page	
B6	A	40	F1	38 (2JZ-GE)	J6	41
C14	40	F2	36 (1UZ-FE)	J10	41	
F1	36 (1UZ-FE)		38 (2JZ-GE)	J17	41	

○ : RELAY BLOCKS

Code	See Page	Relay Blocks (Relay Block Location)
1	22	Engine Room No.1 R/B (Engine Compartment Right)

○ : JUNCTION BLOCK AND WIRE HARNESS CONNECTOR

Code	See Page	Junction Block and Wire Harness (Connector Location)
1B	26	Cowl Wire and Driver Side J/B (Left Kick Panel)
1F		
1G	27	
1H		
2F	28	Cowl Wire and Passenger Side J/B (Right Kick Panel)
2G	29	

□ : CONNECTOR JOINING WIRE HARNESS AND WIRE HARNESS

Code	See Page	Joining Wire Harness and Wire Harness (Connector Location)
II2	52	Engine Room Main Wire and Cowl Wire (Near the Passenger Side R/B)
II4		

▽ : GROUND POINTS

Code	See Page	Ground Points Location
EA	46 (1UZ-FE)	Right Fender
	48 (2JZ-GE)	
EB	46 (1UZ-FE)	Left Fender
	48 (2JZ-GE)	
IF	50	Left Kick Panel
II	50	Right Side of the Cowl Panel

B6 (A)

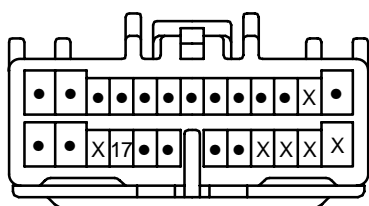

C14

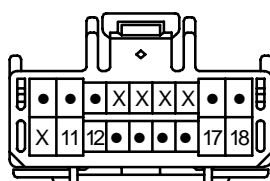

F1
BROWN



F2
BROWN



J6

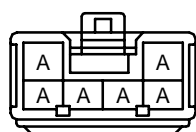

(Hint : See Page 7)

J10
ORANGE

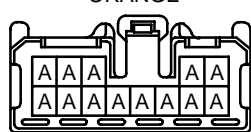

(Hint : See Page 7)

J17

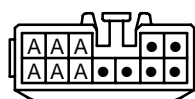

(Hint : See Page 7)

FUEL LID OPENER

FROM POWER SOURCE SYSTEM (SEE PAGE 60)

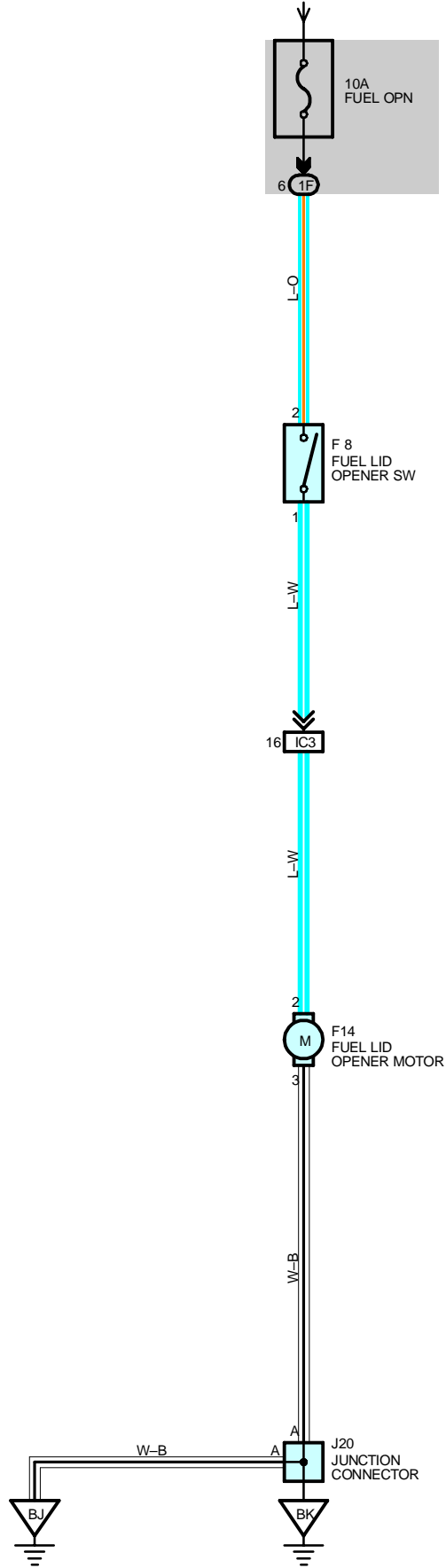

SERVICE HINTS

F8 FUEL LID OPENER SW

2-1 : Closed with fuel lid opener SW on

○ : PARTS LOCATION

Code	See Page	Code	See Page	Code	See Page
F8	40	F14	42	J20	42

○ : JUNCTION BLOCK AND WIRE HARNESS CONNECTOR

Code	See Page	Junction Block and Wire Harness (Connector Location)
1F	26	Cowl Wire and Driver Side J/B (Left Kick Panel)

□ : CONNECTOR JOINING WIRE HARNESS AND WIRE HARNESS

Code	See Page	Joining Wire Harness and Wire Harness (Connector Location)
IC3	50	Floor No.2 Wire and Cowl Wire (Left Kick Panel)

▽ : GROUND POINTS

Code	See Page	Ground Points Location
BJ	54	Rear Floor Partition Panel LH
BK	54	Quarter Panel LH

F8
GREEN

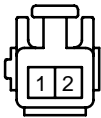

F14
BLACK

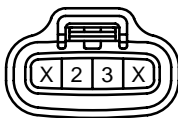

J20

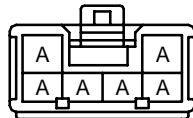

(Hint : See Page 7)

GARAGE DOOR OPENER

FROM POWER SOURCE SYSTEM (SEE PAGE 60)

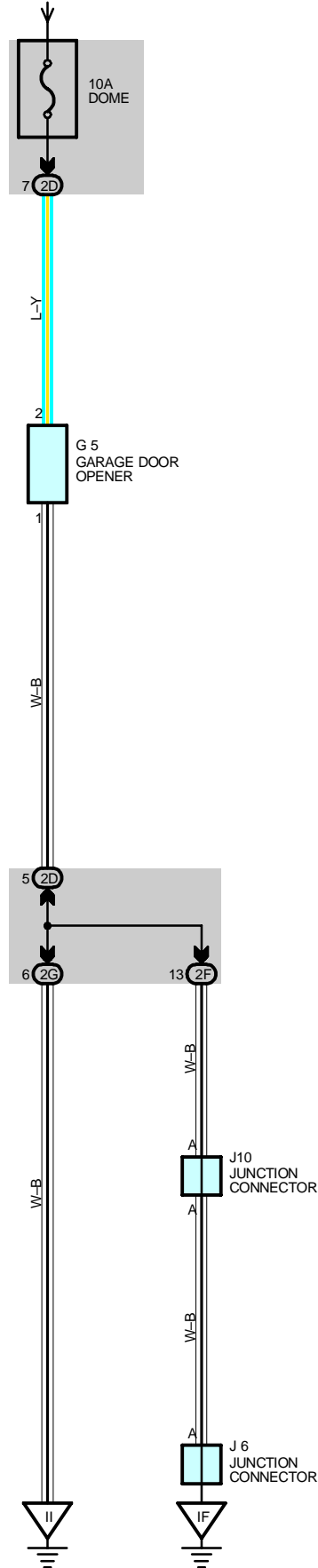

SERVICE HINTS

G5 GARAGE DOOR OPENER

2-GROUND : Always approx. 12 volts

1-GROUND : Always continuity

○ : PARTS LOCATION

Code	See Page	Code	See Page	Code	See Page
G5	42	J6	41	J10	41

○ : JUNCTION BLOCK AND WIRE HARNESS CONNECTOR

Code	See Page	Junction Block and Wire Harness (Connector Location)
2D	28	Roof Wire and Passenger Side J/B (Right Kick Panel)
2F	28	Cowl Wire and Passenger Side J/B (Right Kick Panel)
2G	29	

▽ : GROUND POINTS

Code	See Page	Ground Points Location
IF	50	Left Kick Panel
II	50	Right Side of the Cowl Panel

G5

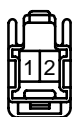

J6

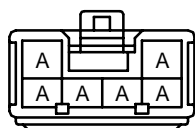

(Hint : See Page 7)

J10
ORANGE

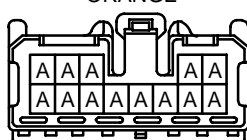

(Hint : See Page 7)

HEADLIGHT (w/ DAYTIME RUNNING LIGHT)

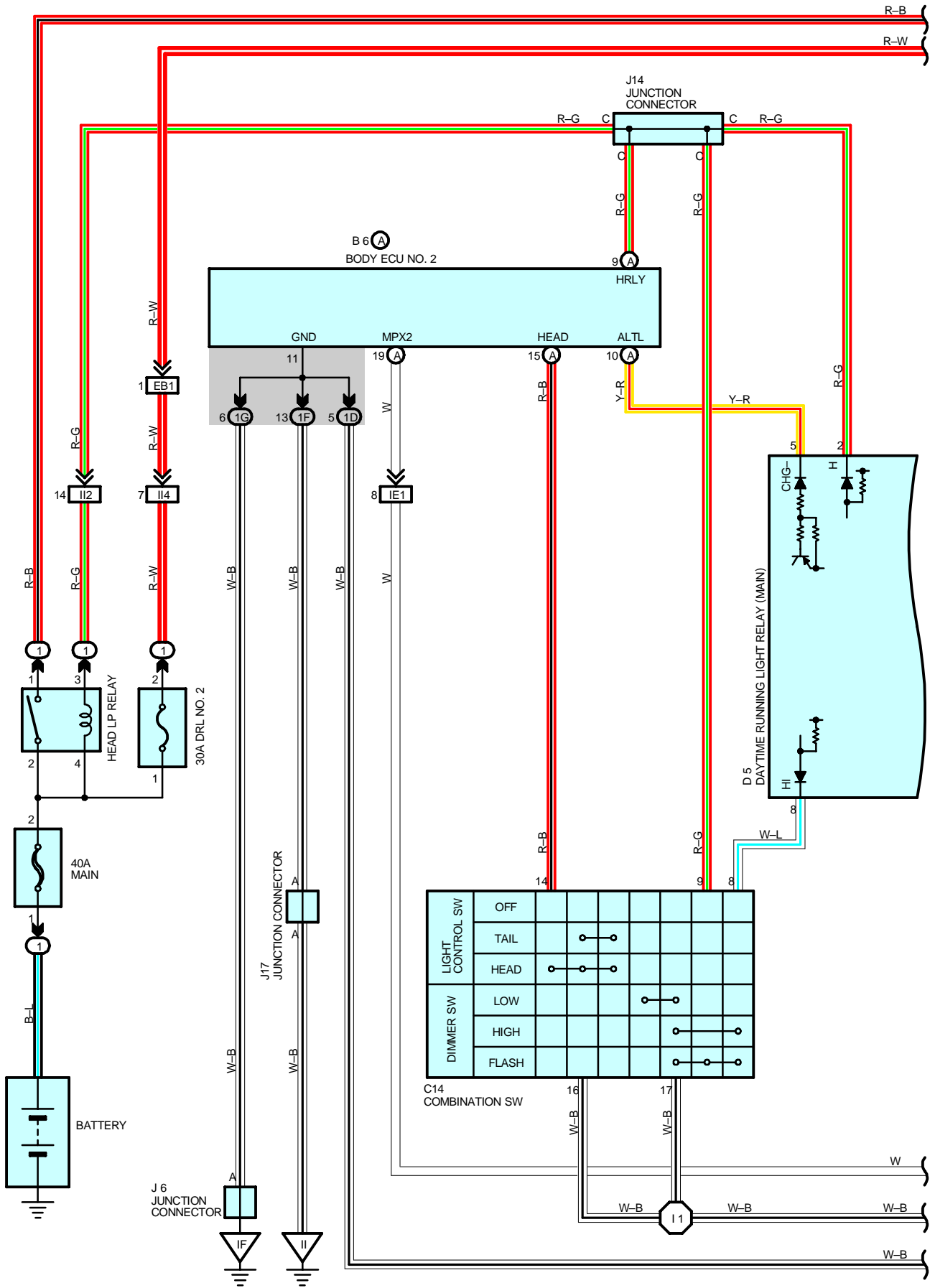

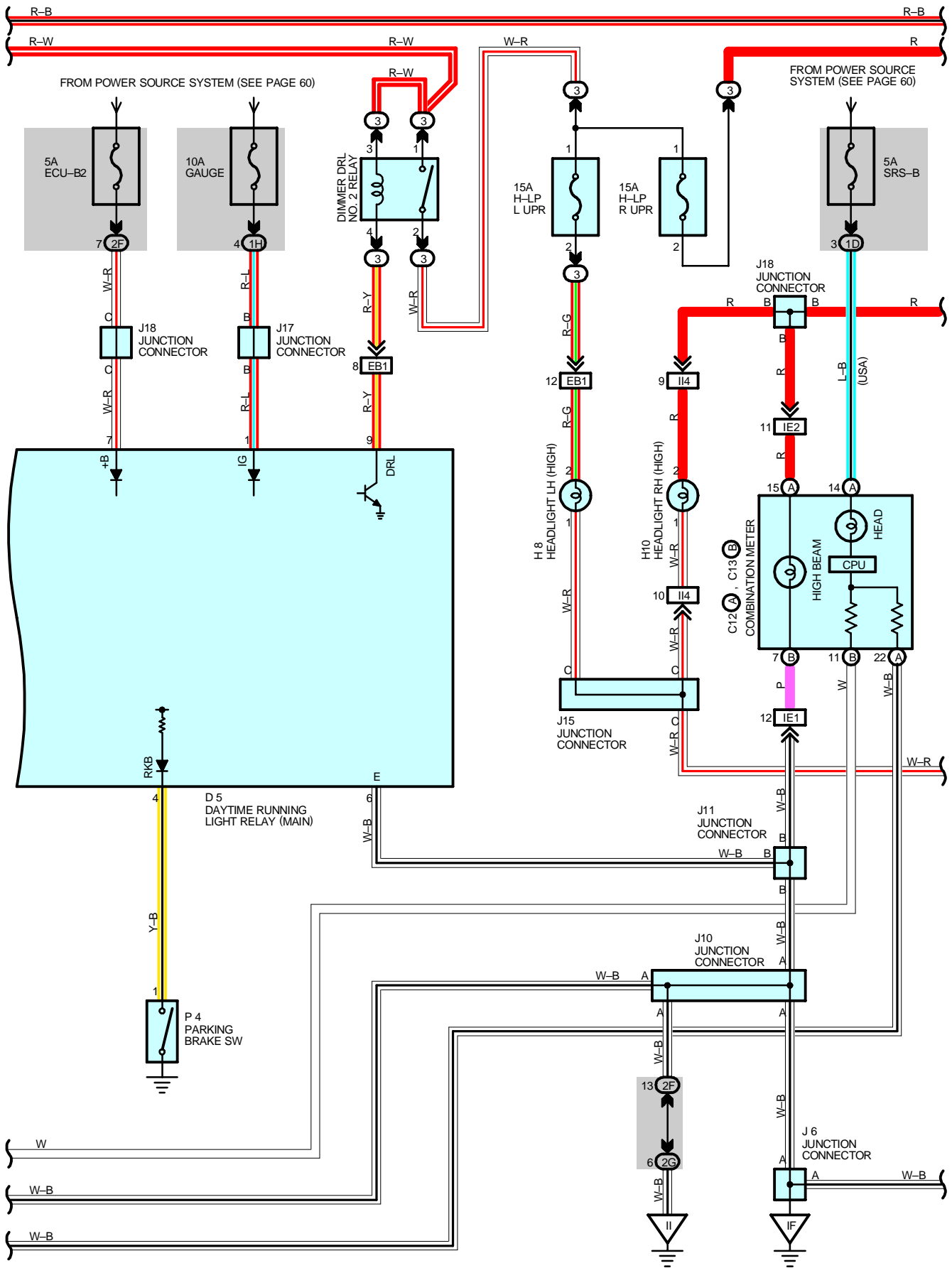

HEADLIGHT (w/ DAYTIME RUNNING LIGHT)

- * 1 : 1UZ-FE
- * 2 : 2JZ-GE
- * 3 : HID TYPE
- * 4 : EXCEPT HID TYPE

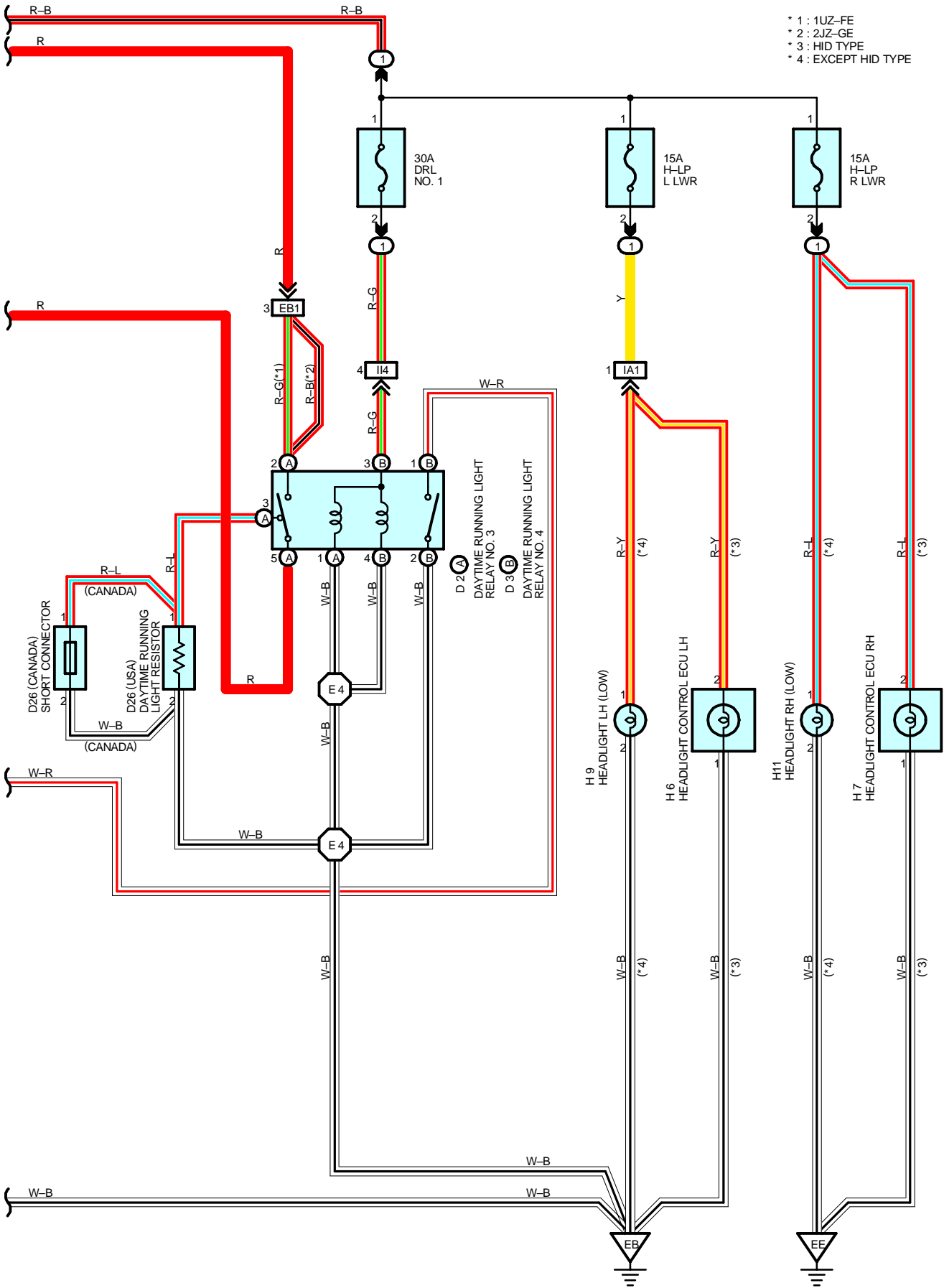

SYSTEM OUTLINE

1. DAYTIME RUNNING LIGHT OPERATION

When the engine is started, the generator signal is input from the body ECU No.2 to TERMINAL 5 of the daytime running light relay (Main). At this time, when the parking brake pedal is depressed (The parking brake SW is on), the relay is not activated and the daytime running light system does not function. When the parking brake pedal is released (The parking brake SW is off), the signal is input to TERMINAL 4 of the daytime running light relay (Main). This activates the relay to turn on the DIMMER DRL NO.2 relay. The current flows from the battery into the MAIN fuse to DRL NO.2 fuse to DIMMER DRL NO.2 relay (Point side) to H-LP L UPR fuse to TERMINAL 2 of the headlight LH (High) to TERMINAL 1 to TERMINAL 1 of the headlight RH (High) to TERMINAL 2 to TERMINAL (A) 5 of the daytime running light relay No.3 to TERMINAL (A) 3 to TERMINAL 1 of the daytime running light resistor (USA) or short connector (Canada) to TERMINAL 2 to GROUND. The headlights light up more dimly than usual as the engine is started.

Once the daytime running light system has been activated, the headlights are remained lit even though the parking brake pedal is depressed (The parking brake SW is on). Even if the engine is stopped and the generator signal is cut off with the ignition SW set at ON, the headlights are remained lit. When the ignition SW is turned from ON to OFF, the daytime running light system is stopped and the headlights go off. If the engine is started with the parking brake pedal released, the daytime running light system starts functioning and the headlights light up as the engine is started.

2. HEADLIGHT OPERATION

* Light control SW is set at HEAD.

When the light control SW is set to HEAD position, the signal is input to TERMINAL 15 of the body ECU No.2. This activates the body ECU No.2 and turns on the HEAD LP relay. When the signal is input to TERMINAL 2 of the daytime running light relay (Main), the daytime running light system is deactivated and headlights LH and RH (High) go off. At this time, the current flows from the battery into the MAIN fuse to HEAD LP relay (Point side) to H-LP L LWR and H-LP R LWR fuse to TERMINAL 1 of the headlights LH and RH (Low) (except HID type) or TERMINAL 2 of the HEADLIGHT CONTROL ECU LH and RH (HID type) to TERMINAL 2 (except HID type) or TERMINAL 1 (HID type) to GROUND, to turn on the headlights (Low beam).

* Dimmer SW is set at HIGH.

When the light control SW is set to HEAD position, the current flows into the daytime running light relay No.3 and No.4 (Coil side) to turn on the relay as the headlights (Low beam) light up. At this time, when the dimmer SW is set to HIGH position, the signal is input to TERMINAL 8 of the daytime running light relay (Main). This activates the DIMMER DRL NO.2 relay to flow the current from the battery into the MAIN fuse to DRL NO.2 fuse to DIMMER DRL NO.2 relay (Point side) to headlights LH and RH (High) to daytime running light relay No.4 (Point side) to GROUND, to turn on the headlights (High and low) and high beam indicator light at the same time.

* Dimmer SW is set at FLASH.

When the dimmer SW is set to FLASH position, the current flows from the battery into the MAIN fuse, HEAD LP relay (Coil side) to TERMINAL 9 of the combination SW to TERMINAL 17 to GROUND in that order to turn on the HEAD LP relay.

Additionally, the signal is input to TERMINAL 8 of the daytime running light relay (Main) to activate the relay and turn on the DIMMER DRL NO.2 relay. In the same manner as the dimmer SW set at HIGH position, the headlights (High and low) and high beam indicator light are turned on at the same time.

SERVICE HINTS

HEAD LP RELAY

1-2 : Closed with light control SW at **HEAD** position or dimmer SW at **FLASH** position

DIMMER DRL NO.2 RELAY

1-2 : Closed with daytime running light operation

Closed with light control SW at **HEAD** position and dimmer SW at **HIGH** position

Closed with dimmer SW at **FLASH** position

D2 (A), D3 (B) DAYTIME RUNNING LIGHT RELAY NO.3, NO.4

(A) 2-(A) 5, (B) 1-(B) 2 : Closed with light control SW at **HEAD** position and dimmer SW at **HIGH** position or dimmer SW at **FLASH** position

C14 COMBINATION SW

14-16 : Closed with light control SW at **HEAD** position

9-17 : Closed with dimmer SW at **FLASH** position

8-17 : Closed with dimmer SW at **HIGH** or **FLASH** position

B6 (A) BODY ECU NO.2

9-GROUND : Approx. **12** volts

15-GROUND : Continuity with light control SW at **HEAD** position

HEADLIGHT (w/ DAYTIME RUNNING LIGHT)

: PARTS LOCATION

Code		See Page	Code	See Page	Code	See Page
B6	A	40	H6	36 (1UZ-FE)	H11	38 (2JZ-GE)
C12	A	40		38 (2JZ-GE)	J6	41
C13	B	40	H7	36 (1UZ-FE)	J10	41
C14		40		38 (2JZ-GE)	J11	41
D2	A	36 (1UZ-FE)	H8	36 (1UZ-FE)	J14	41
		38 (2JZ-GE)		38 (2JZ-GE)	J15	41
D3	B	36 (1UZ-FE)	H9	36 (1UZ-FE)	J17	41
		38 (2JZ-GE)		38 (2JZ-GE)	J18	41
D5		40	H10	36 (1UZ-FE)	P4	41
D26		36 (1UZ-FE)		38 (2JZ-GE)		
			38 (2JZ-GE)	H11	36 (1UZ-FE)	

: RELAY BLOCKS

Code	See Page	Relay Blocks (Relay Block Location)
1	22	Engine Room No.1 R/B (Engine Compartment Right)
3	24	Engine Room No.3 R/B (Engine Compartment Left)

: JUNCTION BLOCK AND WIRE HARNESS CONNECTOR

Code	See Page	Junction Block and Wire Harness (Connector Location)
1D	26	Instrument Panel Wire and Driver Side J/B (Left Kick Panel)
1F	26	Cowl Wire and Driver Side J/B (Left Kick Panel)
1G	27	
1H		
2F	28	
2G	29	Cowl Wire and Passenger Side J/B (Right Kick Panel)

: CONNECTOR JOINING WIRE HARNESS AND WIRE HARNESS

Code	See Page	Joining Wire Harness and Wire Harness (Connector Location)
EB1	46 (1UZ-FE)	Cowl Wire and Relay Block Wire (Inside of the Engine Room No.3 R/B)
	48 (2JZ-GE)	
IA1	50	Engine Room Main Wire and Cowl Wire (Near the Driver Side J/B)
IE1	50	Instrument Panel Wire and Cowl Wire (Left Side of the Steering Column)
IE2		
II2	52	Engine Room Main Wire and Cowl Wire (Near the Passenger Side R/B)
II4		

: GROUND POINTS

Code	See Page	Ground Points Location
EB	46 (1UZ-FE)	Left Fender
	48 (2JZ-GE)	
EE	46 (1UZ-FE)	Under the ABS & TRAC & VSC Actuator
	48 (2JZ-GE)	
IF	50	Left Kick Panel
II	50	Right Side of the Cowl Panel

: SPLICE POINTS

Code	See Page	Wire Harness with Splice Points	Code	See Page	Wire Harness with Splice Points
E4	46 (1UZ-FE)	Cowl Wire	I1	52	Cowl Wire
	48 (2JZ-GE)				

B6 (A)

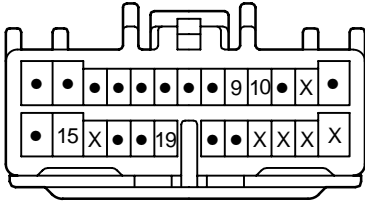

C12 (A)

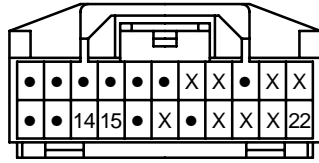

C13 (B)

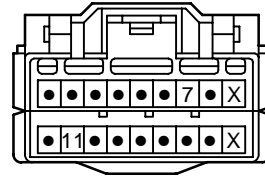

C14

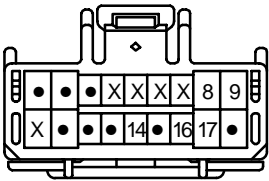

**D2 (A)
GRAY**

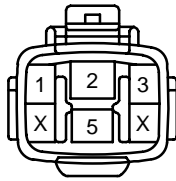

**D3 (B)
GRAY**



**D5
GRAY**

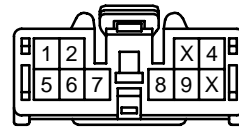

**D26
GRAY**

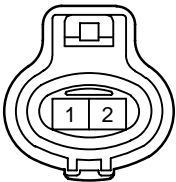

H6



H7



**H8
BLACK**



**H9
BROWN**



**H10
BLACK**



**H11
BROWN**



J6

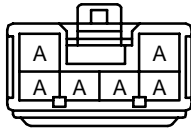

(Hint : See Page 7)

**J10
ORANGE**

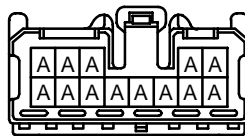

(Hint : See Page 7)

**J11
GRAY**

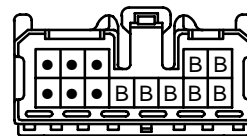

(Hint : See Page 7)

J14

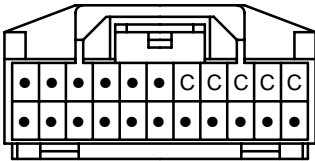

(Hint : See Page 7)

J15

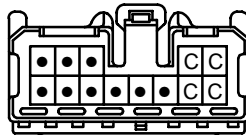

(Hint : See Page 7)

J17



(Hint : See Page 7)

**J18
BLUE**

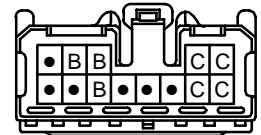

(Hint : See Page 7)

P4



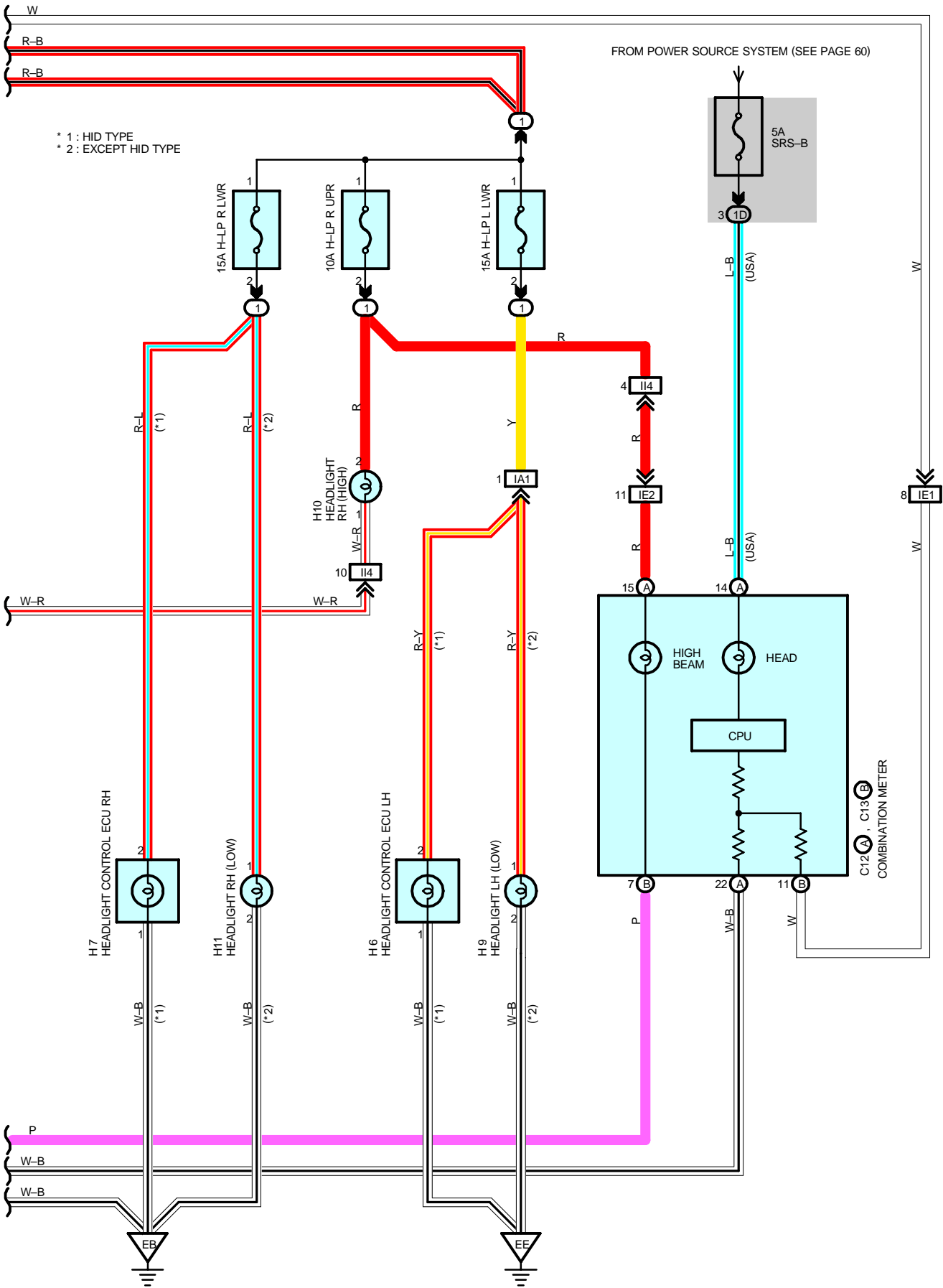

HEADLIGHT (w/o DAYTIME RUNNING LIGHT)

SERVICE HINTS

HEAD LP RELAY

1-2 : Closed with light control SW at **HEAD** position or dimmer SW at **FLASH** position

C14 COMBINATION SW

14-16 : Closed with light control SW at **HEAD** position

8-17 : Closed with dimmer SW at **HIGH** or **FLASH** position

9-17 : Closed with dimmer SW at **FLASH** position

○ : PARTS LOCATION

Code	See Page	Code	See Page	Code	See Page	
B6	A	40	H7	38 (2JZ-GE)	H11	
C12	A	40	H8	36 (1UZ-FE)		36 (1UZ-FE)
C13	B	40		38 (2JZ-GE)	J6	41
C14		40	H9	36 (1UZ-FE)	J10	41
H6		36 (1UZ-FE)		38 (2JZ-GE)	J14	41
		38 (2JZ-GE)	H10	36 (1UZ-FE)	J15	41
H7		36 (1UZ-FE)		38 (2JZ-GE)	J17	41

○ : RELAY BLOCKS

Code	See Page	Relay Blocks (Relay Block Location)
1	22	Engine Room No.1 R/B (Engine Compartment Right)

○ : JUNCTION BLOCK AND WIRE HARNESS CONNECTOR

Code	See Page	Junction Block and Wire Harness (Connector Location)
1D	26	Instrument Panel Wire and Driver Side J/B (Left Kick Panel)
1F	26	Cowl Wire and Driver Side J/B (Left Kick Panel)
1G	27	
2F	28	Cowl Wire and Passenger Side J/B (Right Kick Panel)
2G	29	

□ : CONNECTOR JOINING WIRE HARNESS AND WIRE HARNESS

Code	See Page	Joining Wire Harness and Wire Harness (Connector Location)
IA1	50	Engine Room Main Wire and Cowl Wire (Near the Driver Side J/B)
IE1	50	Instrument Panel Wire and Cowl Wire (Left Side of the Steering Column)
IE2		
II2	52	Engine Room Main Wire and Cowl Wire (Near the Passenger Side R/B)
II4		

▽ : GROUND POINTS

Code	See Page	Ground Points Location
EB	46 (1UZ-FE)	Left Fender
	48 (2JZ-GE)	
EE	46 (1UZ-FE)	Under the ABS & TRAC & VSC Actuator
	48 (2JZ-GE)	
IF	50	Left Kick Panel
II	50	Right Side of the Cowl Panel

○ : SPLICE POINTS

Code	See Page	Wire Harness with Splice Points	Code	See Page	Wire Harness with Splice Points
I1	52	Cowl Wire			

B6 (A)

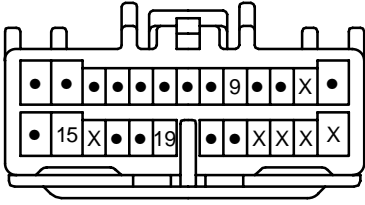

C12 (A)

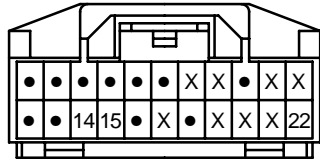

C13 (B)

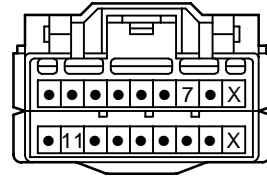

C14

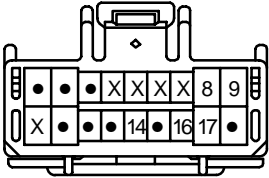

H6



H7



**H8
BLACK**



**H9
BROWN**



**H10
BLACK**



**H11
BROWN**



J6

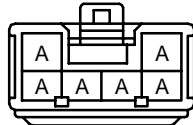

(Hint : See Page 7)

**J10
ORANGE**

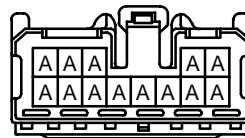

(Hint : See Page 7)

J14

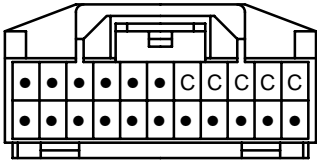

(Hint : See Page 7)

J15

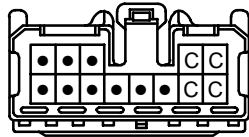

(Hint : See Page 7)

J17



(Hint : See Page 7)

HEADLIGHT BEAM LEVEL CONTROL

FROM POWER SOURCE SYSTEM (SEE PAGE 60)

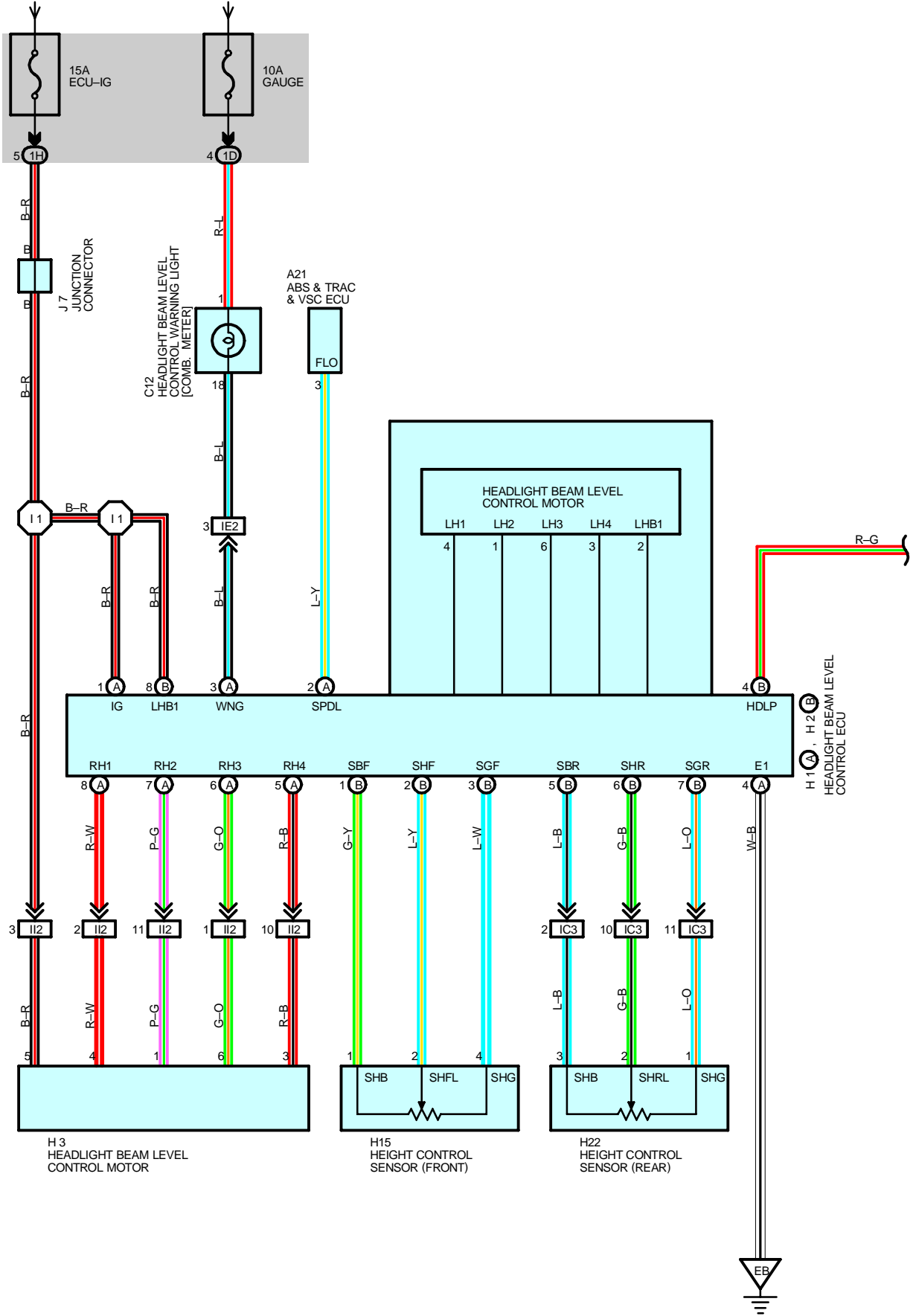

FROM POWER SOURCE SYSTEM (SEE PAGE 60)

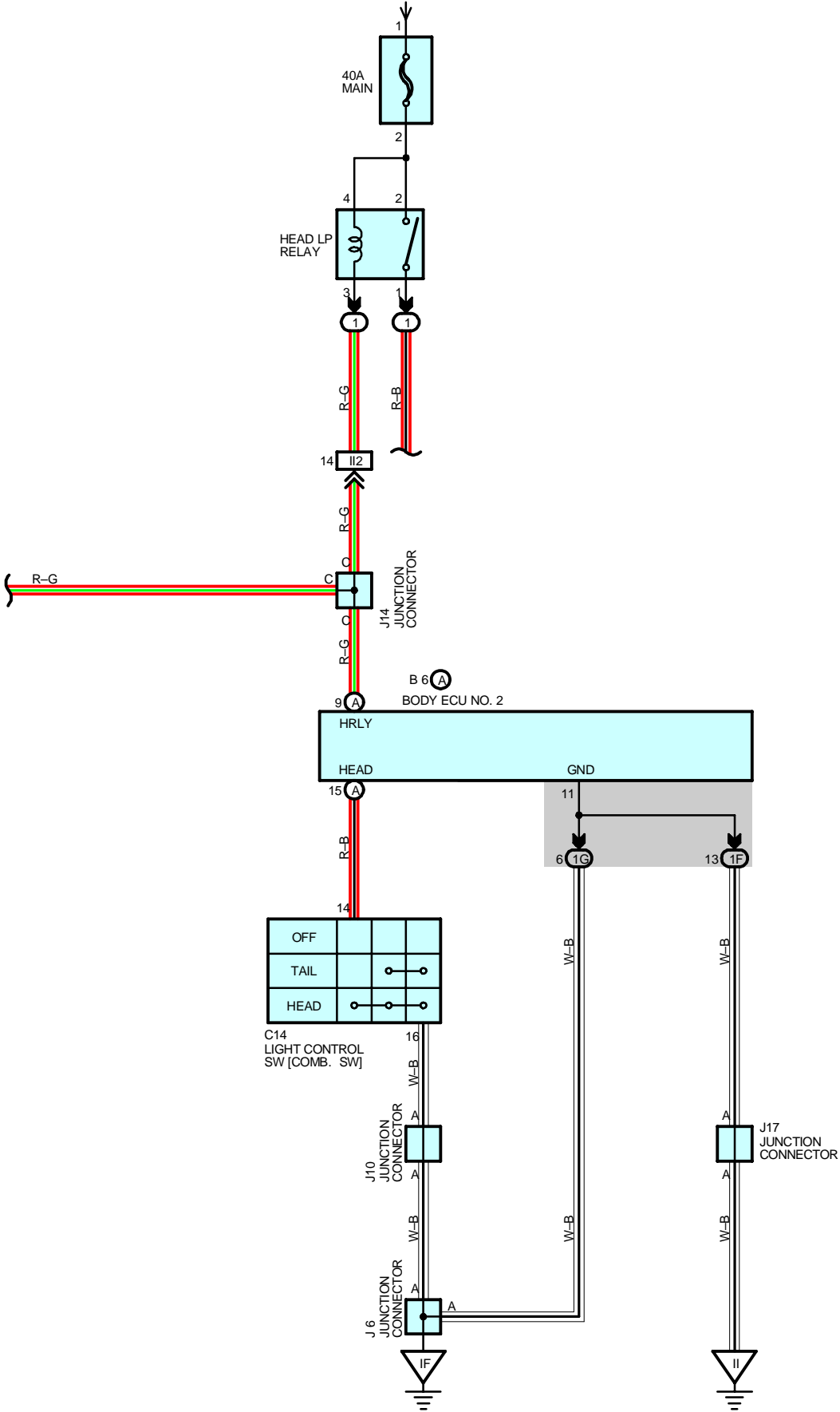

HEADLIGHT BEAM LEVEL CONTROL

SYSTEM OUTLINE

This system calculates changes in the illuminating angle from changes in the vehicle height and axle distance based on the information on the vehicle height detected by the height sensors installed at the front and rear of the vehicle and information on the vehicle speed and acceleration output from the VSC system to reversely operate the reflector by the obtained illuminating angle through actuators in order to always keep the beam axis constant.
If an error occurs in this system, the headlight beam level control warning light in the combination meter lights up to warn the driver.

SERVICE HINTS

H1 (A), H2 (B) HEADLIGHT BEAM LEVEL CONTROL ECU

- (A) 1, (B) 8-GROUND : Approx. 12 volts with ignition SW at **ON** or **ST** position
 (A) 4-GROUND : Always continuity
 (B) 4-GROUND : Approx. 12 volts with light control SW at **HEAD** position

C14 LIGHT CONTROL SW [COMB. SW]

14-16 : Closed with light control SW at **HEAD** position

○ : PARTS LOCATION

Code	See Page	Code	See Page	Code	See Page	
A21	40	H2	B	36 (1UZ-FE)	H22	42
B6	A			40	38 (2JZ-GE)	J6
C12	40	H3	36 (1UZ-FE)	J7	41	
C14	40		38 (2JZ-GE)	J10	41	
H1	A	H15	36 (1UZ-FE)	J14	41	
			38 (2JZ-GE)	J17	41	

○ : RELAY BLOCKS

Code	See Page	Relay Blocks (Relay Block Location)
1	22	Engine Room No.1 R/B (Engine Compartment Right)

○ : JUNCTION BLOCK AND WIRE HARNESS CONNECTOR

Code	See Page	Junction Block and Wire Harness (Connector Location)
1D	26	Instrument Panel Wire and Driver Side J/B (Left Kick Panel)
1F	26	Cowl Wire and Driver Side J/B (Left Kick Panel)
1G	27	
1H		

□ : CONNECTOR JOINING WIRE HARNESS AND WIRE HARNESS

Code	See Page	Joining Wire Harness and Wire Harness (Connector Location)
IC3	50	Floor No.2 Wire and Cowl Wire (Left Kick Panel)
IE2	50	Instrument Panel Wire and Cowl Wire (Left Side of the Steering Column)
II2	52	Engine Room Main Wire and Cowl Wire (Near the Passenger Side R/B)

▽ : GROUND POINTS

Code	See Page	Ground Points Location
EB	46 (1UZ-FE)	Left Fender
	48 (2JZ-GE)	
IF	50	Left Kick Panel
II	50	Right Side of the Cowl Panel

○ : SPLICE POINTS

Code	See Page	Wire Harness with Splice Points	Code	See Page	Wire Harness with Splice Points
I1	52	Cowl Wire			

A21

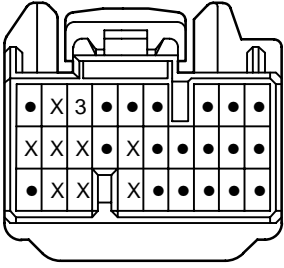

B6 (A)

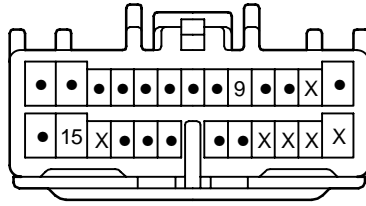

C12

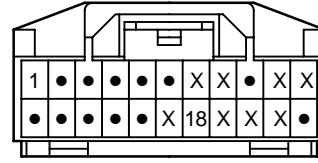

C14

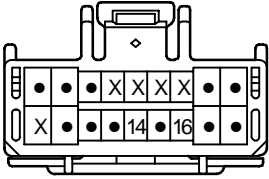

H1 (A)
GRAY

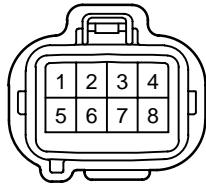

H2 (B)
BLACK



H3
BLACK

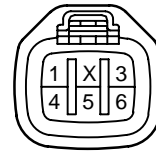

H15
DARK GRAY



H22

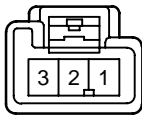

J6

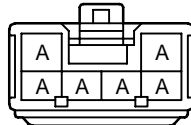

(Hint : See Page 7)

J7
GRAY

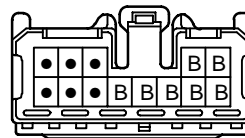

(Hint : See Page 7)

J10
ORANGE

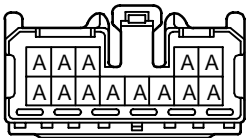

(Hint : See Page 7)

J14

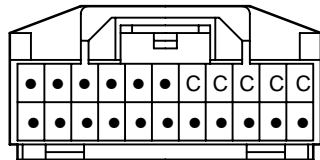

(Hint : See Page 7)

J17



(Hint : See Page 7)

HEADLIGHT CLEANER

FROM POWER SOURCE SYSTEM (SEE PAGE 60)

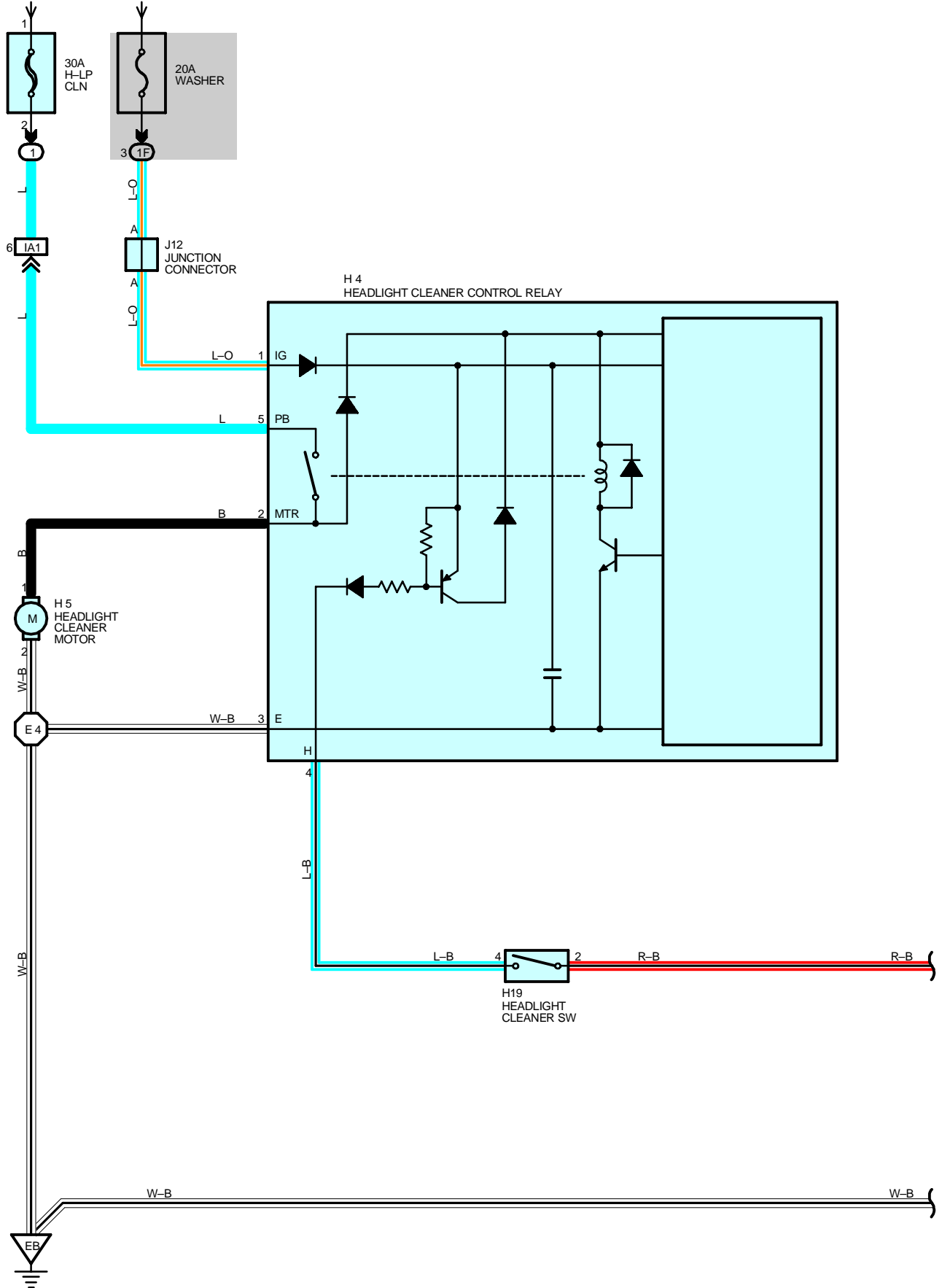

FROM POWER SOURCE SYSTEM (SEE PAGE 60)

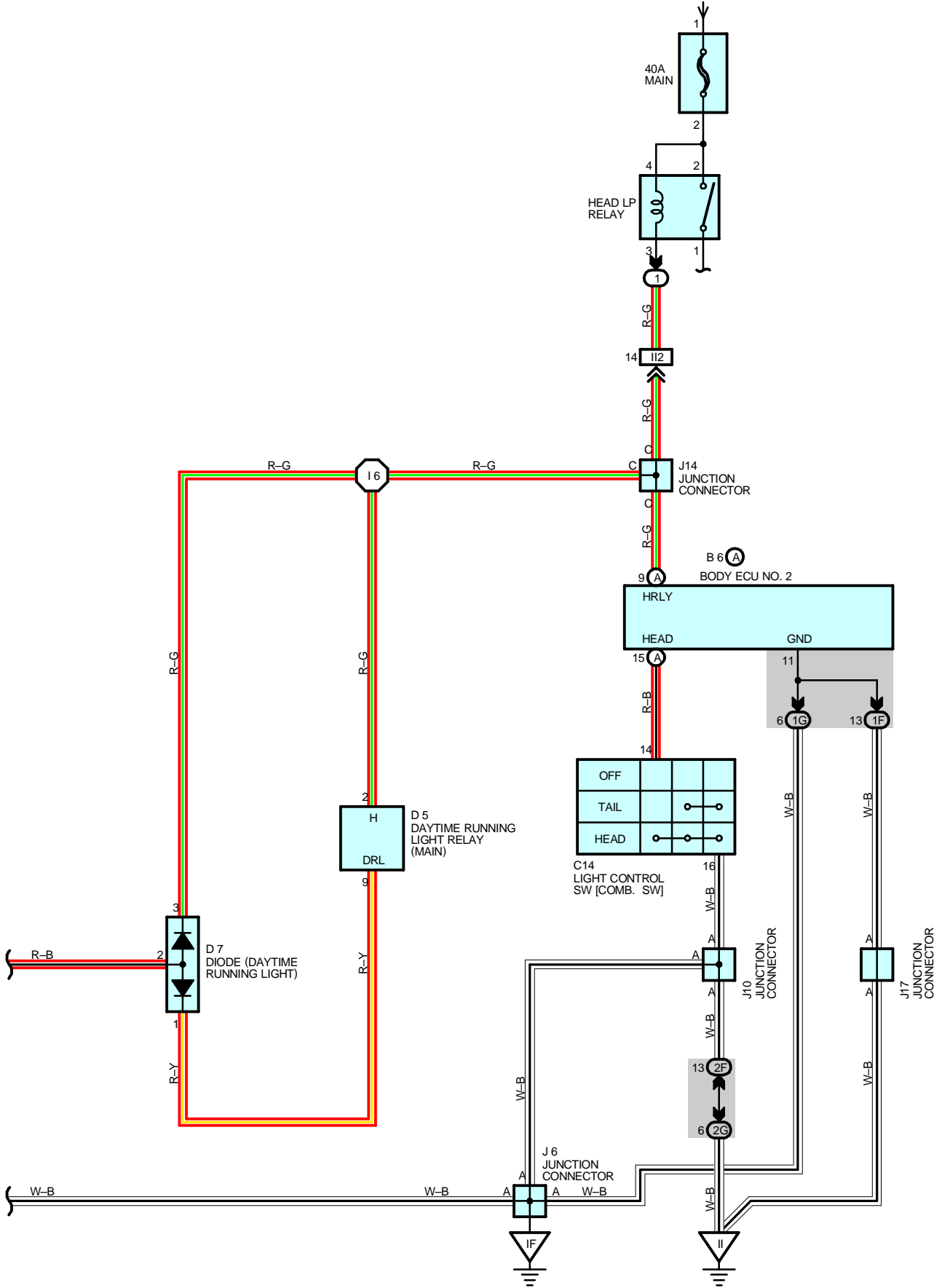

HEADLIGHT CLEANER

SERVICE HINTS

H4 HEADLIGHT CLEANER CONTROL RELAY

5-2 : Closed with ignition SW at **ON** position, light control SW at **HEAD** position and headlight cleaner SW on

○ : PARTS LOCATION

Code	See Page	Code	See Page	Code	See Page	
B6	A	40	H4	38 (2JZ-GE)	J10	41
C14	40	H5	36 (1UZ-FE)	J12	41	
D5	40		38 (2JZ-GE)	J14	41	
D7	40	H19	40	J17	41	
H4	36 (1UZ-FE)	J6	41			

○ : RELAY BLOCKS

Code	See Page	Relay Blocks (Relay Block Location)
1	22	Engine Room No.1 R/B (Engine Compartment Right)

○ : JUNCTION BLOCK AND WIRE HARNESS CONNECTOR

Code	See Page	Junction Block and Wire Harness (Connector Location)
1F	26	Cowl Wire and Driver Side J/B (Left Kick Panel)
1G	27	
2F	28	Cowl Wire and Passenger Side J/B (Right Kick Panel)
2G	29	

□ : CONNECTOR JOINING WIRE HARNESS AND WIRE HARNESS

Code	See Page	Joining Wire Harness and Wire Harness (Connector Location)
IA1	50	Engine Room Main Wire and Cowl Wire (Near the Driver Side J/B)
II2	52	Engine Room Main Wire and Cowl Wire (Near the Passenger Side R/B)

▽ : GROUND POINTS

Code	See Page	Ground Points Location
EB	46 (1UZ-FE)	Left Fender
	48 (2JZ-GE)	
IF	50	Left Kick Panel
II	50	Right Side of the Cowl Panel

○ : SPLICE POINTS

Code	See Page	Wire Harness with Splice Points	Code	See Page	Wire Harness with Splice Points
E4	46 (1UZ-FE)	Cowl Wire	I 6	52	Cowl Wire
	48 (2JZ-GE)				

B6 (A)

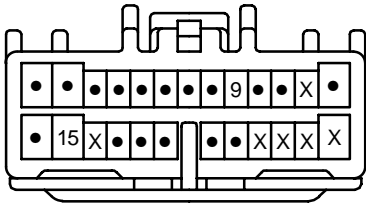

C14

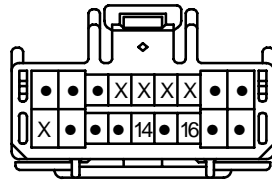

**D5
GRAY**

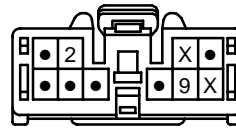

D7

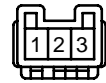

**H4
BLACK**

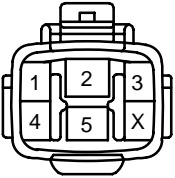

**H5
BLACK**



H19

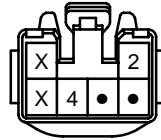

J6

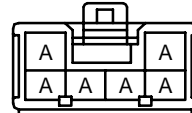

(Hint : See Page 7)

**J10
ORANGE**

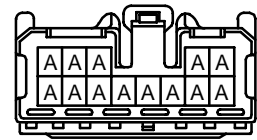

(Hint : See Page 7)

**J12
GRAY**

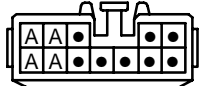

(Hint : See Page 7)

J14

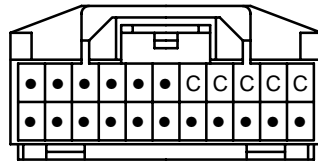

(Hint : See Page 7)

J17



(Hint : See Page 7)

HORN

FROM POWER SOURCE SYSTEM (SEE PAGE 60)

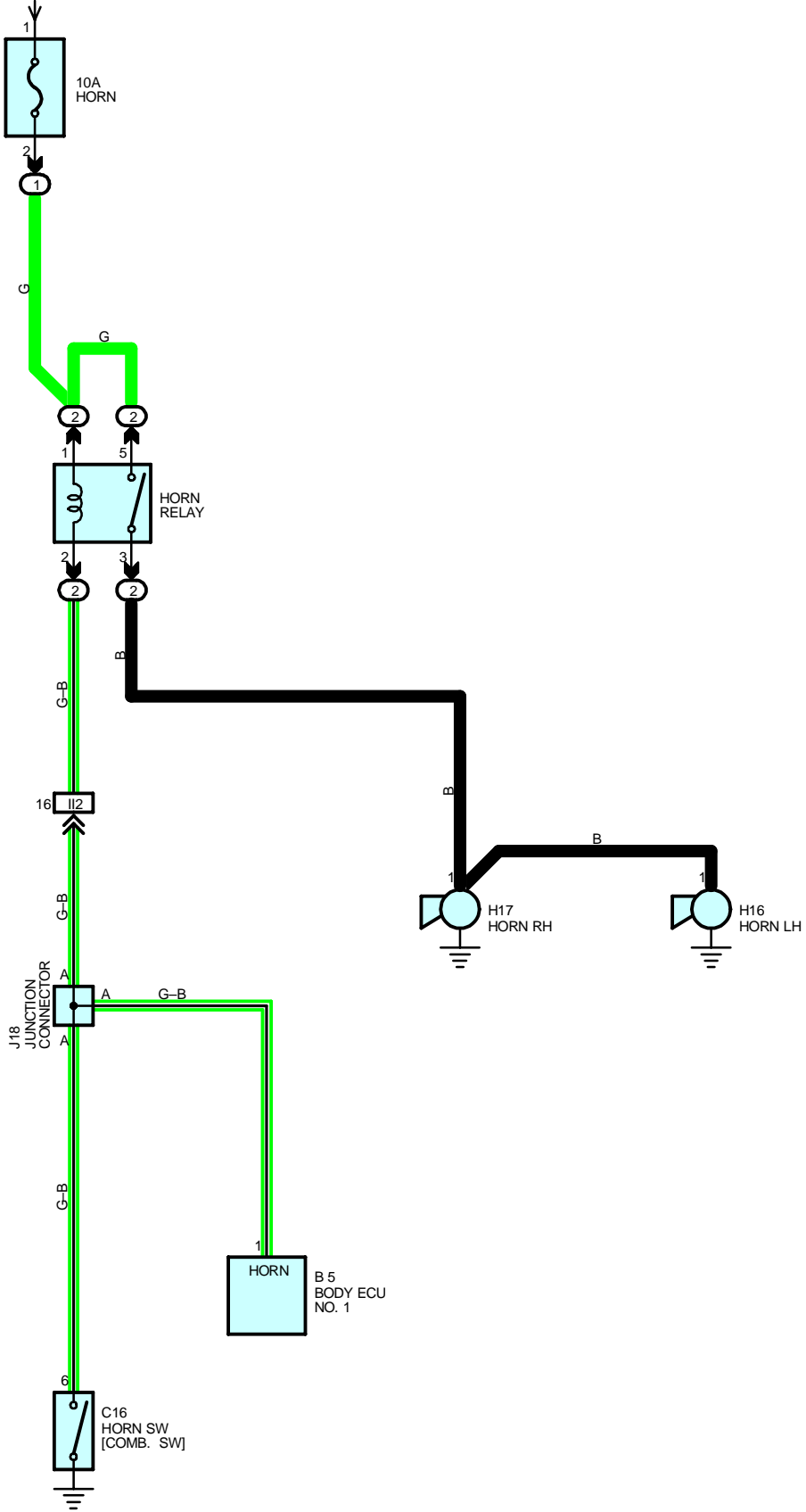

SERVICE HINTS

HORN RELAY

5-3 : Closed horn SW on

○ : PARTS LOCATION

Code	See Page	Code	See Page	Code	See Page
B5	40	H16	38 (2JZ-GE)	J18	41
C16	40	H17	36 (1UZ-FE)		
H16	36 (1UZ-FE)		38 (2JZ-GE)		

○ : RELAY BLOCKS

Code	See Page	Relay Blocks (Relay Block Location)
1	22	Engine Room No.1 R/B (Engine Compartment Right)
2	23	Engine Room No.2 R/B (Engine Compartment Left)

□ : CONNECTOR JOINING WIRE HARNESS AND WIRE HARNESS

Code	See Page	Joining Wire Harness and Wire Harness (Connector Location)
II2	52	Engine Room Main Wire and Cowl Wire (Near the Passenger Side R/B)

B5

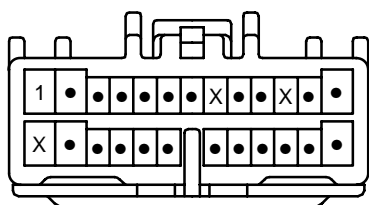

C16
(1UZ-FE) BLACK

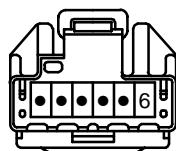

C16
(2JZ-GE) BLACK

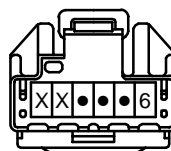

H16
BLACK



H17
BLACK



J18
BLUE

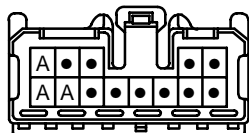

(Hint : See Page 7)

ILLUMINATION

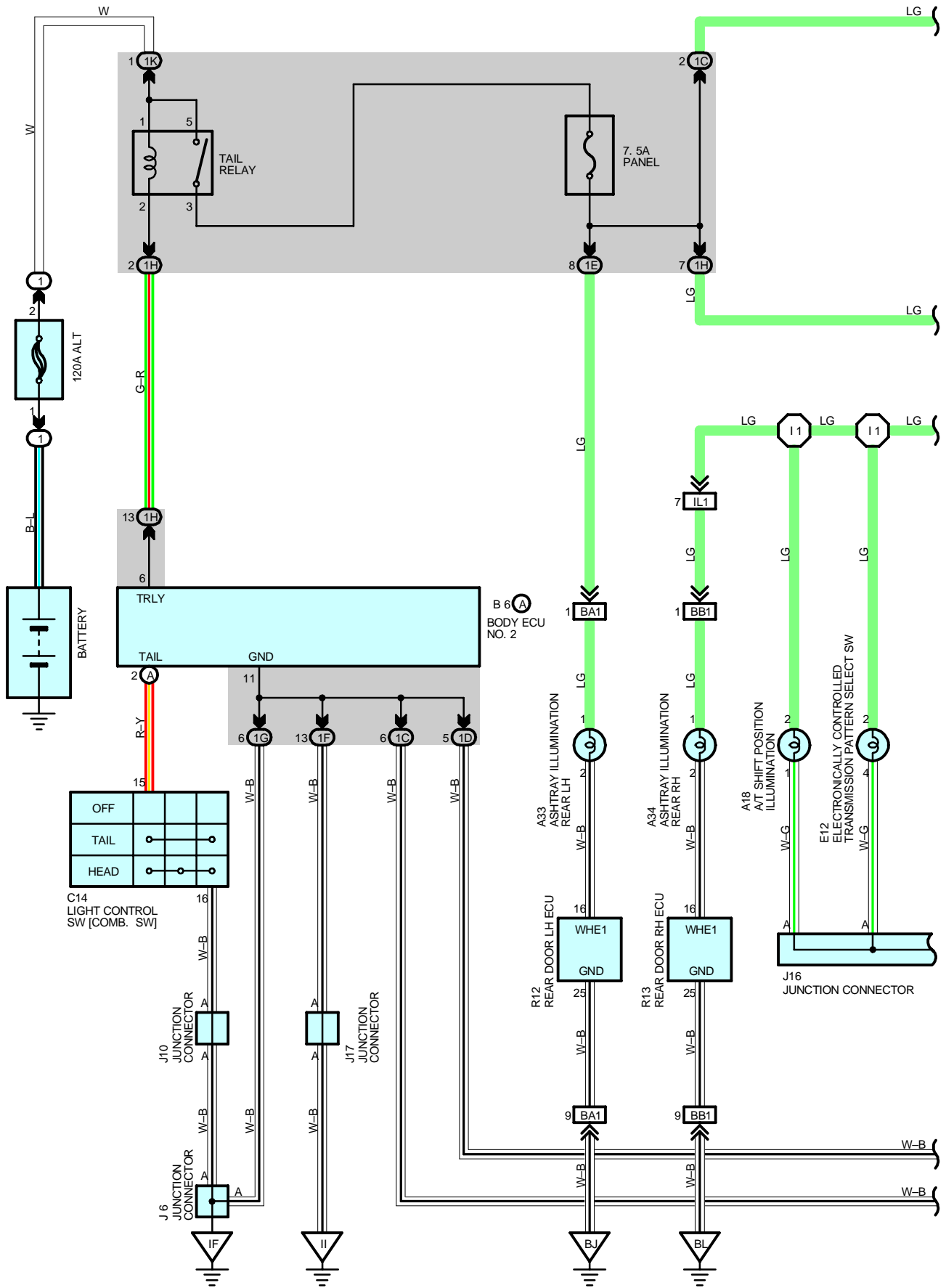

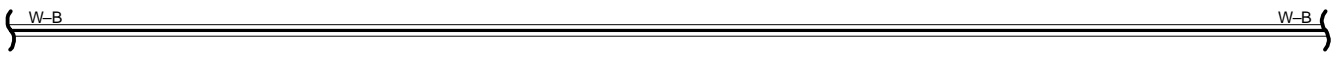
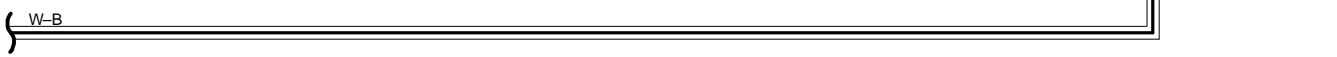
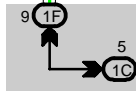
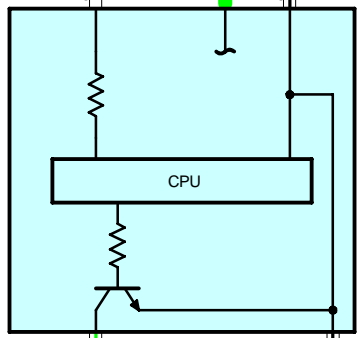
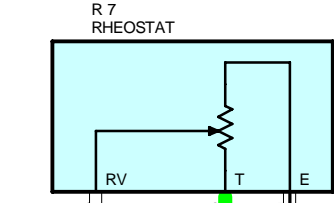
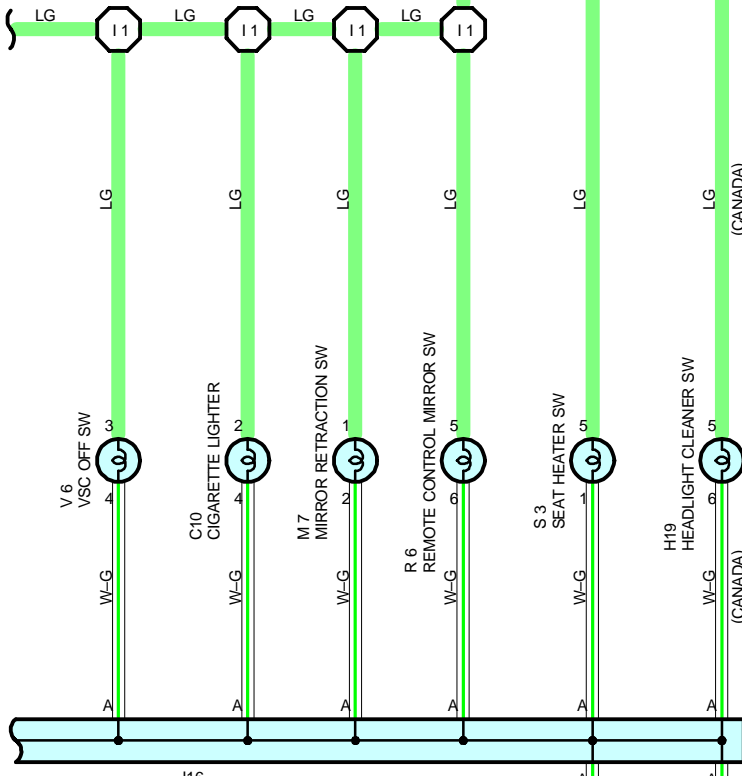

ILLUMINATION

* 1 : NAKAMICHI
 * 2 : EXCEPT NAKAMICHI

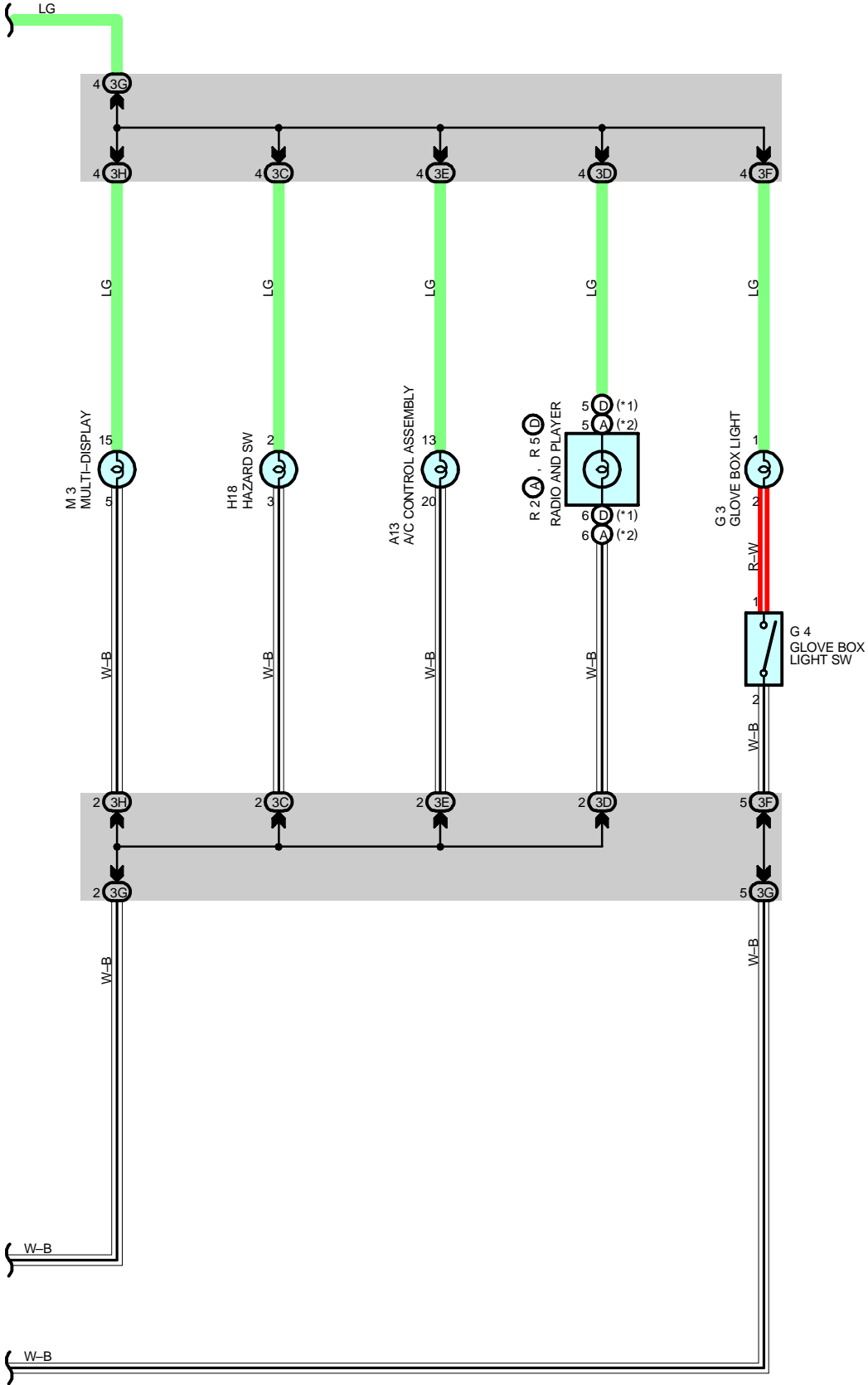

SERVICE HINTS**TAIL RELAY**5-3 : Closed with light control SW at **TAIL** or **HEAD** position**C14 LIGHT CONTROL SW [COMB. SW]**15-16 : Closed with light control SW at **TAIL** or **HEAD** position**○ : PARTS LOCATION**

Code	See Page	Code	See Page	Code	See Page
A13	40	G4	40	R2	A 41
A18	40	H18	40	R5	D 41
A33	42	H19	40	R6	41
A34	42	J6	41	R7	41
B6	A 40	J10	41	R12	43
C10	40	J13	41	R13	43
C12	40	J16	41	S3	41
C14	40	J17	41	V6	41
E12	40	M3	41		
G3	40	M7	41		

○ : RELAY BLOCKS

Code	See Page	Relay Blocks (Relay Block Location)
1	22	Engine Room No.1 R/B (Engine Compartment Right)

○ : JUNCTION BLOCK AND WIRE HARNESS CONNECTOR

Code	See Page	Junction Block and Wire Harness (Connector Location)
1C	26	Instrument Panel Wire and Driver Side J/B (Left Kick Panel)
1D		
1E	26	Floor No.2 Wire and Driver Side J/B (Left Kick Panel)
1F	26	Cowl Wire and Driver Side J/B (Left Kick Panel)
1G	27	
1H		
1K	26	Engine Room Main Wire and Driver Side J/B (Left Kick Panel)
3C	30	Instrument Panel Wire and Instrument Panel J/B (Instrument Panel Reinforcement Center)
3D		
3E		
3F	31	
3G		
3H		

□ : CONNECTOR JOINING WIRE HARNESS AND WIRE HARNESS

Code	See Page	Joining Wire Harness and Wire Harness (Connector Location)
IE2	50	Instrument Panel Wire and Cowl Wire (Left Side of the Steering Column)
IL1	52	Floor No.1 Wire and Cowl Wire (Right Kick Panel)
BA1	54	Rear Door LH Wire and Floor No.2 Wire (Under the Center Pillar LH)
BB1	54	Rear Door RH Wire and Floor No.1 Wire (Under the Center Pillar RH)

▽ : GROUND POINTS

Code	See Page	Ground Points Location
IF	50	Left Kick Panel
II	50	Right Side of the Cowl Panel
BJ	54	Rear Floor Partition Panel LH
BL	54	Rear Floor Partition Panel RH

ILLUMINATION

 : SPLICE POINTS

Code	See Page	Wire Harness with Splice Points	Code	See Page	Wire Harness with Splice Points
I1	52	Cowl Wire			

A13

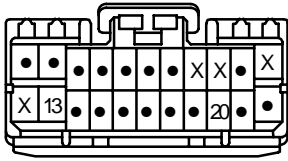

A18



A33
BLACK



A34
BLACK



B6 (A)

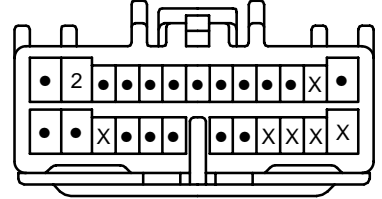

C10
BLACK

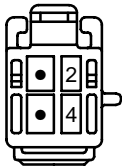

C12

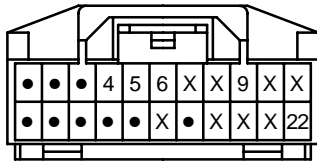

C14

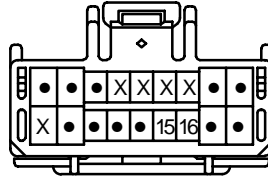

E12
BLACK

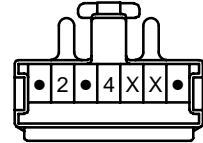

G3



G4
BLACK



H18
BLACK

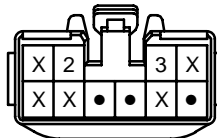

H19

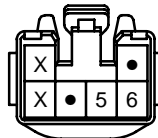

J6

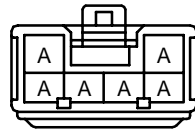

(Hint : See Page 7)

J10
ORANGE

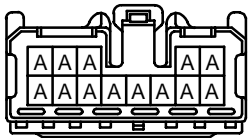

(Hint : See Page 7)

J13

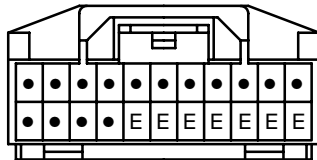

(Hint : See Page 7)

J16



(Hint : See Page 7)

J17



(Hint : See Page 7)

M3
BLUE

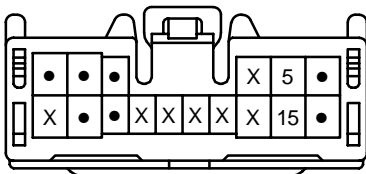

M7
BLUE

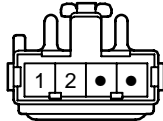

R2 (A)
(Except NAKAMICHI)

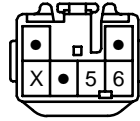

R5 (D)
(NAKAMICHI) ORANGE



R6
BLACK

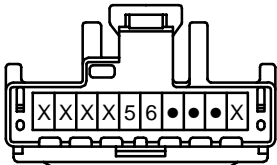

R7

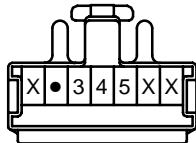

R12

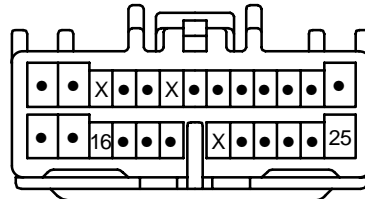

R13

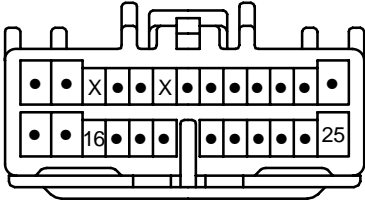

S3

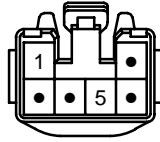

V6

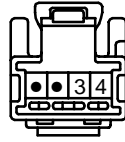

INTERIOR LIGHT

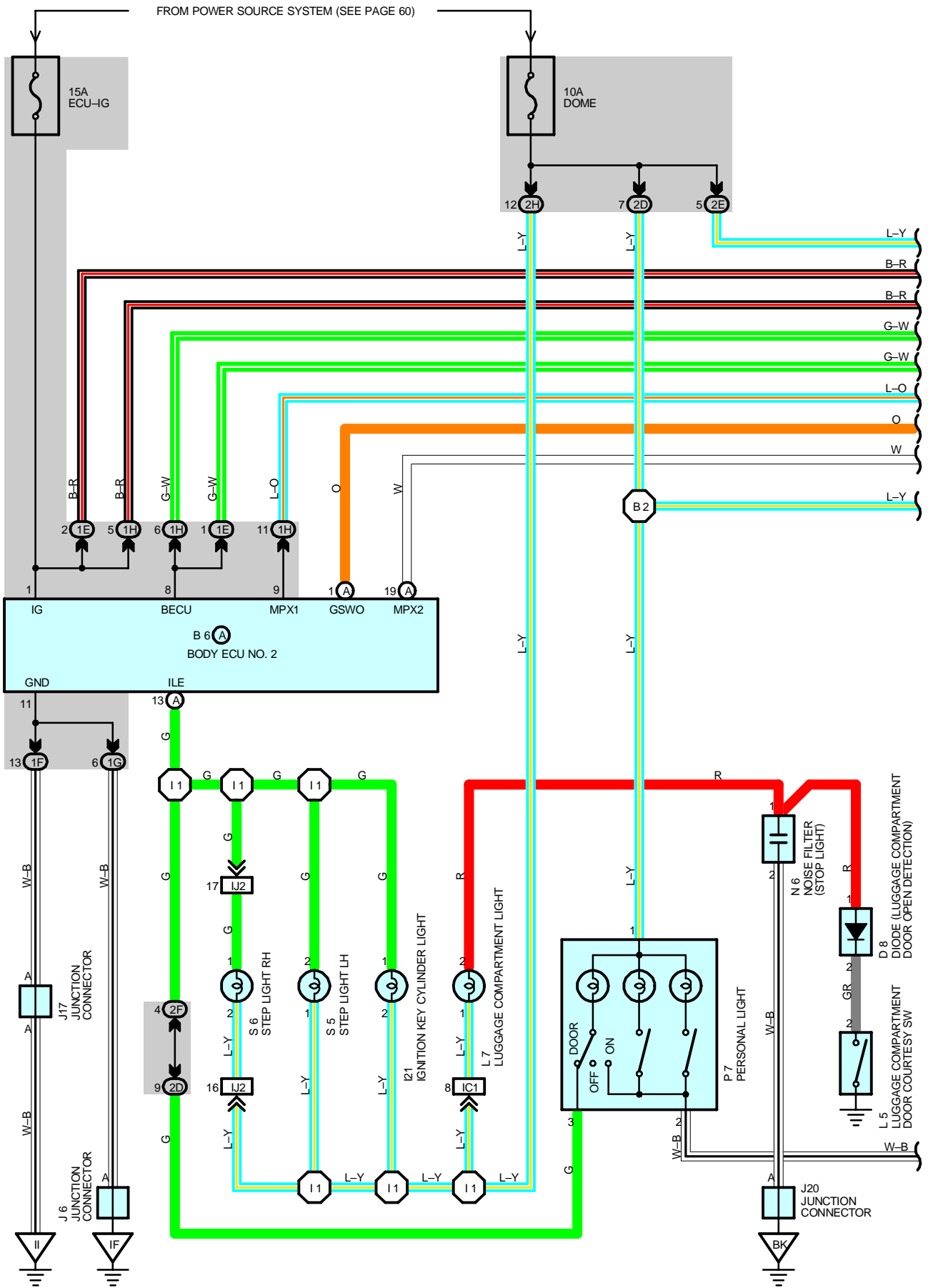

* 1 : W/ LEXUS NAVIGATION SYSTEM
 * 2 : W/O LEXUS NAVIGATION SYSTEM

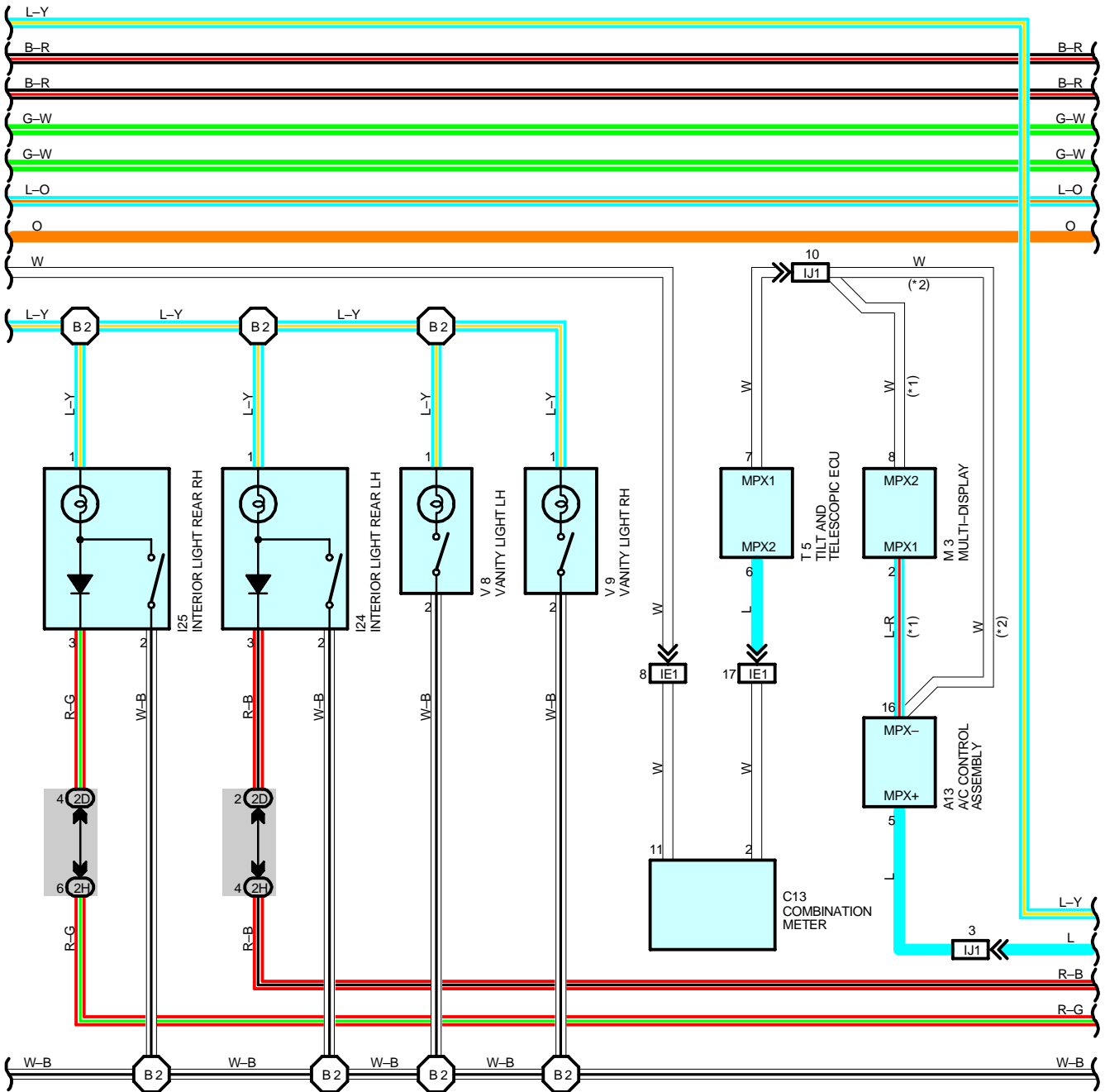

INTERIOR LIGHT

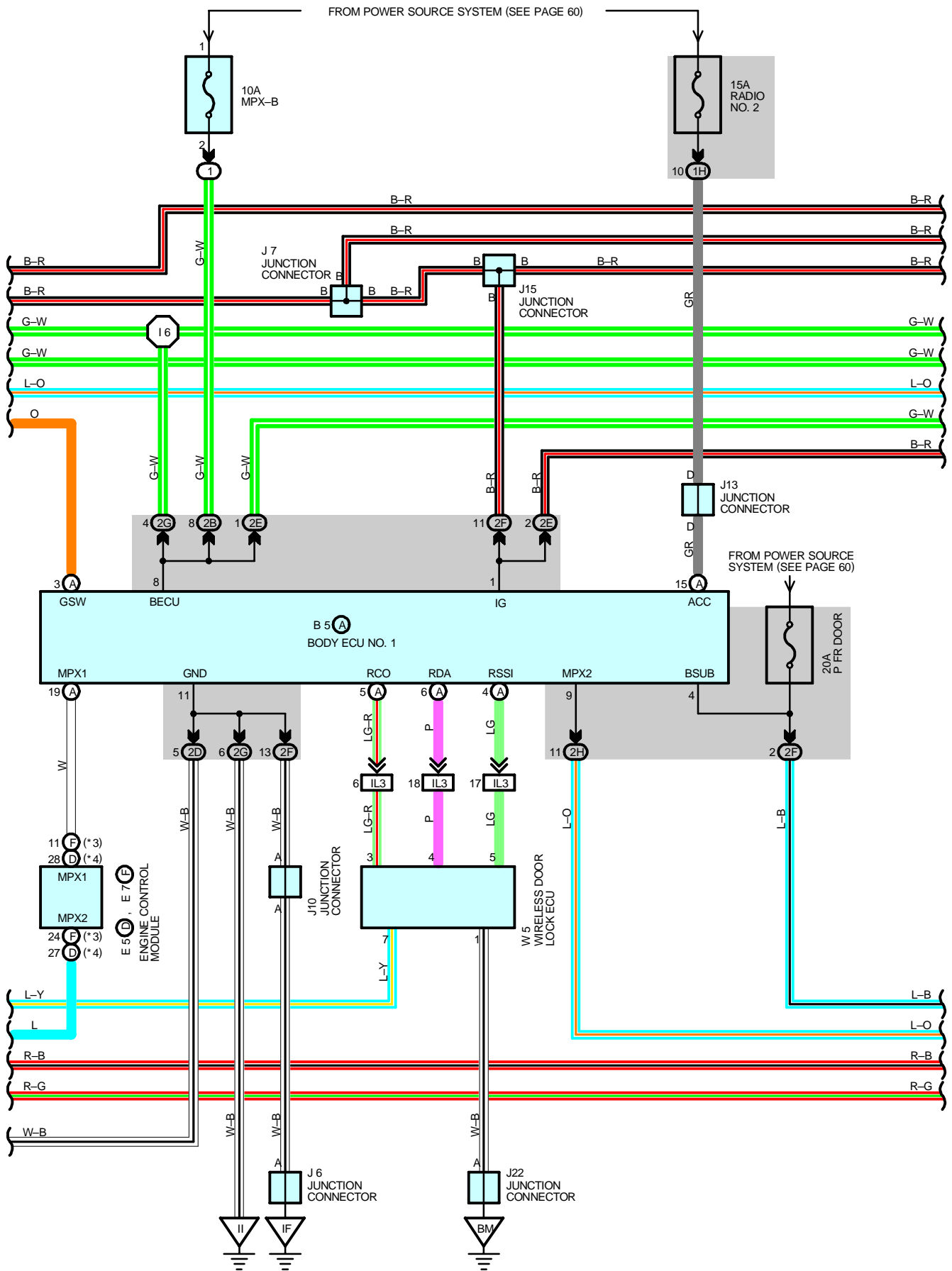

FROM POWER SOURCE SYSTEM (SEE PAGE 60)

* 3 : 1UZ-FE
* 4 : 2JZ-GE

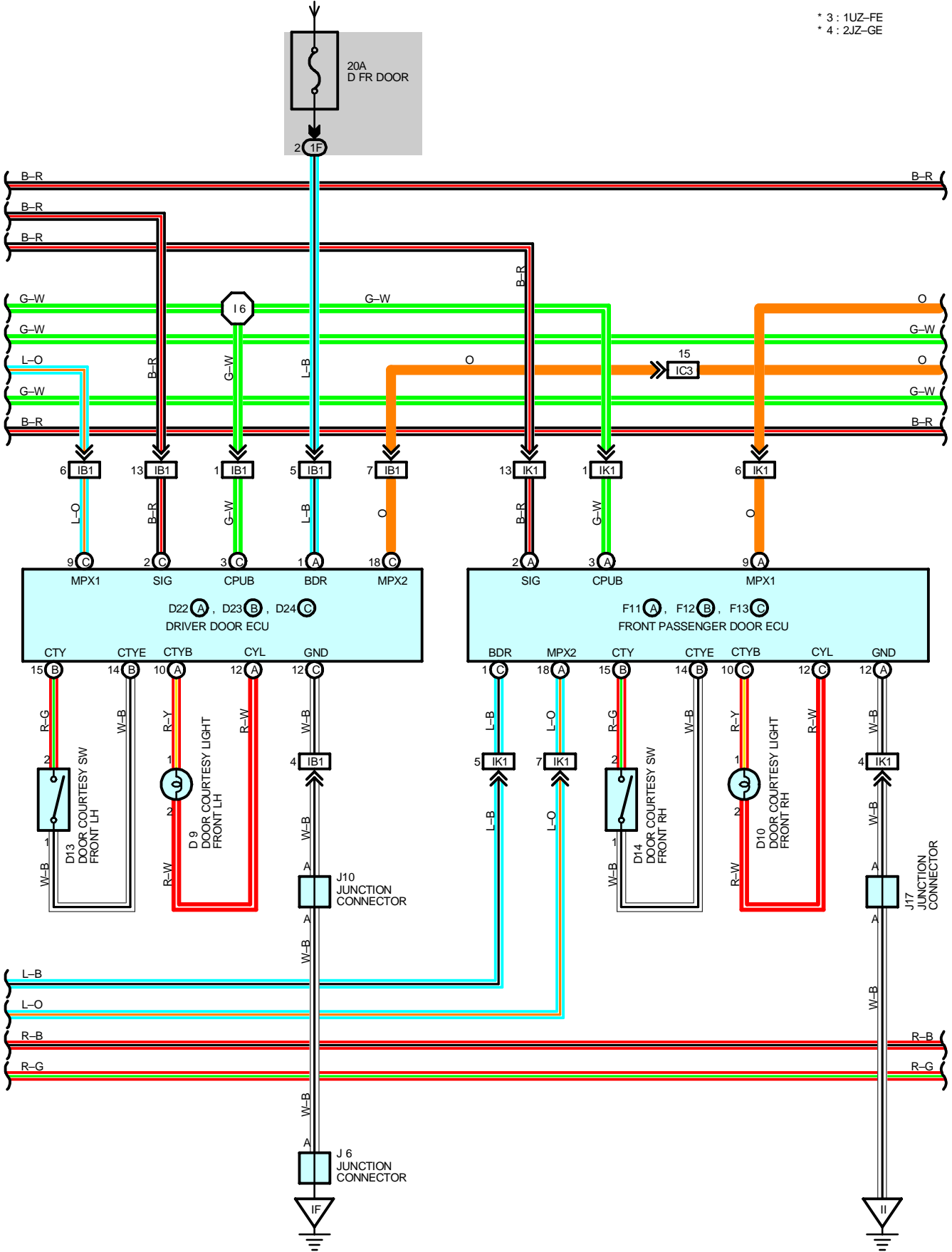

INTERIOR LIGHT

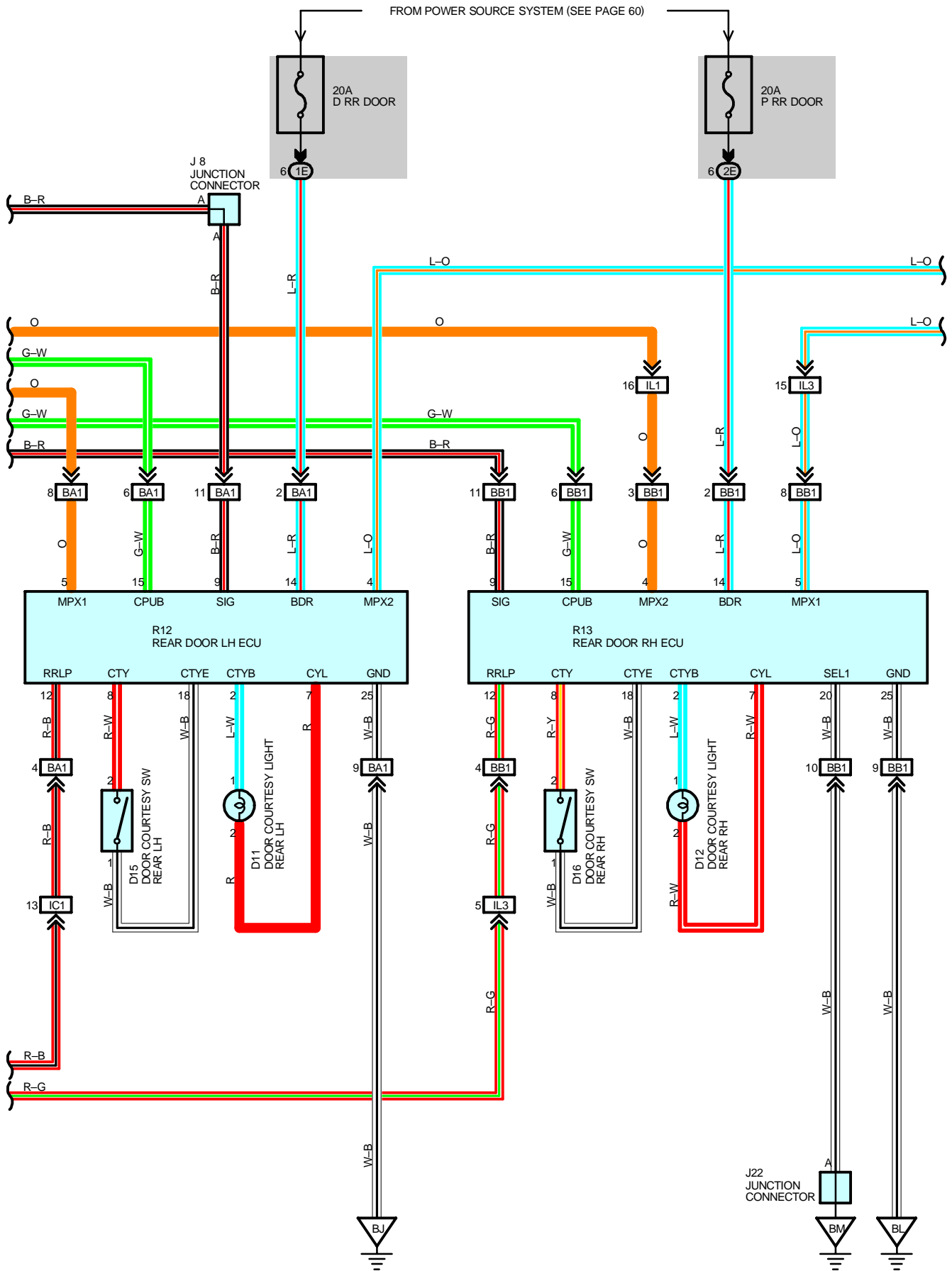

* 5 : W/ DRIVING POSITION MEMORY
* 6 : W/O DRIVING POSITION MEMORY

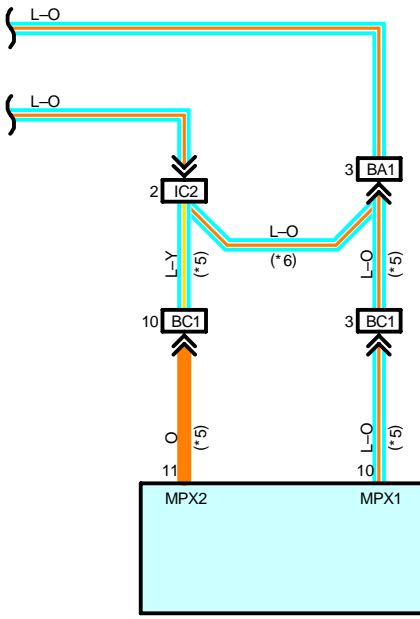

P19
POWER SEAT ECU

INTERIOR LIGHT

SYSTEM OUTLINE

ILLUMINATED ENTRY SYSTEM

This system provides various functions listed below through communication control of the body ECU and door ECU etc.

- * Each relevant light lights up if any door is opened.
- * If all the doors are closed with the ignition SW set at OFF after any door is opened, each light lights up for 15 sec., and then fades out when the time set on the timer has elapsed.
- * If any door is unlocked from the driver or passenger side or if any door is unlocked with the unlock SW on the transmitter after all the doors are closed and locked, each light lights up for 15 sec., and then fades out when the time set on the timer has elapsed.
- * If the ignition SW is turned to the ACC or ON position while each light is being lit by the timer, the timer lighting is cancelled and the light fades out.
- * If all the doors are closed and locked from the driver or passenger side or with the lock SW on the transmitter while each light is being lit, the timer lighting is cancelled and the light fades out.
- * If all the doors are closed with the ignition SW set at ACC or ON after any door is opened, the timer lighting is cancelled and the light fades out.
- * Each light above is the interior light, ignition key cylinder light, and step lights LH and RH.

SERVICE HINTS

D13, D14, D15, D16 DOOR COURTESY SW FRONT LH, RH, REAR LH, RH

1-2 : Closed with door open

L5 LUGGAGE COMPARTMENT DOOR COURTESY SW

2-GROUND : Luggage compartment door open

W5 WIRELESS DOOR LOCK ECU

7-GROUND : Always approx. 12 volts

1-GROUND : Always continuity

D23 (B) DRIVER DOOR ECU

15-14 : Continuity with driver door open

F12 (B) FRONT PASSENGER DOOR ECU

15-14 : Continuity with front passenger door open

R12 REAR DOOR LH ECU

8-18 : Continuity with rear LH door open

R13 REAR DOOR RH ECU

8-18 : Continuity with rear RH door open

○ : PARTS LOCATION

Code	See Page	Code	See Page	Code	See Page		
A13	40	E5	D	38 (2JZ-GE)	J22	42	
B5	A	40	E7	F	36 (1UZ-FE)	L5	43
B6	A	40	F11	A	42	L7	43
C13	40	F12	B	42	M3	41	
D8	42	F13	C	42	N6	43	
D9	42	I21		41	P7	43	
D10	42	I24		42	P19	44	
D11	42	I25		42	R12	43	
D12	42	J6		41	R13	43	
D13	42	J7		41	S5	41	
D14	42	J8		41	S6	41	
D15	42	J10		41	T5	41	
D16	42	J13		41	V8	43	
D22	A	42	J15	41	V9	43	
D23	B	42	J17	41	W5	43	
D24	C	42	J20	42			

 : RELAY BLOCKS

Code	See Page	Relay Blocks (Relay Block Location)
1	22	Engine Room No.1 R/B (Engine Compartment Right)

 : JUNCTION BLOCK AND WIRE HARNESS CONNECTOR

Code	See Page	Junction Block and Wire Harness (Connector Location)
1E	26	Floor No.2 Wire and Driver Side J/B (Left Kick Panel)
1F	26	Cowl Wire and Driver Side J/B (Left Kick Panel)
1G	27	
1H		
2B	28	
2D	28	Roof Wire and Passenger Side J/B (Right Kick Panel)
2E	28	Floor No.1 Wire and Passenger Side J/B (Right Kick Panel)
2F	28	Cowl Wire and Passenger Side J/B (Right Kick Panel)
2G	29	
2H		

 : CONNECTOR JOINING WIRE HARNESS AND WIRE HARNESS

Code	See Page	Joining Wire Harness and Wire Harness (Connector Location)
IB1	50	Front Door LH Wire and Cowl Wire (Left Kick Panel)
IC1	50	Floor No.2 Wire and Cowl Wire (Left Kick Panel)
IC2		
IC3		
IE1	50	Instrument Panel Wire and Cowl Wire (Left Side of the Steering Column)
IJ1	52	Instrument Panel Wire and Cowl Wire (Left Side of the Blower Unit)
IJ2		
IK1	52	Front Door RH Wire and Cowl Wire (Right Kick Panel)
IL1	52	Floor No.1 Wire and Cowl Wire (Right Kick Panel)
IL3		
BA1	54	Rear Door LH Wire and Floor No.2 Wire (Under the Center Pillar LH)
BB1	54	Rear Door RH Wire and Floor No.1 Wire (Under the Center Pillar RH)
BC1	56	Floor No.2 Wire and Front Seat LH Wire (Under the Driver's Seat)

 : GROUND POINTS

Code	See Page	Ground Points Location
IF	50	Left Kick Panel
II	50	Right Side of the Cowl Panel
BJ	54	Rear Floor Partition Panel LH
BK	54	Quarter Panel LH
BL	54	Rear Floor Partition Panel RH
BM	54	Quarter Panel RH

 : SPLICE POINTS

Code	See Page	Wire Harness with Splice Points	Code	See Page	Wire Harness with Splice Points
I1	52	Cowl Wire	B2	54	Roof Wire
I6					

INTERIOR LIGHT

A13

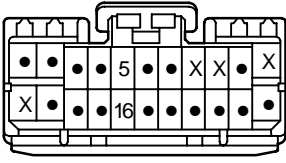

B5 (A)

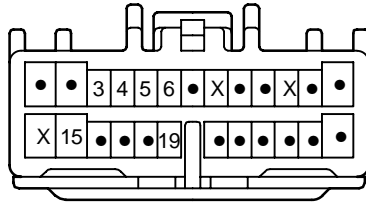

B6 (A)

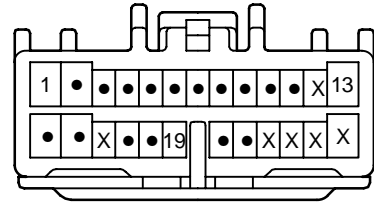

C13

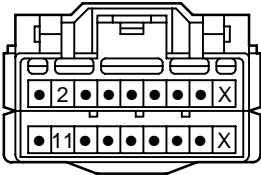

D8
GRAY

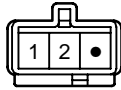

D9



D10

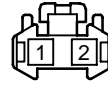

D11

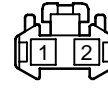

D12



D13
GRAY

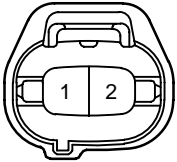

D14
GRAY

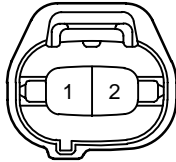

D15
GRAY

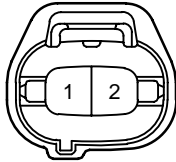

D16
GRAY

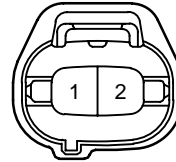

D22 (A)
GRAY

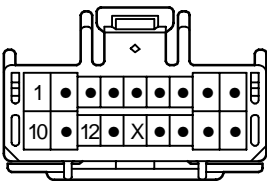

D23 (B)
GRAY

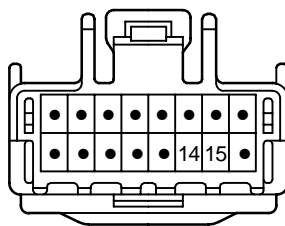

D24 (C)
GRAY

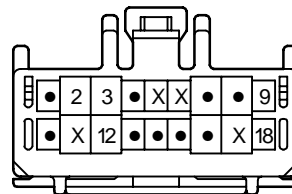

E5 (D)
(2JZ-GE)

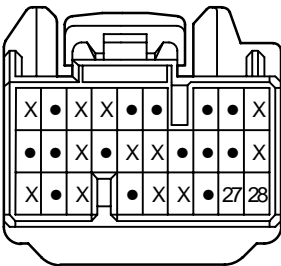

E7 (F)
(1UZ-FE)

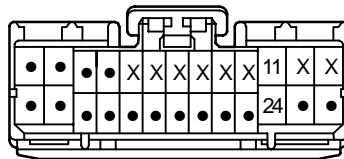

F11 (A)
GRAY

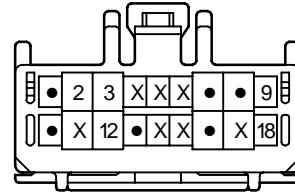

F12 (B)
GRAY

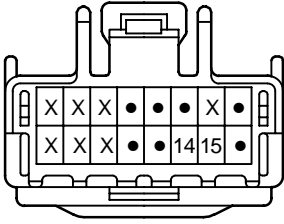

F13 (C)
GRAY

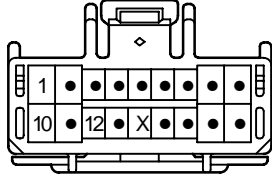

I21

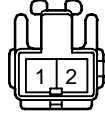

I24

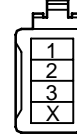

I25

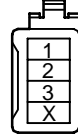

J6

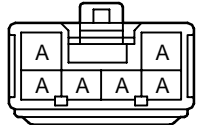

(Hint : See Page 7)

J7
GRAY

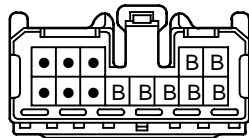

(Hint : See Page 7)

J8
BLACK



(Hint : See Page 7)

J10
ORANGE

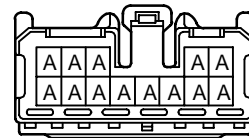

(Hint : See Page 7)

J13

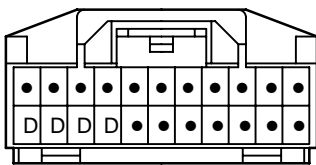

(Hint : See Page 7)

J15

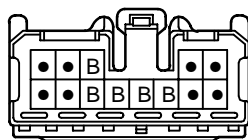

(Hint : See Page 7)

J17

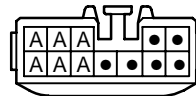

(Hint : See Page 7)

J20

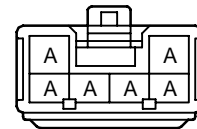

(Hint : See Page 7)

J22

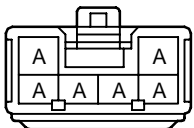

(Hint : See Page 7)

L5
BLACK

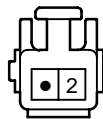

L7
GRAY



M3
BLUE

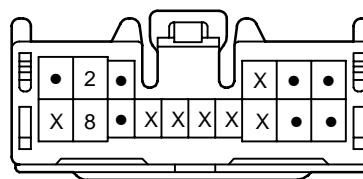

N6
BLUE

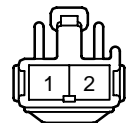

P7

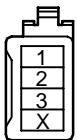

P19

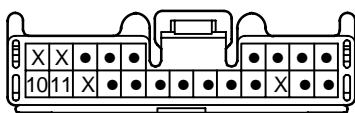

R12

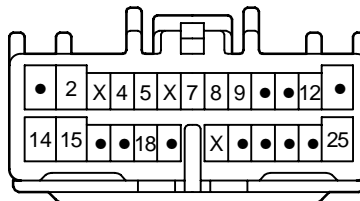

R13

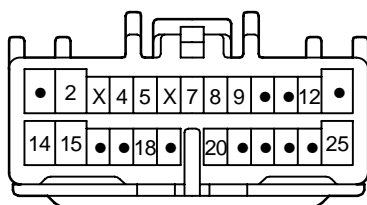

S5
BLACK



S6
BLACK



T5
GRAY

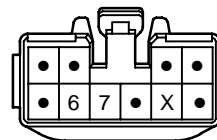

INTERIOR LIGHT

V8

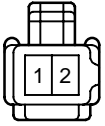

V9

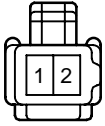

W5

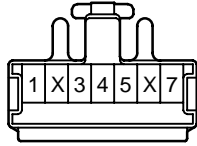

KEY REMINDER AND SEAT BELT WARNING

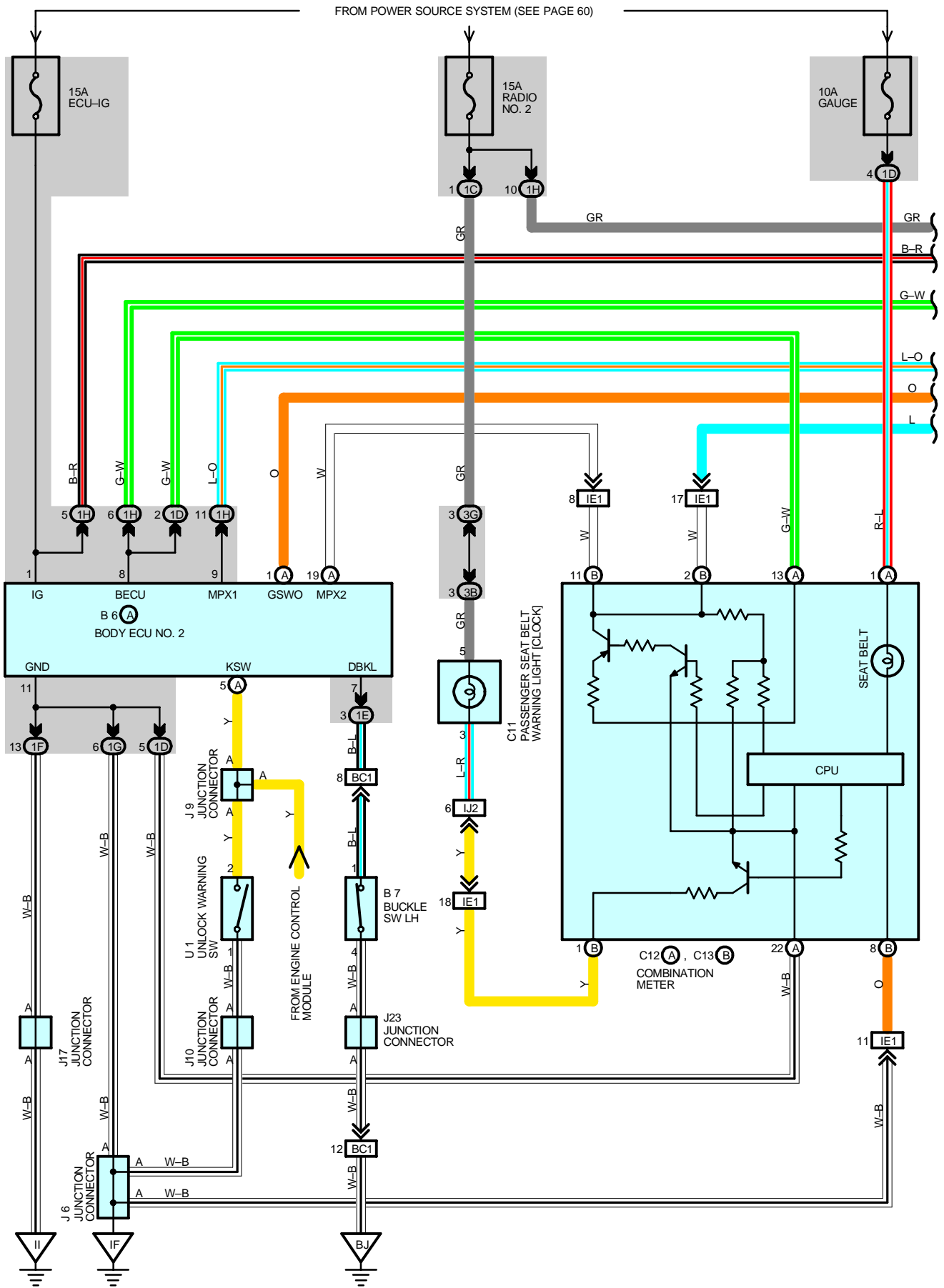

FROM POWER SOURCE SYSTEM (SEE PAGE 60)

- * 1 : W/ LEXUS NAVIGATION SYSTEM
- * 2 : W/O LEXUS NAVIGATION SYSTEM
- * 3 : 1UZ-FE
- * 4 : 2JZ-FE

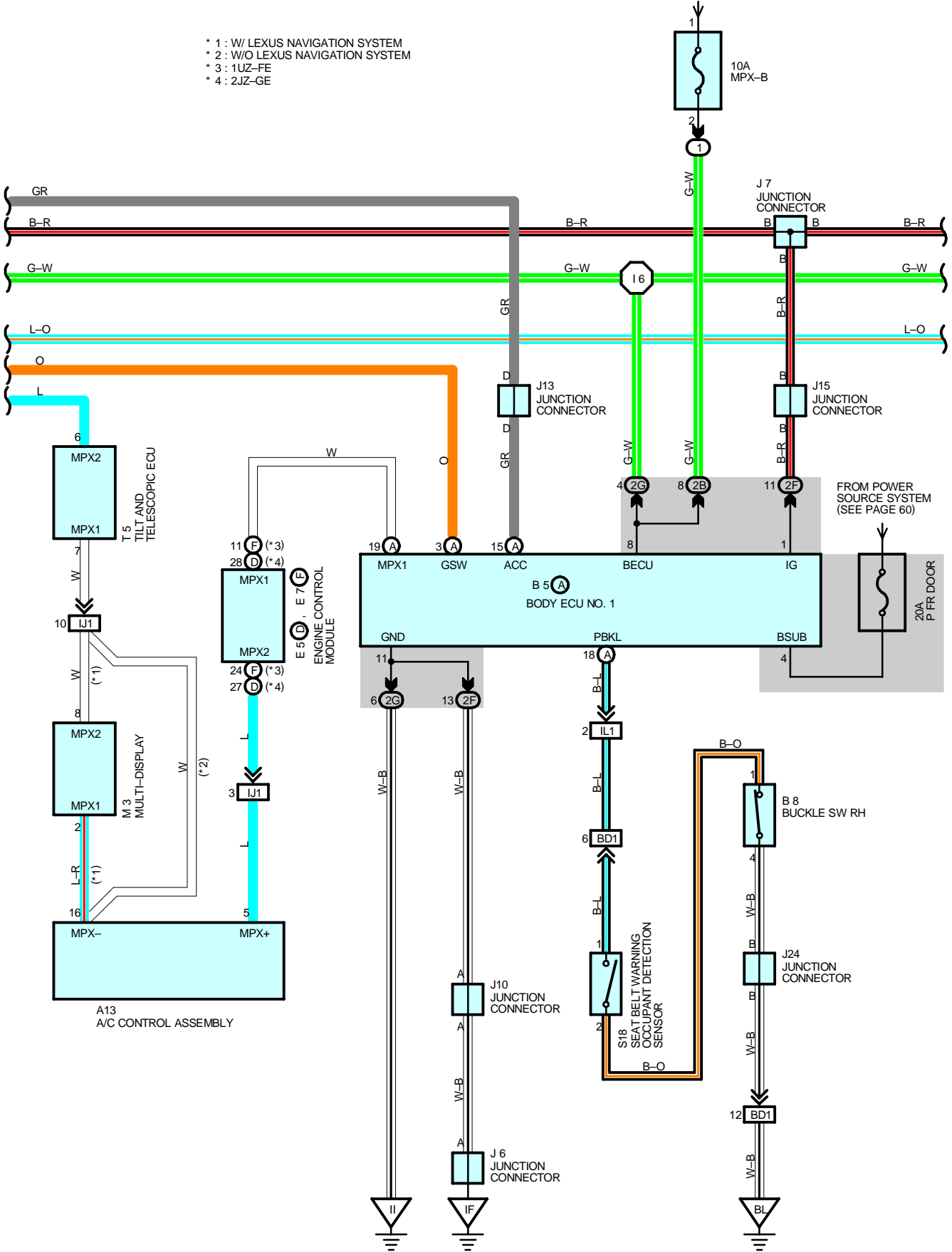

KEY REMINDER AND SEAT BELT WARNING

FROM POWER SOURCE SYSTEM (SEE PAGE 60)

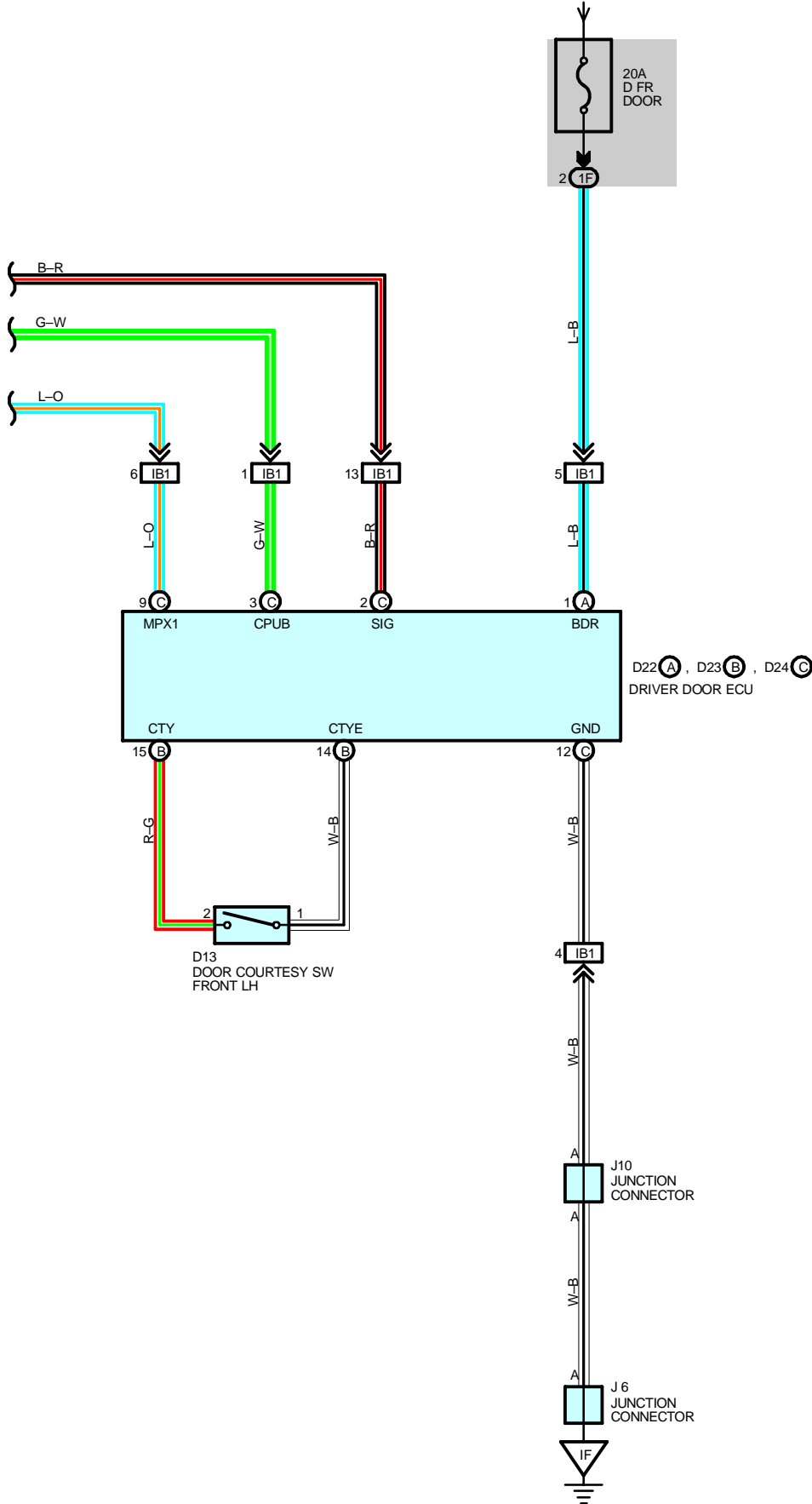

SYSTEM OUTLINE

1. SEAT BELT WARNING SYSTEM

When the ignition SW is turned to the ON position, the signal is input to the body ECU and door ECU. At this time, to determine whether or not the driver fastens the seat belt, the signal from the buckle SW LH is input to TERMINAL DBKL of the body ECU No.2. If the driver does not fasten the seat belt, the seat belt warning light in the combination meter flashes and the alarm buzzer goes on, in response to the communication control of the body ECU and door ECU etc.

Additionally, the sensor (Seat belt warning occupant detection sensor) installed on the front passenger seat detects the passenger and determines whether or not the passenger fastens the seat belt.

If the passenger does not fasten the seat belt, the signals from the seat sensor and buckle SW RH are input to TERMINAL PBKL of the body ECU No.1 and through communication control of the body ECU and door ECU etc. the passenger seat belt warning light in the clock is flashed.

2. KEY REMINDER SYSTEM

If the driver door is opened with the ignition SW set at the ACC or OFF position and the ignition key remained inserted into the key cylinder (The unlock warning SW is on), the signal from the unlock warning SW is input to TERMINAL KSW of the body ECU No.2 and the signal from the door courtesy SW front LH is input to TERMINAL CTY of driver door ECU. As a result, through communication control of the body ECU and door ECU etc. the buzzer in the combination meter goes on to warn the driver that the ignition key is still inserted.

SERVICE HINTS

S18 SEAT BELT WARNING OCCUPANT DETECTION SENSOR

1-2 : Closed with passenger sit on the front passenger seat.

○ : PARTS LOCATION

Code	See Page	Code	See Page	Code	See Page		
A13	40	D22	A	42	J13	41	
B5	A	40	D23	B	42	J15	41
B6	A	40	D24	C	42	J17	41
B7	44	E5	D	38 (2JZ-GE)	J23	44	
B8	44	E7	F	36 (1UZ-FE)	J24	44	
C11	40	J6		41	M3	41	
C12	A	40	J7	41	S18	44	
C13	B	40	J9	41	T5	41	
D13	42	J10		41	U1	41	

○ : RELAY BLOCKS

Code	See Page	Relay Blocks (Relay Block Location)
1	22	Engine Room No.1 R/B (Engine Compartment Right)

○ : JUNCTION BLOCK AND WIRE HARNESS CONNECTOR

Code	See Page	Junction Block and Wire Harness (Connector Location)
1C	26	Instrument Panel Wire and Driver Side J/B (Left Kick Panel)
1D		
1E	26	Floor No.2 Wire and Driver Side J/B (Left Kick Panel)
1F	26	Cowl Wire and Driver Side J/B (Left Kick Panel)
1G	27	
1H		
2B	28	Engine Room Main Wire and Passenger Side J/B (Right Kick Panel)
2F	28	Cowl Wire and Passenger Side J/B (Right Kick Panel)
2G	29	
3B	30	Instrument Panel Wire and Instrument Panel J/B (Instrument Panel Reinforcement Center)
3G	31	

KEY REMINDER AND SEAT BELT WARNING

□ : CONNECTOR JOINING WIRE HARNESS AND WIRE HARNESS

Code	See Page	Joining Wire Harness and Wire Harness (Connector Location)
IB1	50	Front Door LH Wire and Cowl Wire (Left Kick Panel)
IE1	50	Instrument Panel Wire and Cowl Wire (Left Side of the Steering Column)
IJ1	52	Instrument Panel Wire and Cowl Wire (Left Side of the Blower Unit)
IJ2		
IL1	52	Floor No.1 Wire and Cowl Wire (Right Kick Panel)
BC1	56	Floor No.2 Wire and Front Seat LH Wire (Under the Driver's Seat)
BD1	56	Floor No.1 Wire and Front Seat RH Wire (Under the Front Passenger's Seat)

▽ : GROUND POINTS

Code	See Page	Ground Points Location
IF	50	Left Kick Panel
II	50	Right Side of the Cowl Panel
BJ	54	Rear Floor Partition Panel LH
BL	54	Rear Floor Partition Panel RH

○ : SPLICE POINTS

Code	See Page	Wire Harness with Splice Points	Code	See Page	Wire Harness with Splice Points
I6	52	Cowl Wire			

A13

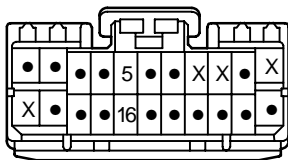

B5 (A)

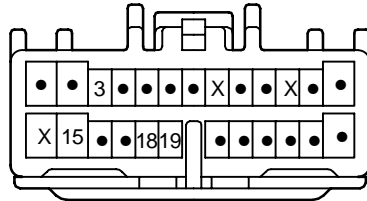

B6 (A)

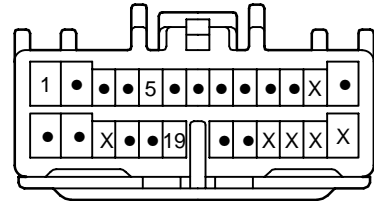

B7

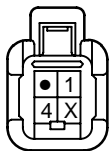

B8

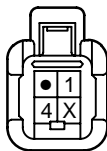

C11

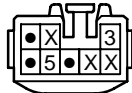

C12 (A)

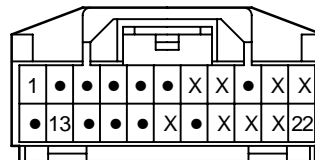

C13 (B)

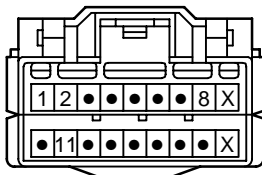

**D13
GRAY**

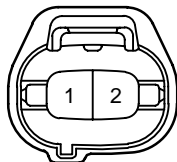

**D22 (A)
GRAY**

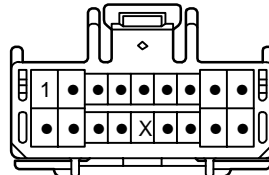

**D23 (B)
GRAY**

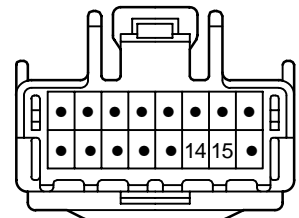

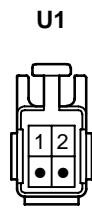
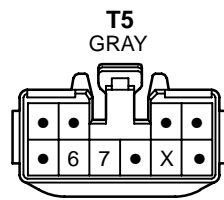
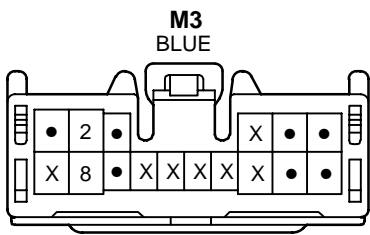
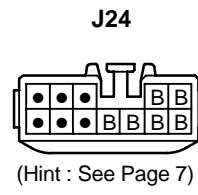
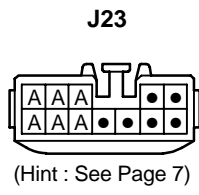
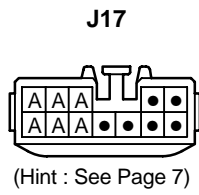
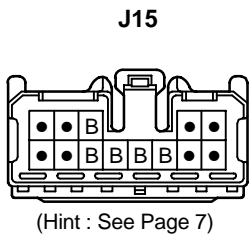
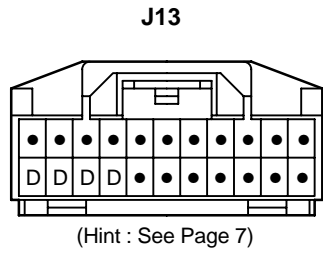
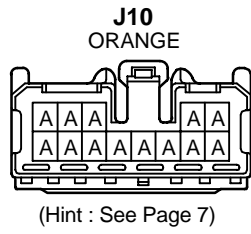
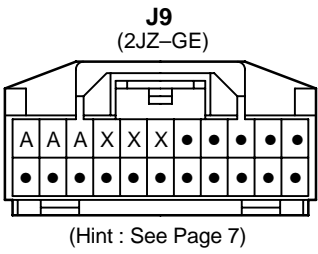
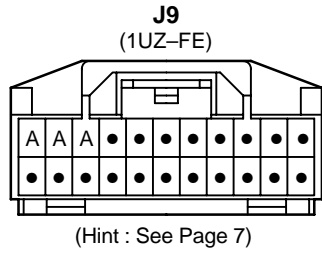
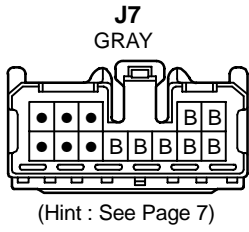
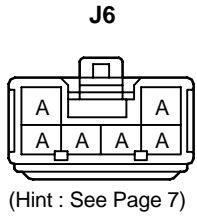
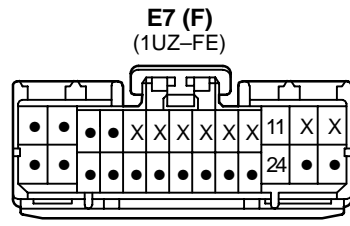
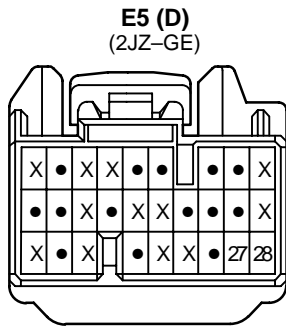
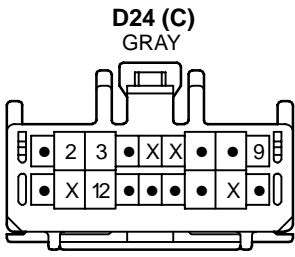

LEXUS NAVIGATION SYSTEM

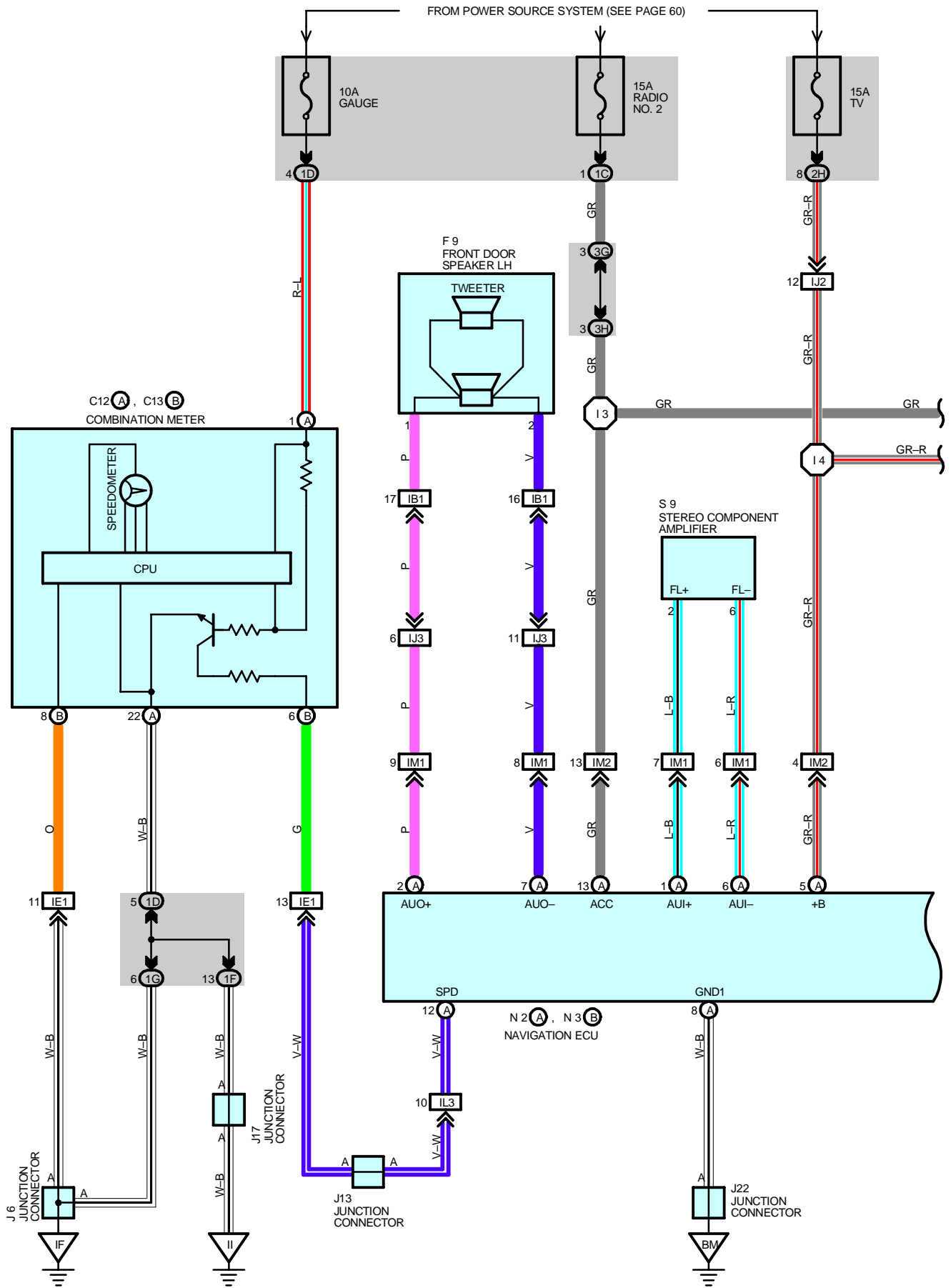

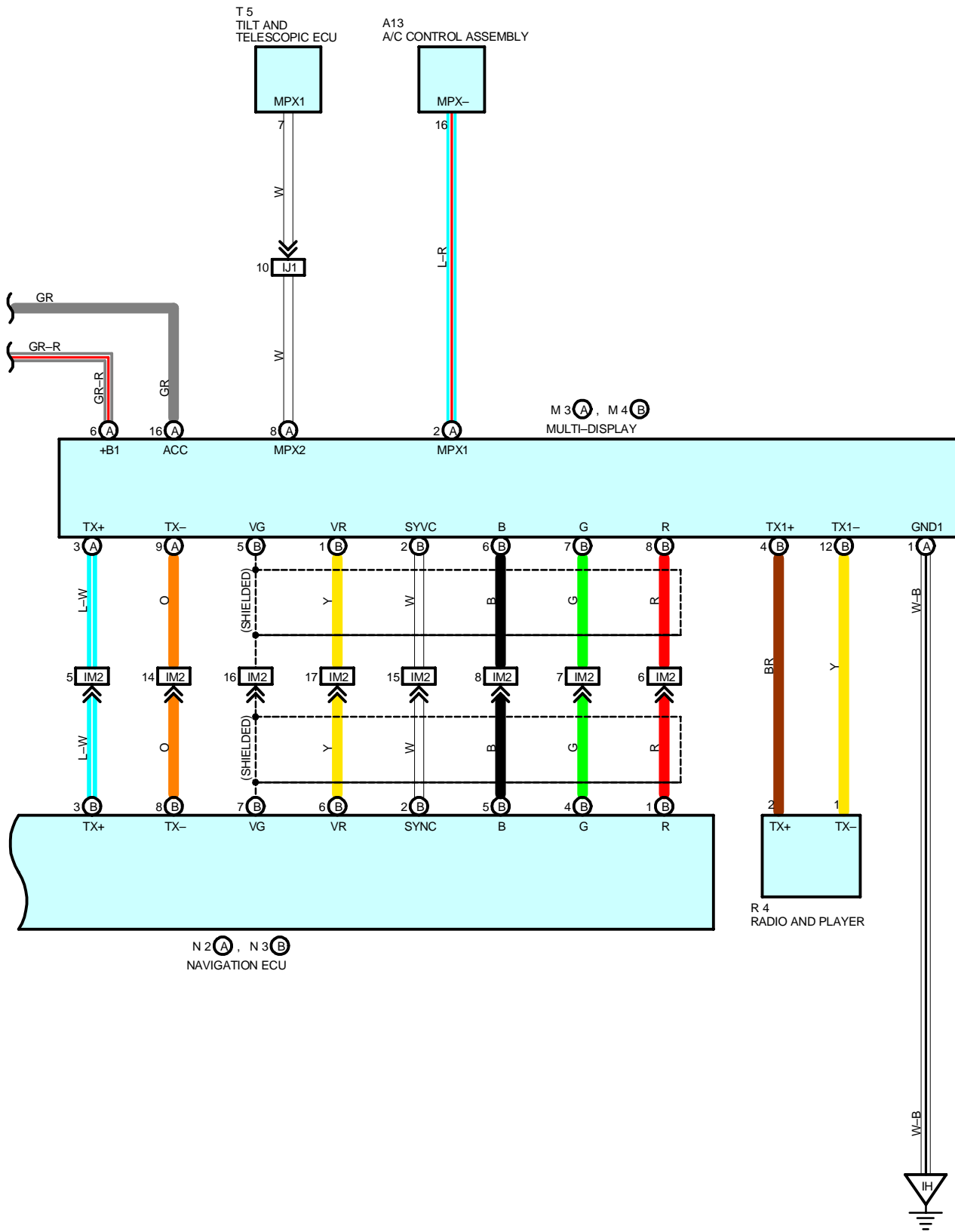

LEXUS NAVIGATION SYSTEM

SYSTEM OUTLINE

The LEXUS navigation system displays the operating status and instructions for the automatic air conditioning or radio and player, as well as trip information. Additionally, the navigation system precisely measures the current vehicle position, displays the map obtained from the map database on the screen, and informs the route to the destination shown on the map using voice guidance.

SERVICE HINTS

N2 (A) NAVIGATION ECU

- 5-GROUND : Always approx. 12 volts
- 13-GROUND : Approx. 12 volts with ignition SW at **ACC** or **ON** position
- 8-GROUND : Always continuity

M3 (A) MULTI-DISPLAY

- 6-GROUND : Always approx. 12 volts
- 16-GROUND : Approx. 12 volts with ignition SW at **ACC** or **ON** position
- 1-GROUND : Always continuity

○ : PARTS LOCATION

Code	See Page	Code	See Page	Code	See Page
A13	40	J13	41	N2 A	43
C12 A	40	J17	41	N3 B	43
C13 B	40	J22	42	R4	41
F9	42	M3 A	41	S9	41
J6	41	M4 B	41	T5	41

○ : JUNCTION BLOCK AND WIRE HARNESS CONNECTOR

Code	See Page	Junction Block and Wire Harness (Connector Location)
1C	26	Instrument Panel Wire and Driver Side J/B (Left Kick Panel)
1D		
1F	26	Cowl Wire and Driver Side J/B (Left Kick Panel)
1G	27	
2H	29	Cowl Wire and Passenger Side J/B (Right Kick Panel)
3G	31	Instrument Panel Wire and Instrument Panel J/B (Instrument Panel Reinforcement Center)
3H		

□ : CONNECTOR JOINING WIRE HARNESS AND WIRE HARNESS

Code	See Page	Joining Wire Harness and Wire Harness (Connector Location)
IB1	50	Front Door LH Wire and Cowl Wire (Left Kick Panel)
IE1	50	Instrument Panel Wire and Cowl Wire (Left Side of the Steering Column)
IJ1	52	Instrument Panel Wire and Cowl Wire (Left Side of the Blower Unit)
IJ2		
IJ3		
IL3	52	Floor No.1 Wire and Cowl Wire (Right Kick Panel)
IM1	52	Instrument Panel Wire and Floor No.1 Wire (Front RH Side of the Shift Lever)
IM2		

▽ : GROUND POINTS

Code	See Page	Ground Points Location
IF	50	Left Kick Panel
IH	50	Instrument Panel Brace RH
II	50	Right Side of the Cowl Panel
BM	54	Quarter Panel RH



: SPLICE POINTS

Code	See Page	Wire Harness with Splice Points	Code	See Page	Wire Harness with Splice Points
I3	52	Instrument Panel Wire	I4	52	Instrument Panel Wire

A13

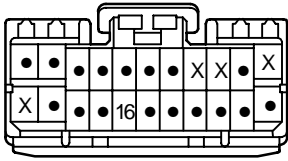

C12 (A)

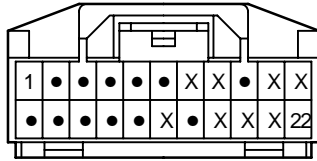

C13 (B)

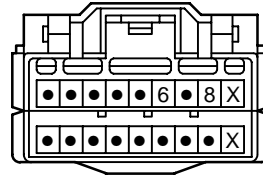

F9



J6

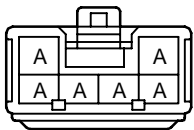

(Hint : See Page 7)

J13

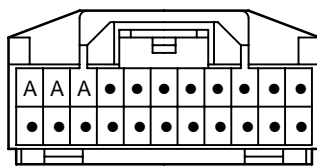

(Hint : See Page 7)

J17

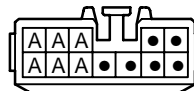

(Hint : See Page 7)

J22

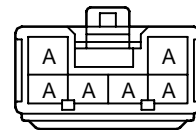

(Hint : See Page 7)

M3 (A)
BLUE

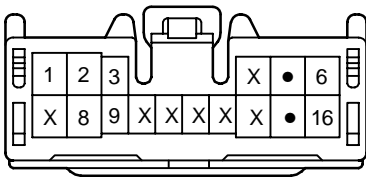

M4 (B)

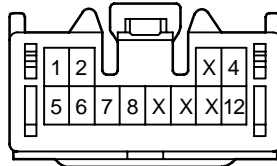

N2 (A)

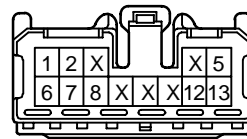

N3 (B)

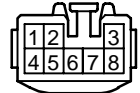

R4

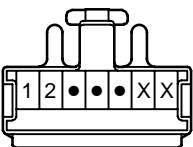

S9

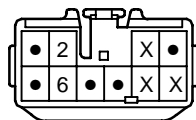

T5
GRAY

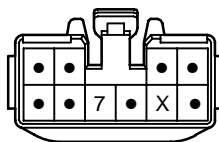

LIGHT AUTO TURN OFF

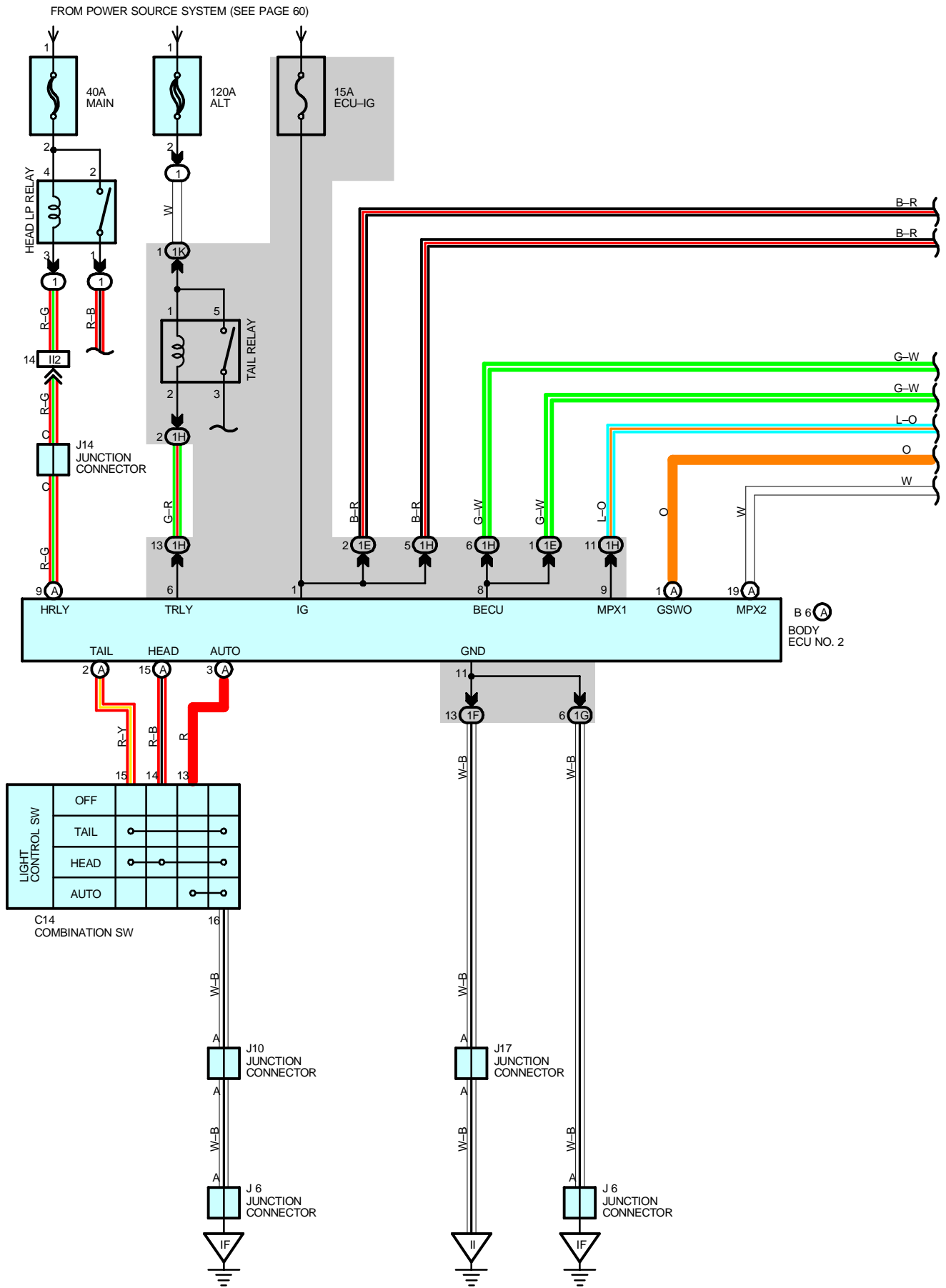

* 1 : W/ LEXUS NAVIGATION SYSTEM
 * 2 : W/O LEXUS NAVIGATION SYSTEM

* 3 : 1UZ-FE
 * 4 : 2JZ-GE

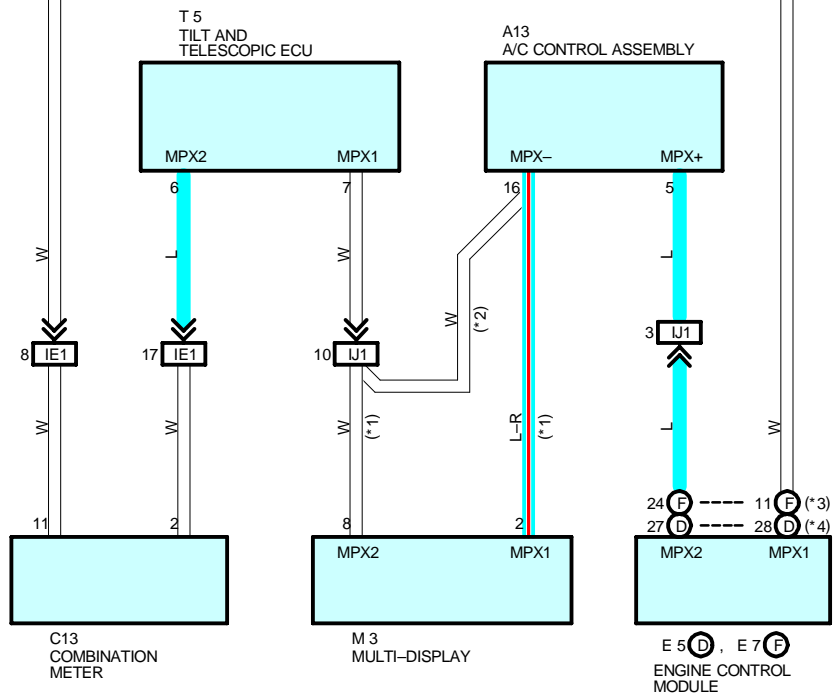
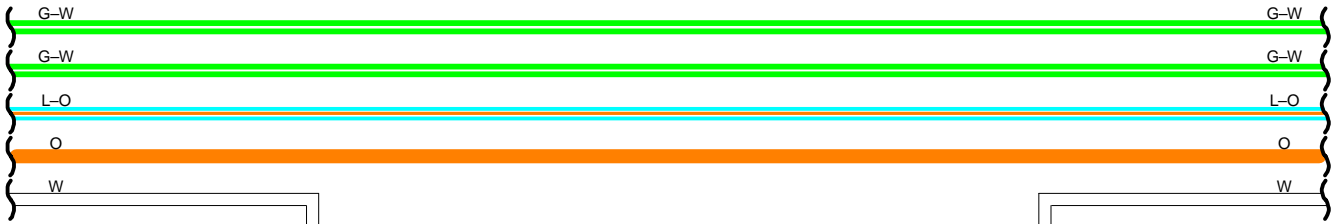
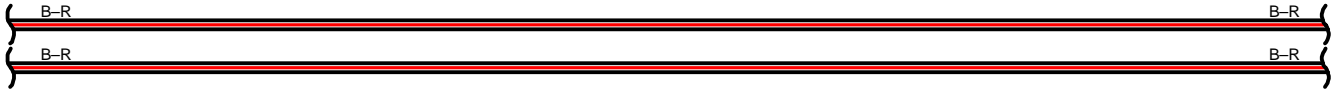

LIGHT AUTO TURN OFF

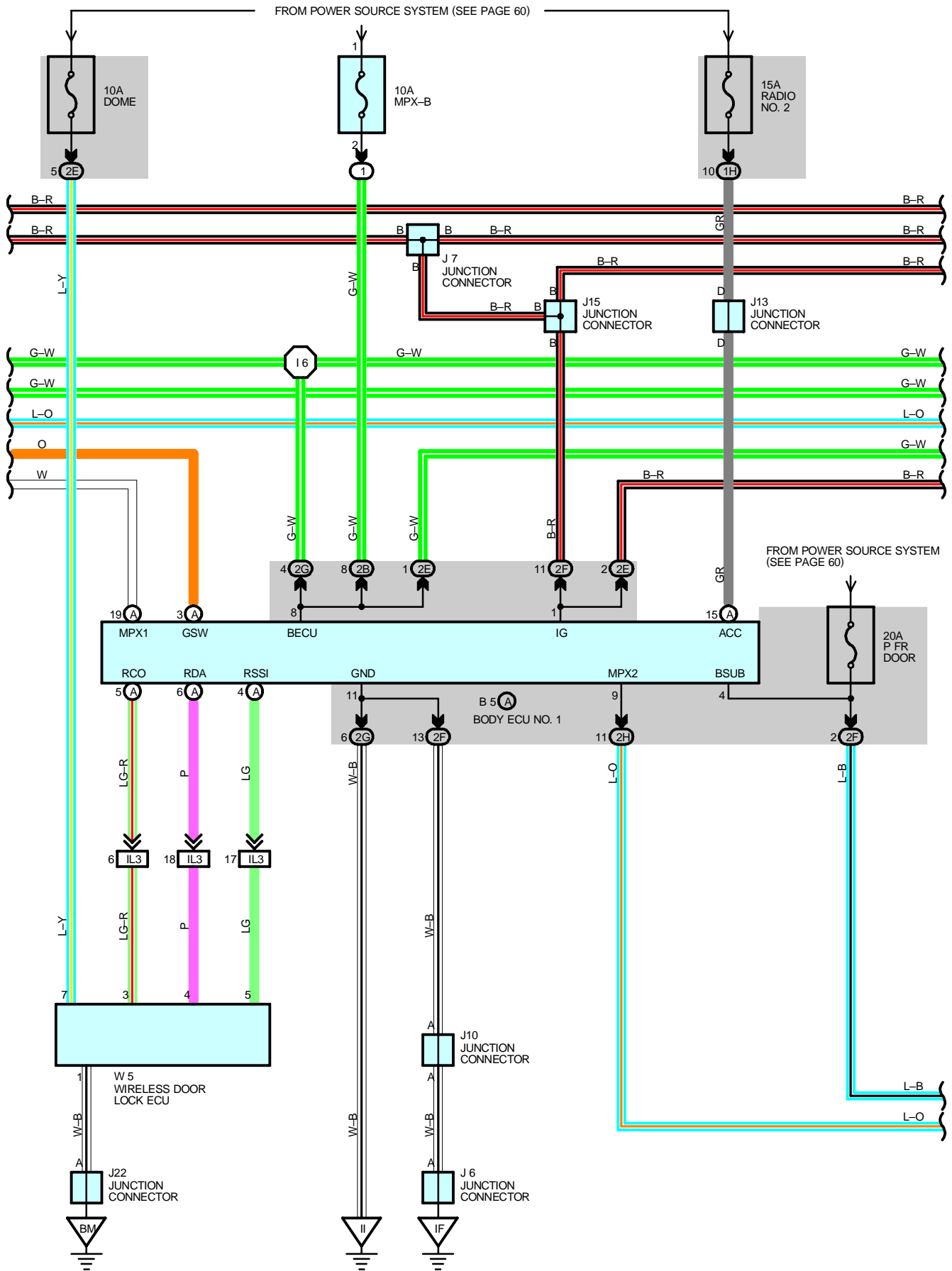

FROM POWER SOURCE SYSTEM (SEE PAGE 60)

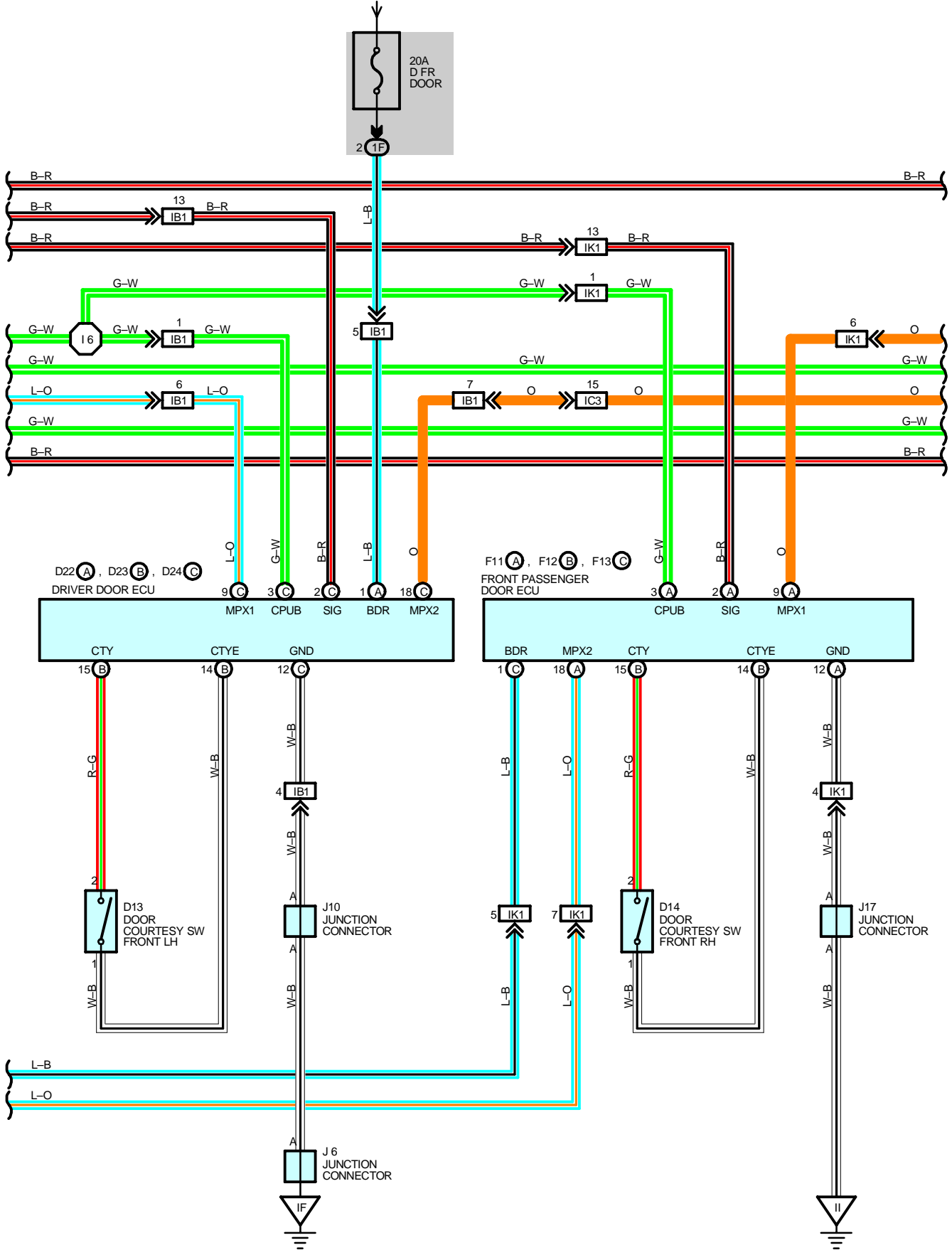

LIGHT AUTO TURN OFF

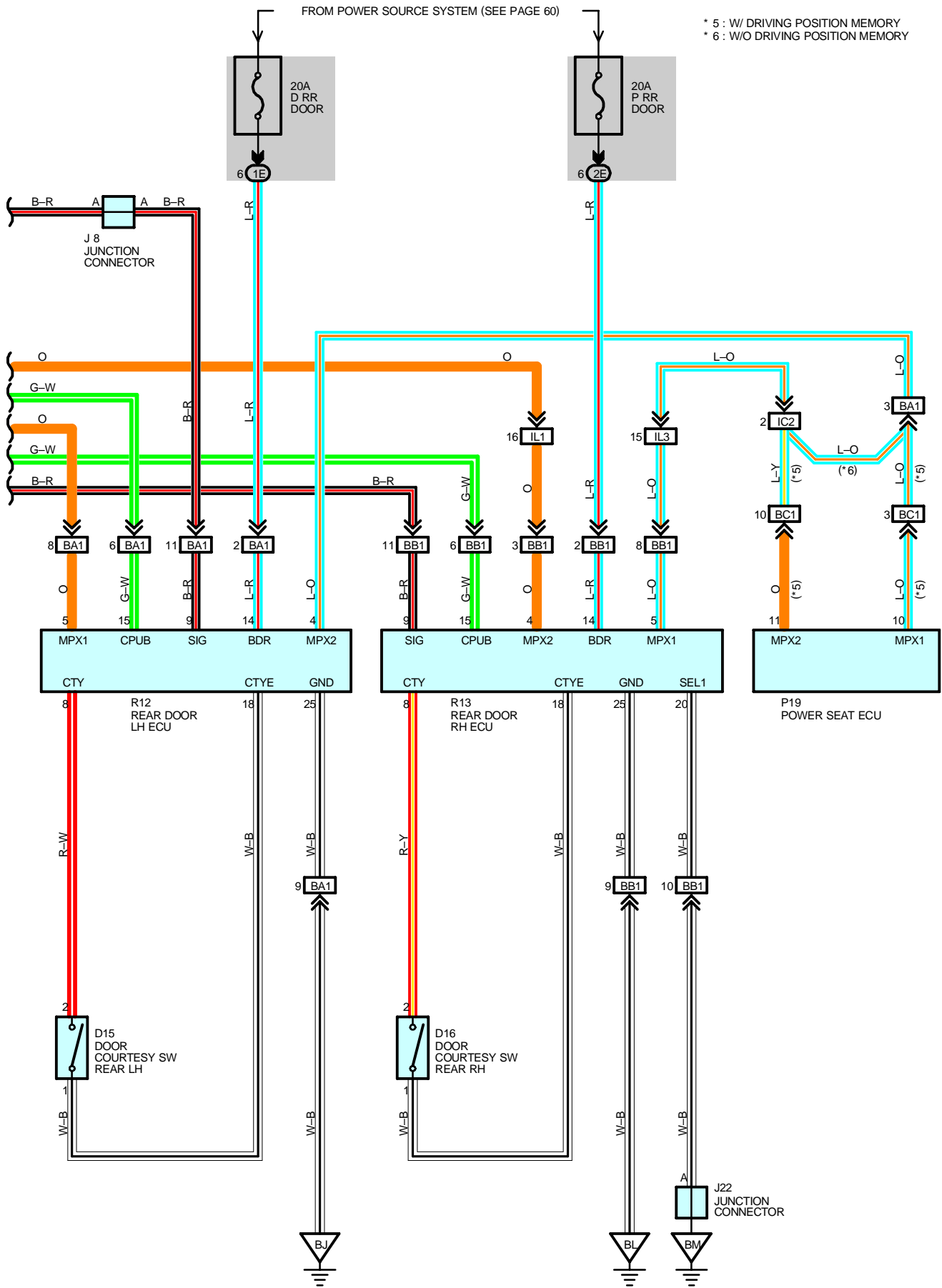

SYSTEM OUTLINE

This system automatically turns off the taillights and/or headlights when the driver door is opened and closed to prevent the lights from remaining lit.

LIGHT AUTO TURN OFF OPERATION

* Taillights ON

If the ignition SW is turned from ON to OFF with the taillights turned on (The light control SW is set at TAIL), the signal is input to TERMINAL IG of the body ECU No.2. At this time, if the driver door is opened, the signal is input from the door courtesy SW front LH to TERMINAL CTY of the driver door ECU. After that, TERMINAL TRLY of the body ECU No.2 is controlled through communication control of the body ECU and door ECU etc. to turn off the TAIL relay. As a result, the current flowing into the taillights is cut off to turn off the taillights.

* Taillights and headlights ON

If the ignition SW is turned from ON to OFF with the taillights and headlights turned on (The light control SW is set at HEAD), the signal is input to TERMINAL IG of the body ECU No.2. At this time, if any door is opened, the signal is input from the door courtesy SW to TERMINAL CTY of the driver door ECU. During this operation, the taillights and headlights are remained lit. When all doors and the luggage door are closed, the taillights and headlights are turned on for 30 sec. through communication control of the body ECU and door ECU. After the set time has elapsed, a signal is input to TERMINAL TRLY and HRLY of the body ECU No.2, to turn off the TAIL relay and HEAD LP relay. As a result, the current flowing into the taillights and headlights is cut off to turn off the taillights and headlights.

If any door is opened during above operation, the taillights and headlights light up for 30 sec. again, and then go off after all the doors have been closed.

Additionally, if the vehicle is locked using the wireless door lock operation while the taillights and headlights are being turned on for 30 sec., the taillights and headlights go off immediately.

SERVICE HINTS

C14 COMBINATION SW

- 15-16 : Closed with light control SW at **TAIL** or **HEAD** position
- 14-16 : Closed with light control SW at **HEAD** position
- 13-16 : Closed with light control SW at **AUTO** position

W5 WIRELESS DOOR LOCK ECU

- 7-GROUND : Always approx. **12** volts
- 1-GROUND : Always continuity

D13, D14, D15, D16 DOOR COURTESY SW FRONT LH, RH, REAR LH, RH

- 1-2 : Closed with door open

D23 (B) DRIVER DOOR ECU

- 15-14 : Continuity with driver door open

F12 (B) FRONT PASSENGER DOOR ECU

- 15-14 : Continuity with front passenger door open

R12 REAR DOOR LH ECU

- 8-18 : Continuity with rear LH door open

R13 REAR DOOR RH ECU

- 8-18 : Continuity with rear RH door open

LIGHT AUTO TURN OFF

○ : PARTS LOCATION

Code	See Page	Code	See Page	Code	See Page		
A13	40	D24	C	42	J14	41	
B5	A	40	E5	D	38 (2JZ-GE)	J15	41
B6	A	40	E7	F	36 (1UZ-FE)	J17	42
C13	40	F11	A	42	J22	42	
C14	40	F12	B	42	M3	41	
D13	42	F13	C	42	P19	44	
D14	42	J6	41	R12	43		
D15	42	J7	41	R13	43		
D16	42	J8	41	T5	41		
D22	A	42	J10	41	W5	43	
D23	B	42	J13	41			

○ : RELAY BLOCKS

Code	See Page	Relay Blocks (Relay Block Location)
1	22	Engine Room No.1 R/B (Engine Compartment Right)

○ : JUNCTION BLOCK AND WIRE HARNESS CONNECTOR

Code	See Page	Junction Block and Wire Harness (Connector Location)
1E	26	Floor No.2 Wire and Driver Side J/B (Left Kick Panel)
1F	26	Cowl Wire and Driver Side J/B (Left Kick Panel)
1G	27	
1H		
1K	26	Engine Room Main Wire and Driver Side J/B (Left Kick Panel)
2B	28	Engine Room Main Wire and Passenger Side J/B (Right Kick Panel)
2E	28	Floor No.1 Wire and Passenger Side J/B (Right Kick Panel)
2F	28	Cowl Wire and Passenger Side J/B (Right Kick Panel)
2G	29	
2H		

□ : CONNECTOR JOINING WIRE HARNESS AND WIRE HARNESS

Code	See Page	Joining Wire Harness and Wire Harness (Connector Location)
IB1	50	Front Door LH Wire and Cowl Wire (Left Kick Panel)
IC2	50	Floor No.2 Wire and Cowl Wire (Left Kick Panel)
IC3		
IE1	50	Instrument Panel Wire and Cowl Wire (Left Side of the Steering Column)
II2	52	Engine Room Main Wire and Cowl Wire (Near the Passenger Side R/B)
IJ1	52	Instrument Panel Wire and Cowl Wire (Left Side of the Blower Unit)
IK1	52	Front Door RH Wire and Cowl Wire (Right Kick Panel)
IL1	52	Floor No.1 Wire and Cowl Wire (Right Kick Panel)
IL3		
BA1	54	Rear Door LH Wire and Floor No.2 Wire (Under the Center Pillar LH)
BB1	54	Rear Door RH Wire and Floor No.1 Wire (Under the Center Pillar RH)
BC1	56	Floor No.2 Wire and Front Seat LH Wire (Under the Driver's Seat)

▽ : GROUND POINTS

Code	See Page	Ground Points Location
IF	50	Left Kick Panel
II	50	Right Side of the Cowl Panel
BJ	54	Rear Floor Partition Panel LH
BL	54	Rear Floor Partition Panel RH
BM	54	Quarter Panel RH

○ : SPLICE POINTS

Code	See Page	Wire Harness with Splice Points	Code	See Page	Wire Harness with Splice Points
I6	52	Cowl Wire			

A13

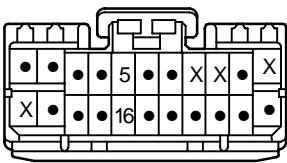

B5 (A)

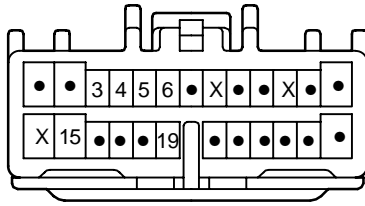

B6 (A)

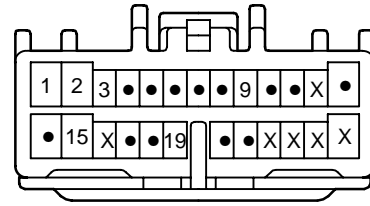

C13

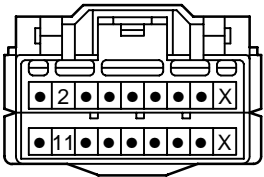

C14

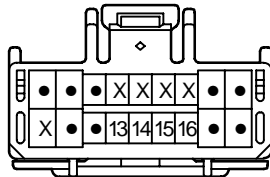

**D13
GRAY**

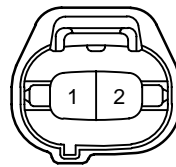

**D14
GRAY**

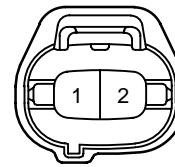

**D15
GRAY**

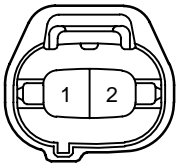

**D16
GRAY**

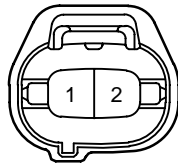

**D22 (A)
GRAY**

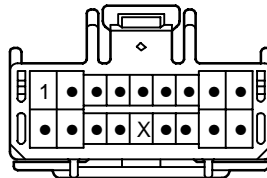

**D23 (B)
GRAY**

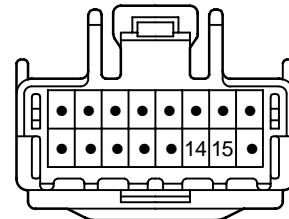

**D24 (C)
GRAY**

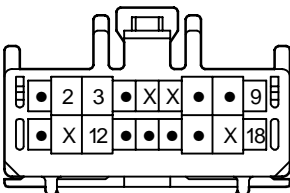

**E5 (D)
(2JZ-GE)**

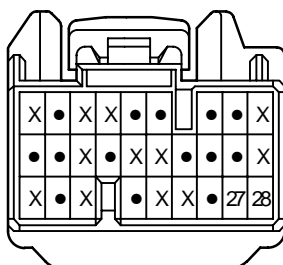

**E7 (F)
(1UZ-FE)**

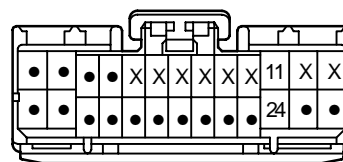

LIGHT AUTO TURN OFF

F11 (A)
GRAY

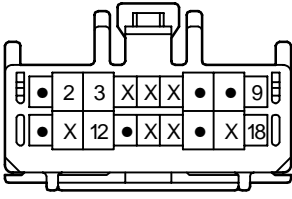

F12 (B)
GRAY

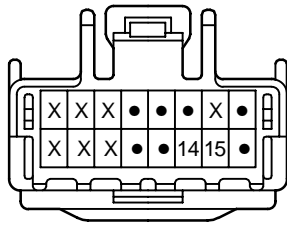

F13 (C)
GRAY

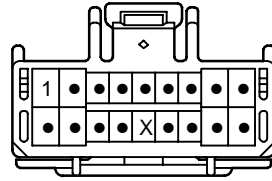

J6

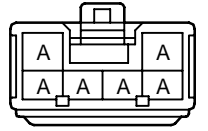

(Hint : See Page 7)

J7
GRAY

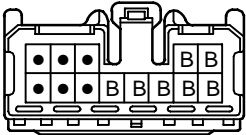

(Hint : See Page 7)

J8
BLACK



(Hint : See Page 7)

J10
ORANGE

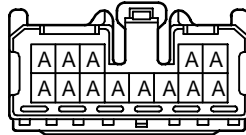

(Hint : See Page 7)

J13

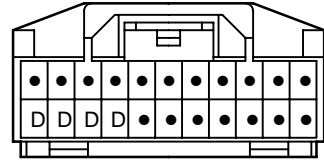

(Hint : See Page 7)

J14

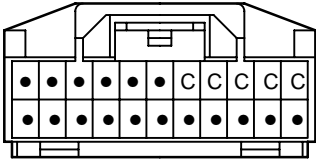

(Hint : See Page 7)

J15

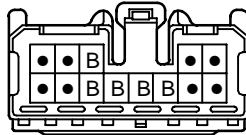

(Hint : See Page 7)

J17



(Hint : See Page 7)

J22

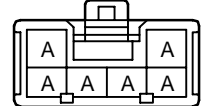

(Hint : See Page 7)

M3
BLUE

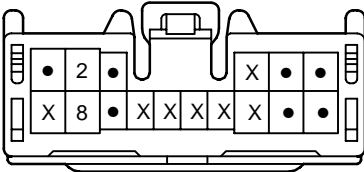

P19

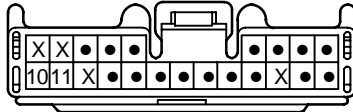

R12

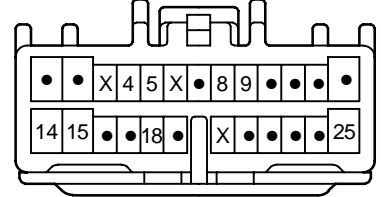

R13

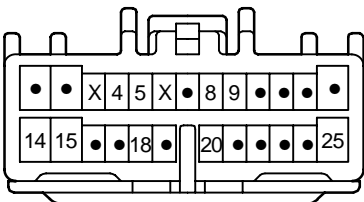

T5
GRAY

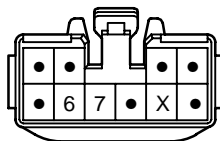

W5

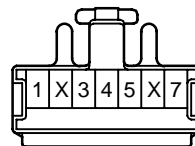

LUGGAGE COMPARTMENT DOOR OPENER

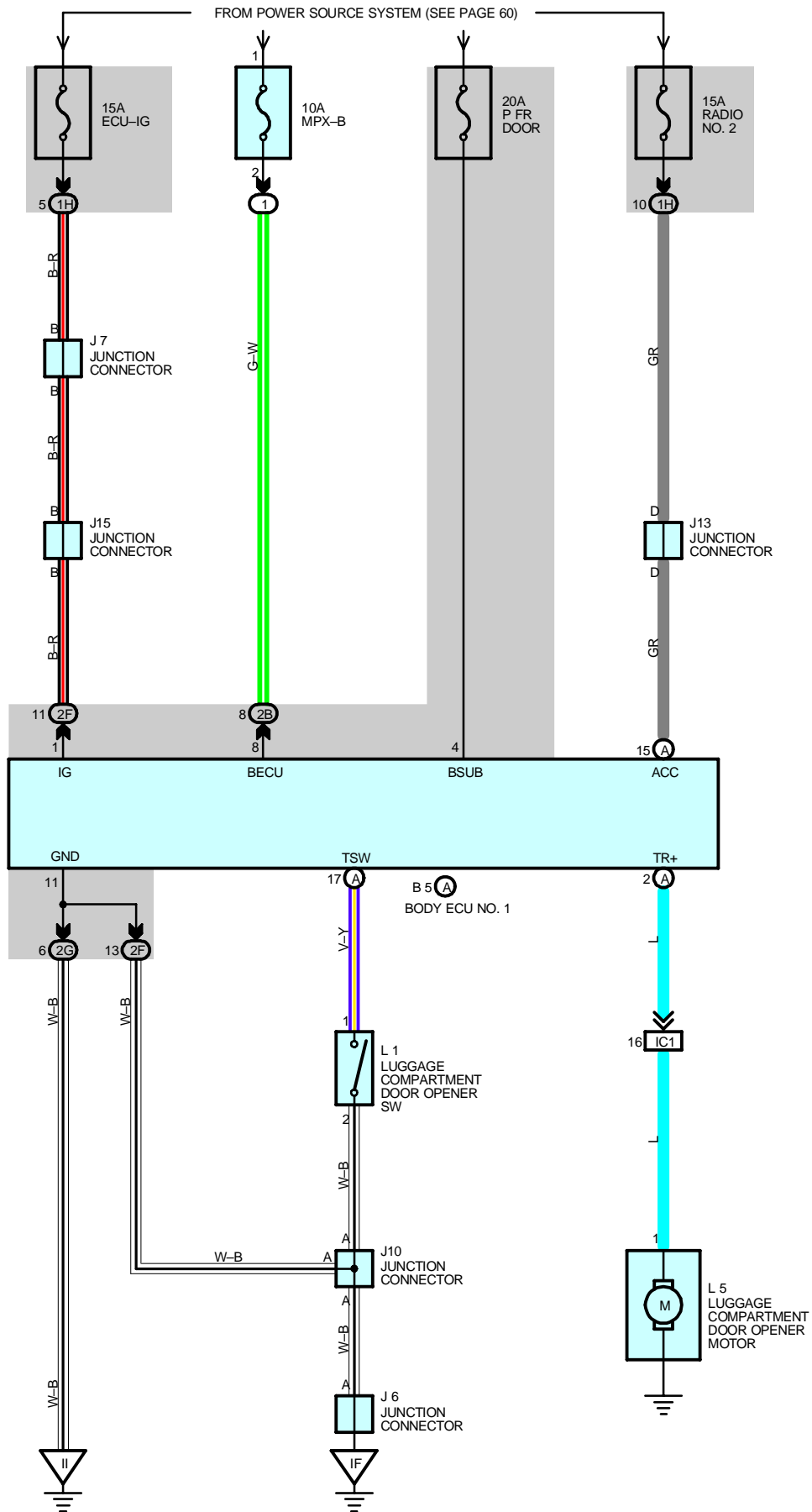

SERVICE HINTS

L1 LUGGAGE COMPARTMENT DOOR OPENER SW

1-2 : Closed with the luggage compartment door open

B5 (A) BODY ECU NO.1

1-GROUND : Approx. **12** volts with ignition SW at **ON** or **ST** position

4, 8-GROUND : Always approx. **12** volts

(A)15-GROUND : Approx. **12** volts with ignition SW at **ACC** or **ON** position

(A)17-GROUND : Continuity with luggage compartment door open

○ : PARTS LOCATION

Code	See Page	Code	See Page	Code	See Page
B5	A	40		J10	41
J6	41	J13	41	L1	41
J7	41	J15	41	L5	43

○ : RELAY BLOCKS

Code	See Page	Relay Blocks (Relay Block Location)
1	22	Engine Room No.1 R/B (Engine Compartment Right)

○ : JUNCTION BLOCK AND WIRE HARNESS CONNECTOR

Code	See Page	Junction Block and Wire Harness (Connector Location)
1H	27	Cowl Wire and Driver Side J/B (Left Kick Panel)
2B	28	Engine Room Main Wire and Passenger Side J/B (Right Kick Panel)
2F	28	Cowl Wire and Passenger Side J/B (Right Kick Panel)
2G	29	

□ : CONNECTOR JOINING WIRE HARNESS AND WIRE HARNESS

Code	See Page	Joining Wire Harness and Wire Harness (Connector Location)
IC1	50	Floor No.2 Wire and Cowl Wire (Left Kick Panel)

▽ : GROUND POINTS

Code	See Page	Ground Points Location
IF	50	Left Kick Panel
II	50	Right Side of the Cowl Panel

B5 (A)

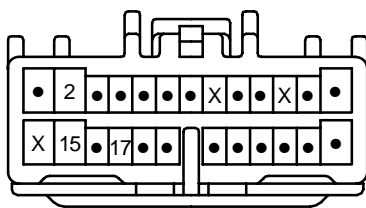

J6

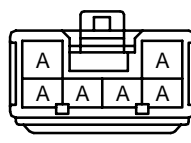

(Hint : See Page 7)

J7
GRAY

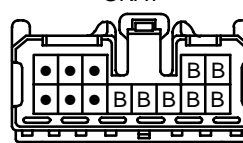

(Hint : See Page 7)

J10
ORANGE

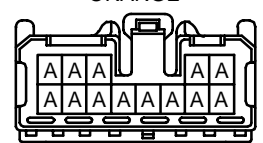

(Hint : See Page 7)

J13

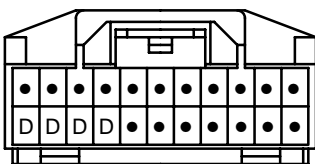

(Hint : See Page 7)

J15

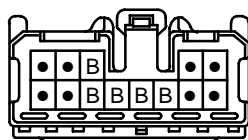

(Hint : See Page 7)

L1



L5
BLACK

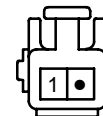

MOON ROOF

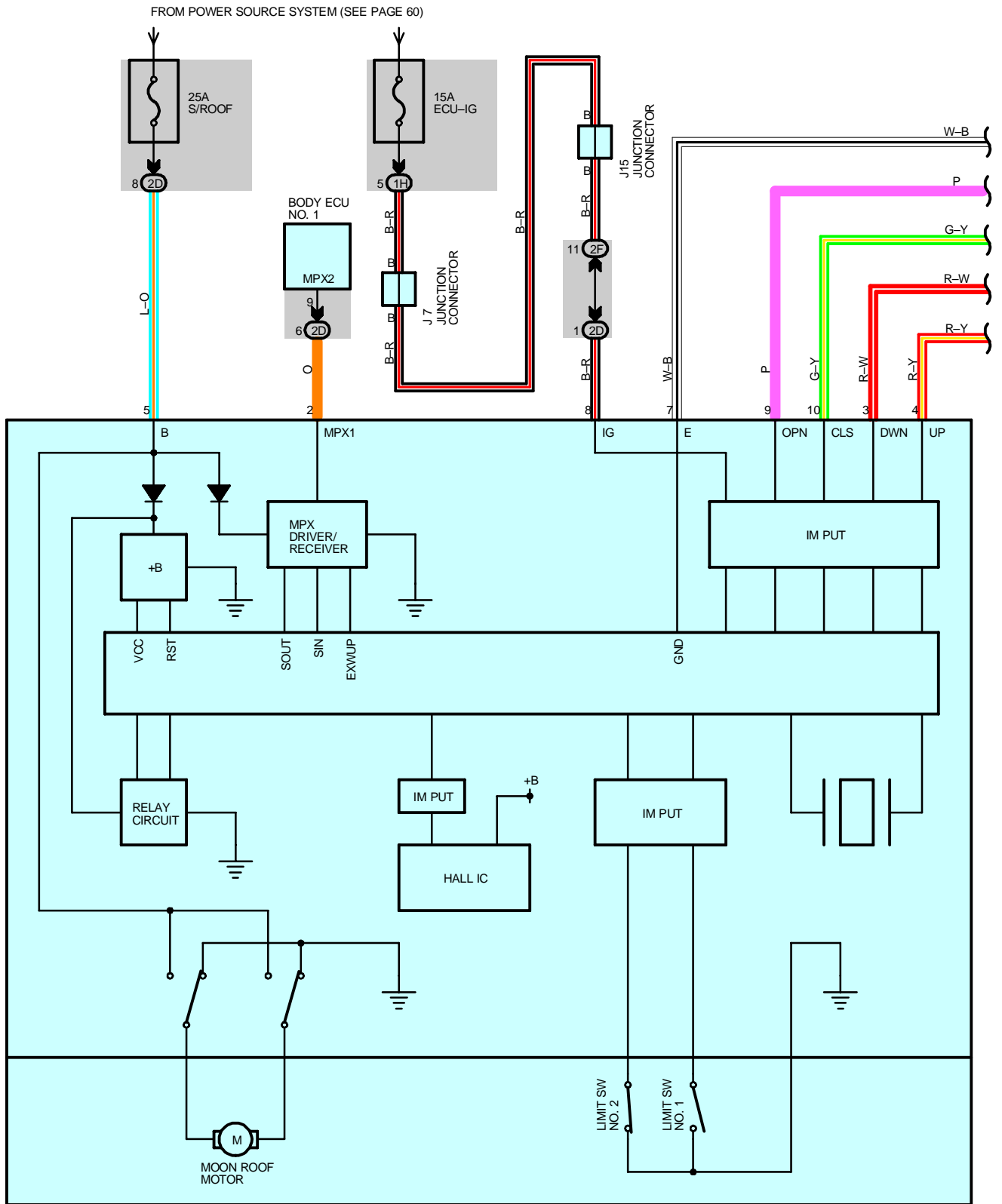

M 5
MOON ROOF CONTROL ECU

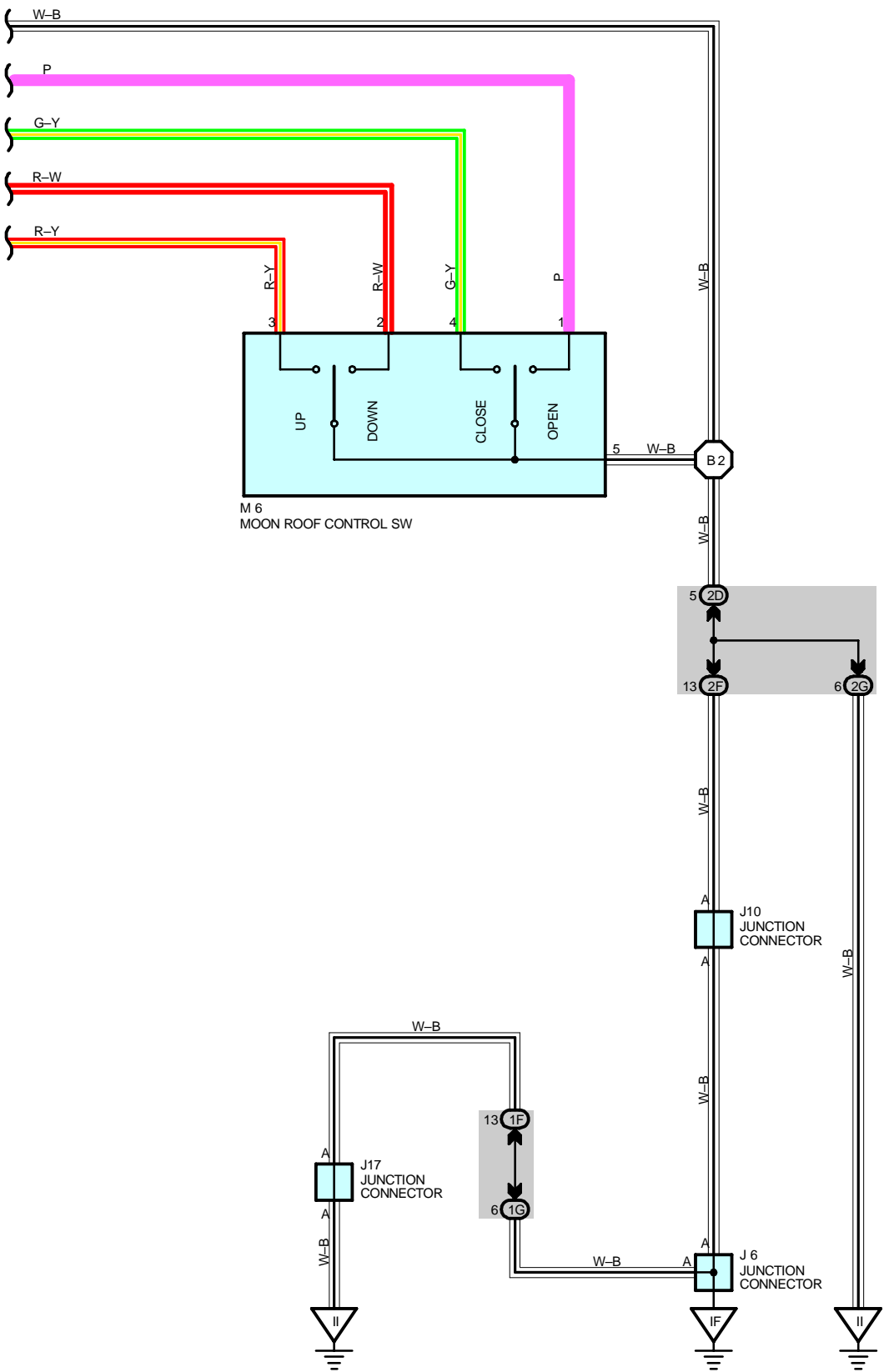

MOON ROOF

SYSTEM OUTLINE

In this system, the HALL IC in the moon roof control ECU detects changes in the motor rotation to allow opening/closing and tilting up/down of the moon roof using one touch operation. Additionally, catching prevention mechanism during moon roof operation is also provided.

Voltage is always applied from the S/ROOF fuse to TERMINAL 5 of the moon roof control ECU. When the ignition SW is turned to ON, the voltage is applied from the EUG-IG fuse to TERMINAL 8 of the moon roof control ECU.

1. SLIDE OPEN OPERATION

When the moon roof control SW is kept pressed to OPEN position for approximately 0.3 sec. or longer (The limit SW No.1 is off and limit SW No.2 is on), the signal is input from TERMINAL 1 of the moon roof control SW to TERMINAL 9 of the moon roof control ECU. This activates the ECU and rotates the motor to open the moon roof. After that, when the limit SW No.1 is turned on, and then turned off again, the pulse signal sent from the HALL IC activates the ECU, and it determines that the moon roof is fully opened, and stops the motor rotation. If other operation SW or open SW is operated while the moon roof is being opened, the ECU is activated to stop the moon roof operation. Additionally, when the moon roof is tilted up, the slide open operation does not function.

2. SLIDE CLOSE OPERATION

When the moon roof control SW is kept pressed to CLOSE position for approximately 0.3 sec. or longer (The limit SW No.1 is off and limit SW No.2 is off), the signal is input from TERMINAL 4 of the moon roof control SW to TERMINAL 10 of the moon roof control ECU. This activates the ECU and rotates the motor to automatically close the moon roof. After that, when the limit SW No.2 is turned on, the pulse signal sent from the HALL IC activates the ECU, and it determines that the moon roof is fully closed, and stops the motor rotation. If other operation SW or close SW is operated while the moon roof is being closed, the ECU is activated to stop the moon roof operation.

3. TILT UP OPERATION

When the moon roof control SW is kept pressed to TILT UP position for approximately 0.3 sec. or longer (The limit SW No.1 is off and limit SW No.2 is on), the signal is input from TERMINAL 3 of the moon roof control SW to TERMINAL 4 of the moon roof control ECU. This activates the ECU and rotates the motor to automatically tilt up the moon roof. If the pulse signal sent from the HALL IC is not input for 0.5 sec. or longer when the moon roof is fully tilted up, the ECU determines that the motor has stopped, and stops the current flowing into the motor.

If other operation SW or tilt up SW is operated while the moon roof is being tilted up, the ECU is activated to stop the moon roof operation. Additionally, when the moon roof is open, the tilt up operation does not function.

4. TILT DOWN OPERATION

When the moon roof control SW is kept pressed to TILT DOWN position for approximately 0.3 sec. or longer (The limit SW No.1 is on and limit SW No.2 is on), the signal is input from TERMINAL 2 of the moon roof control SW to TERMINAL 3 of the moon roof control ECU. This activates the ECU and rotates the motor to automatically tilt down the moon roof. When the limit SW No.1 is turned off, the pulse signal sent from the HALL IC activates the ECU, and it determines that the moon roof is fully closed, and stops the motor rotation.

If other operation SW or tilt down SW is operated while the moon roof is being tilted down, the ECU is activated to stop the moon roof operation.

5. CATCHING PREVENTION FUNCTION

If the moon roof control ECU detects a catching load from changes in the motor rotation during slide close or tilt down operation, the operation is stopped, and then the motor is rotated in the reverse direction.

Slide close operation

The moon roof is moved approximately 200 mm in the reverse direction (Slide open) after a catching load has been detected. However, if the full open position is detected before moving approximately 200 mm completely, the reverse movement is stopped.

Tilt down operation

If a catching load is detected during tilt down operation, the moon roof is fully tilted up.

6. KEY OFF MOON ROOF OPERATION

After the ignition SW is turned from ON to OFF, communication control of the body ECU and door ECU etc. allows the moon roof operation for 45 sec. However, when the driver or front passenger door is opened during above moon roof operation, the moon roof operation is stopped even though 45 sec. have not elapsed.

7. MOON ROOF OPERATION LINKED WITH TRANSMITTER

When the unlock SW on the transmitter of the ignition key is kept pressed for 1.5 sec. or longer, the slide open operation of the moon roof functions through communication control of the body ECU and door ECU etc.

8. MOON ROOF OPERATION LINKED WITH DOOR KEY LOCK AND UNLOCK SW

When the ignition key is inserted into the driver door key cylinder and kept turned to the lock or unlock position for approximately 1.5 sec. or longer, the slide open or close operation of the moon roof functions through communication control of the body ECU and door ECU etc.

9. FAIL SAFE FUNCTION

If the moon roof is operated continuously in the same operating direction, the current flowing into the motor is cut off when the time shown below has elapsed after the motor operation has been started.

Slide open/close operation with the moon roof control SW Approximately 20 sec.

Tilt up/down operation with the moon roof control SW Approximately 2 sec.

Slide open operation for reverse movement in case of activation of the catching prevention function Approximately 20 sec.

Tilt open operation for reverse movement in case of activation of the catching prevention function Approximately 2 sec.

SERVICE HINTS

M5 MOON ROOF CONTROL ECU

5-GROUND : Always approx. 12 volts

8-GROUND : Approx. 12 volts with ignition SW at **ON** or **ST** position

7-GROUND : Always continuity

M6 MOON ROOF CONTROL SW

3-5 : Closed with moon roof control SW at **TILT UP** position

2-5 : Closed with moon roof control SW at **TILT DOWN** position

1-5 : Closed with moon roof control SW at **OPEN** position

4-5 : Closed with moon roof control SW at **CLOSE** position

5-GROUND : Always continuity

○ : PARTS LOCATION

Code	See Page	Code	See Page	Code	See Page
J6	41	J15	41	M6	43
J7	41	J17	41		
J10	41	M5	43		

○ : JUNCTION BLOCK AND WIRE HARNESS CONNECTOR

Code	See Page	Junction Block and Wire Harness (Connector Location)
1F	26	Cowl Wire and Driver Side J/B (Left Kick Panel)
1G	27	
1H		
2D	28	Roof Wire and Passenger Side J/B (Right Kick Panel)
2F	28	Cowl Wire and Passenger Side J/B (Right Kick Panel)
2G	29	

▽ : GROUND POINTS

Code	See Page	Ground Points Location
IF	50	Left Kick Panel
II	50	Right Side of the Cowl Panel

○ : SPLICE POINTS

Code	See Page	Wire Harness with Splice Points	Code	See Page	Wire Harness with Splice Points
B2	54	Roof Wire			

MOON ROOF

J6

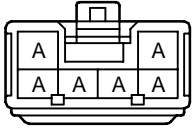

(Hint : See Page 7)

J7
GRAY

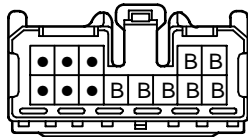

(Hint : See Page 7)

J10
ORANGE

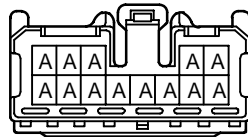

(Hint : See Page 7)

J15

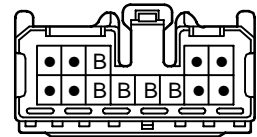

(Hint : See Page 7)

J17

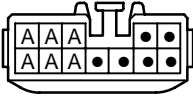

(Hint : See Page 7)

M5

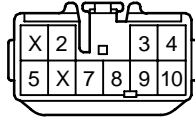

M6

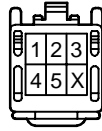

MULTIPLEX COMMUNICATION SYSTEM (COMMUNICATION BUS)

* 1 : W/ LEXUS NAVIGATION SYSTEM
 * 2 : W/O LEXUS NAVIGATION SYSTEM

* 3 : W/ DRIVING POSITION MEMORY
 * 4 : W/O DRIVING POSITION MEMORY

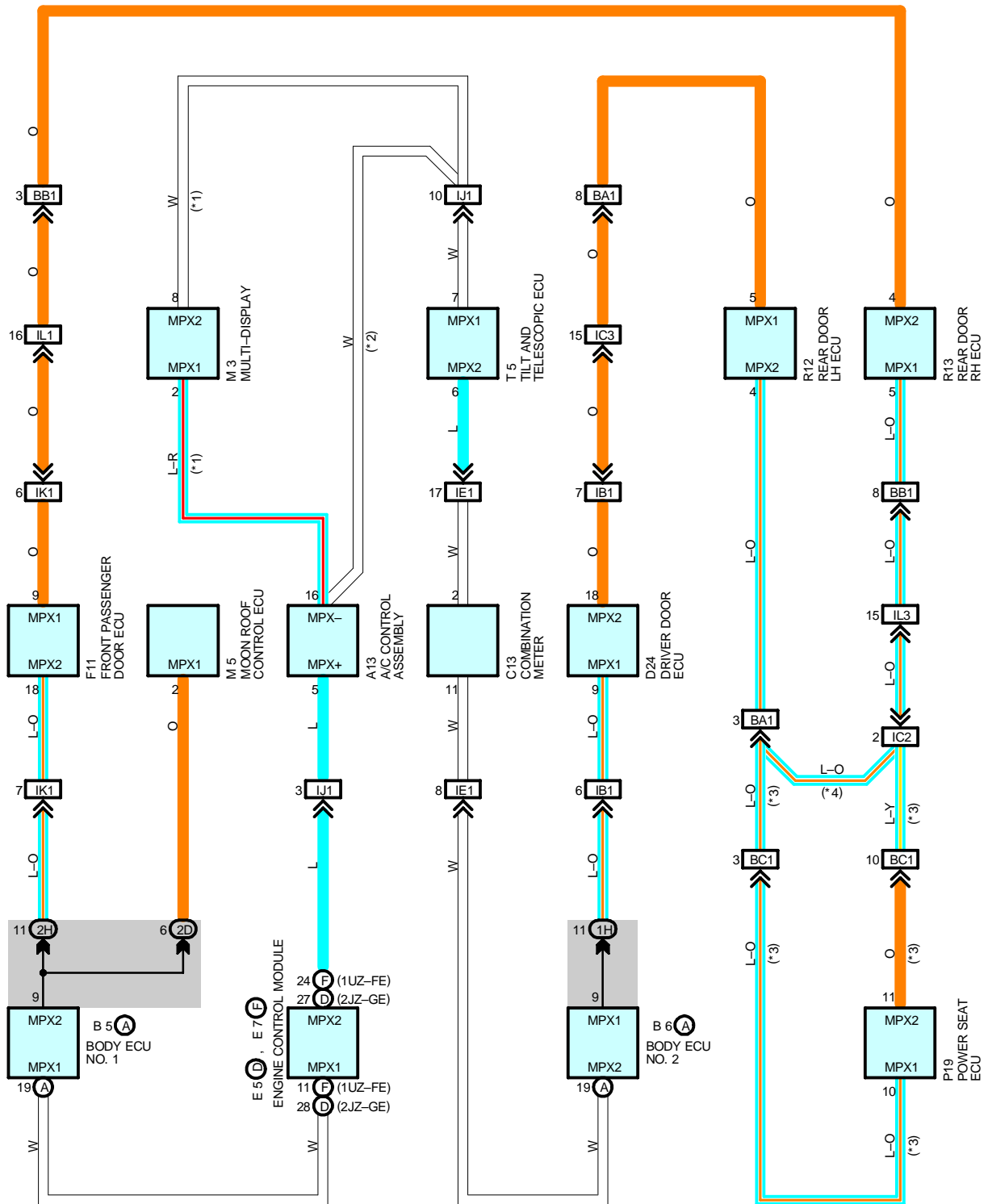

MULTIPLEX COMMUNICATION SYSTEM INCLUDES FOLLOWING SYSTEMS

- * **AUTOMATIC AIR CONDITIONING**
- * **AUTOMATIC LIGHT CONTROL**
- * **CHARGING**
- * **COMBINATION METER**
- * **CRUISE CONTROL (1UZ-FE)**
- * **CRUISE CONTROL (2JZ-GE)**
- * **ELECTRONICALLY CONTROLLED TRANSMISSION (1UZ-FE)**
- * **ELECTRONICALLY CONTROLLED TRANSMISSION (2JZ-GE)**
- * **ENGINE CONTROL (1UZ-FE)**
- * **ENGINE CONTROL (2JZ-GE)**
- * **HEADLIGHT**
- * **INTERIOR LIGHT**
- * **KEY REMINDER AND SEAT BELT WARNING**
- * **LEXUS NAVIGATION SYSTEM**
- * **LIGHT AUTO TURN OFF**
- * **MOON ROOF**
- * **POWER SEAT (DRIVER'S SEAT w/ DRIVING POSITION MEMORY)**
- * **POWER TILT AND POWER TELESCOPIC**
- * **POWER WINDOW**
- * **REAR WINDOW DEFOGGER AND MIRROR HEATER**
- * **REMOTE CONTROL MIRROR**
- * **STOP LIGHT**
- * **TAILLIGHT**
- * **THEFT DETERRENT AND DOOR LOCK CONTROL**
- * **VSC**
- * **WIRELESS DOOR LOCK CONTROL**

MULTIPLEX COMMUNICATION SYSTEM

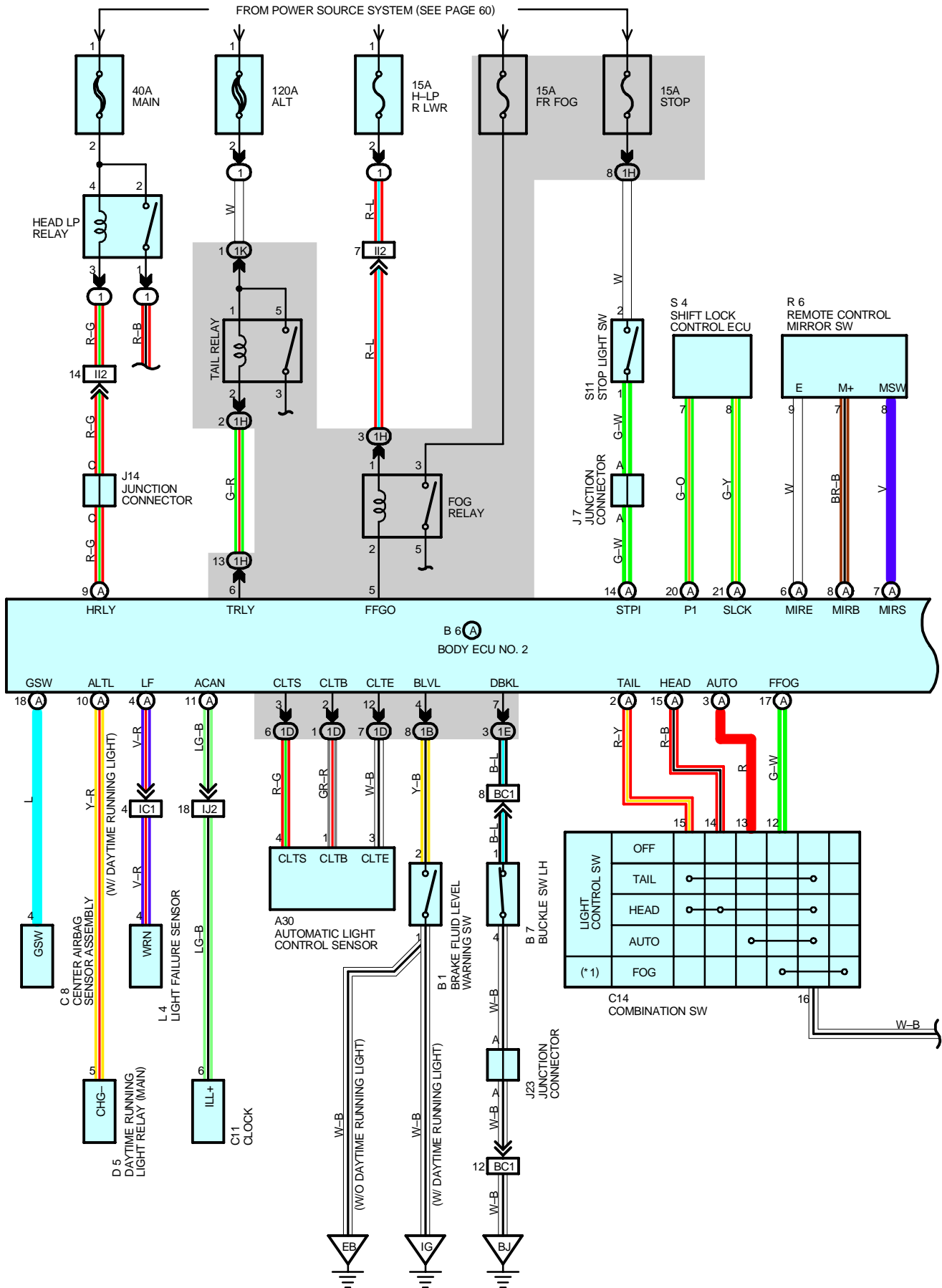

FROM POWER SOURCE SYSTEM (SEE PAGE 60)

* 1 : FOG LIGHT SW

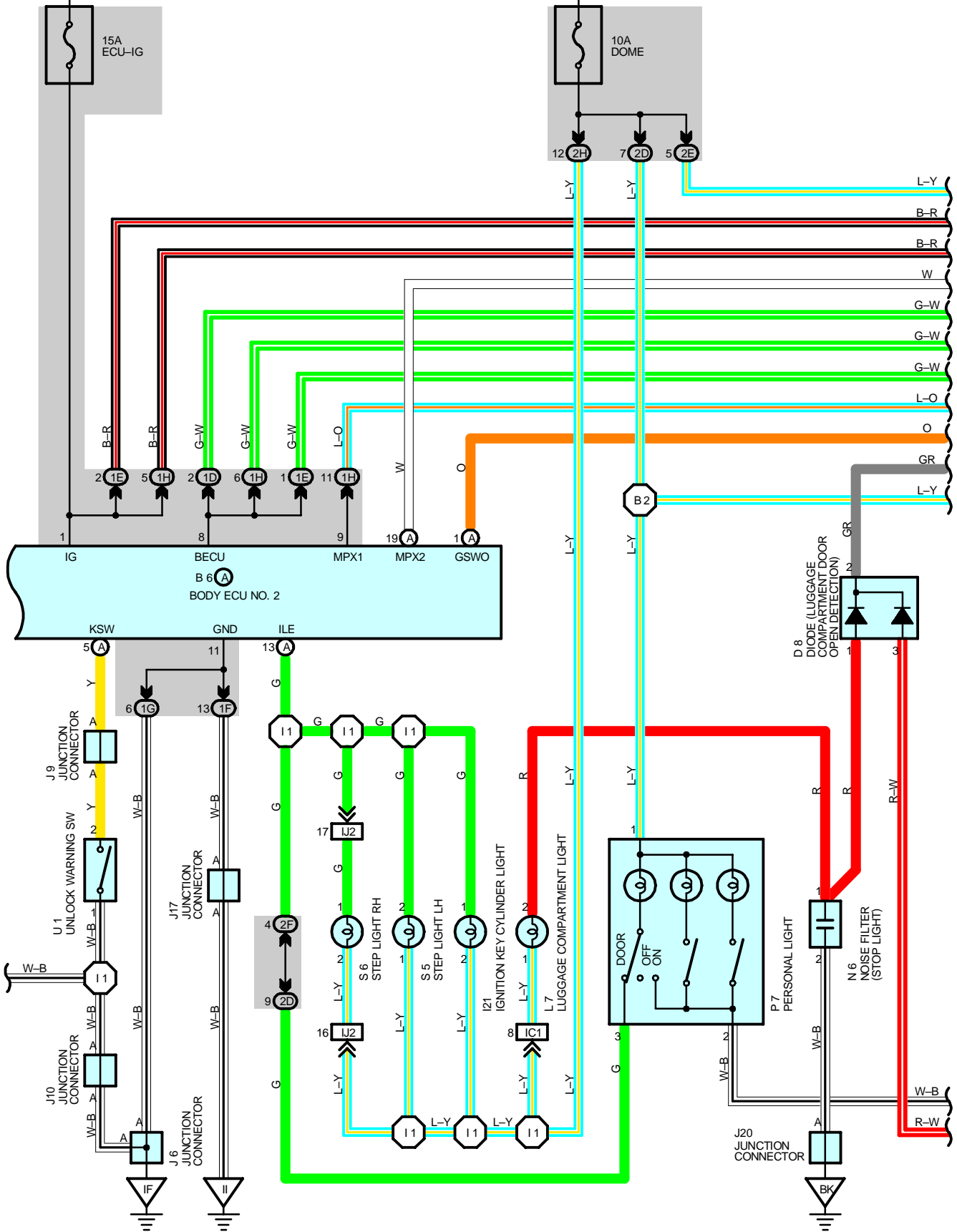

MULTIPLEX COMMUNICATION SYSTEM

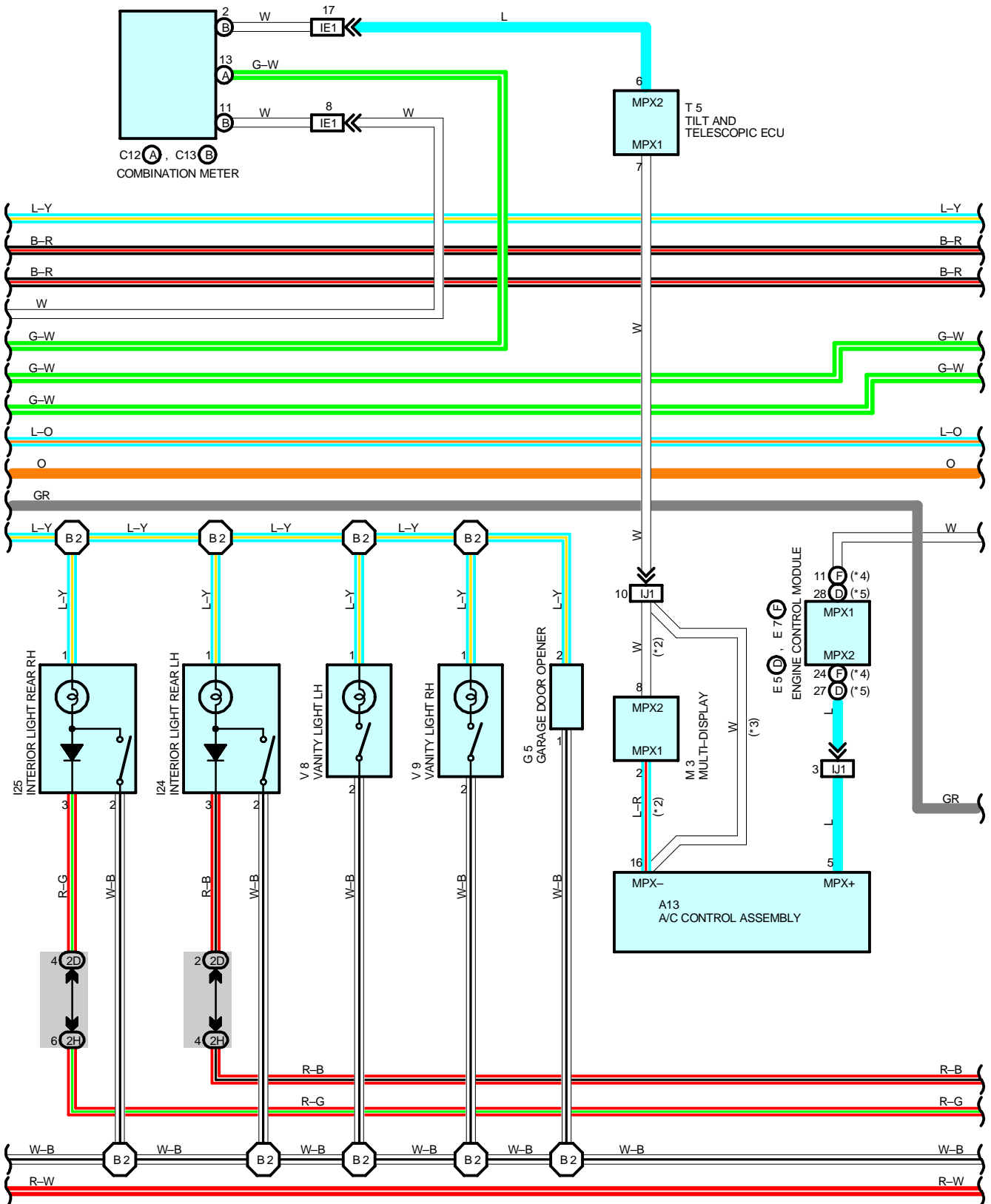

FROM POWER SOURCE SYSTEM (SEE PAGE 60)

- * 2 : W/ LEXUS NAVIGATION SYSTEM
- * 3 : W/O LEXUS NAVIGATION SYSTEM
- * 4 : 1UZ-FE
- * 5 : 2JZ-GE

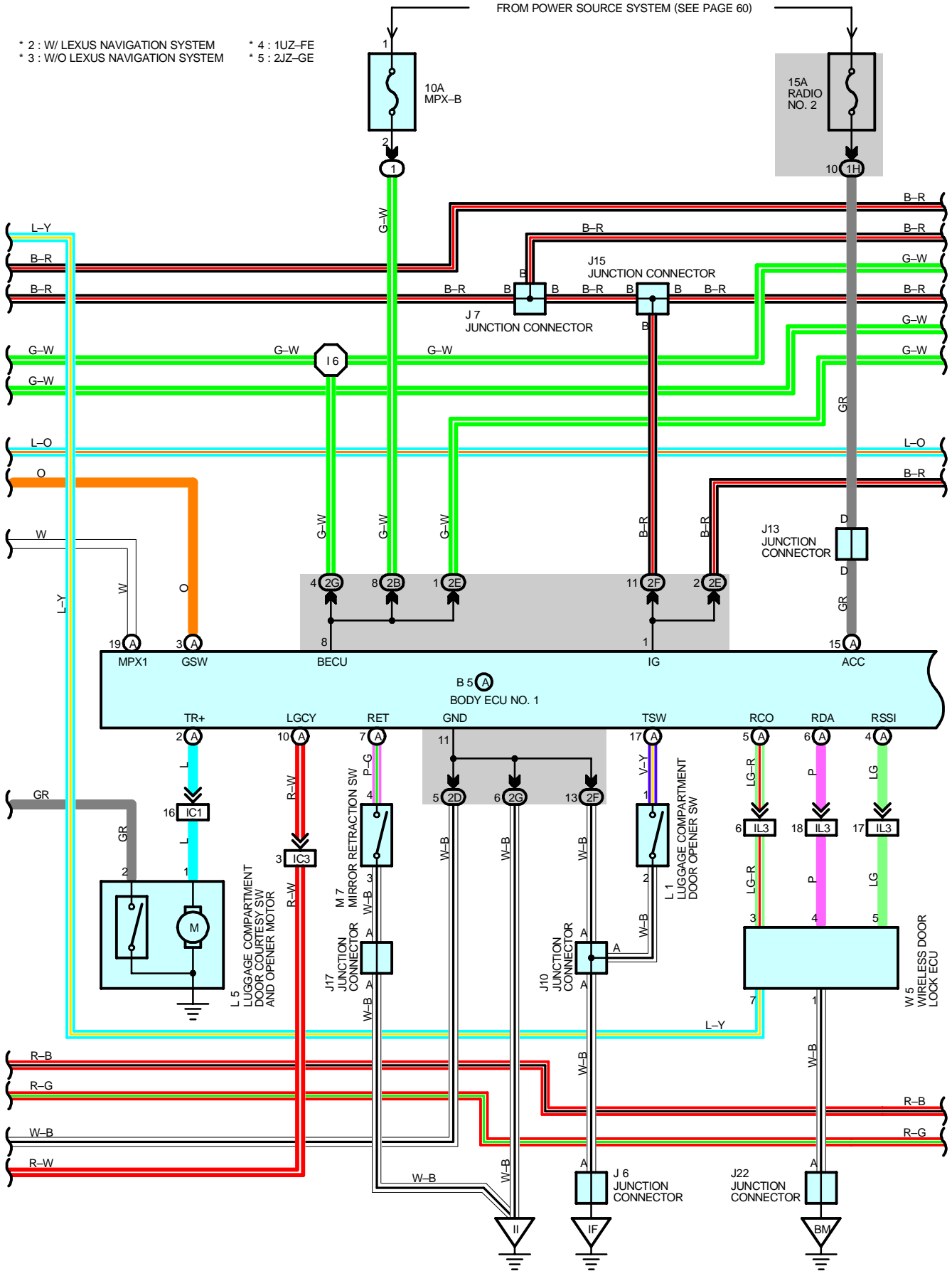

MULTIPLEX COMMUNICATION SYSTEM

FROM POWER SOURCE SYSTEM (SEE PAGE 60)

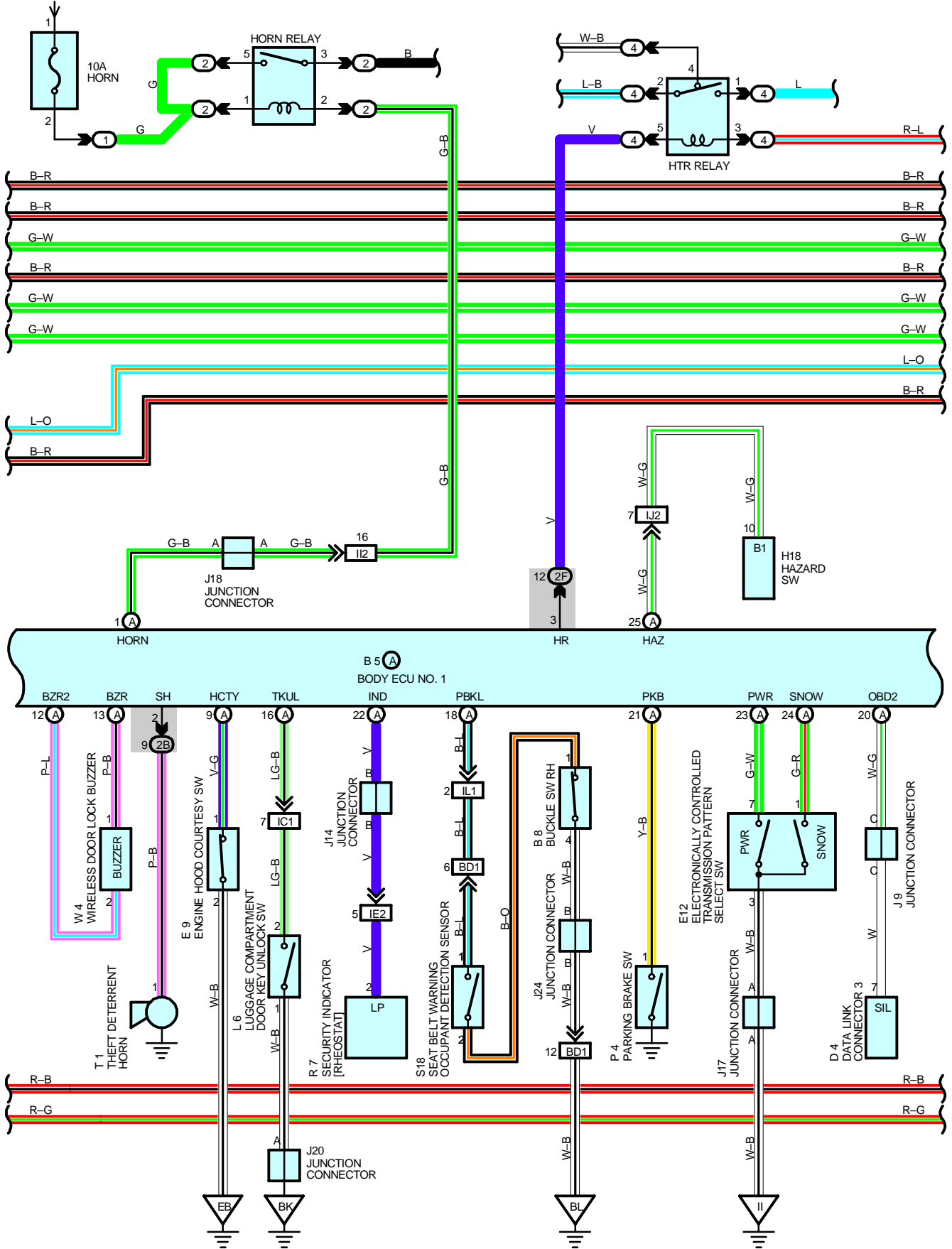

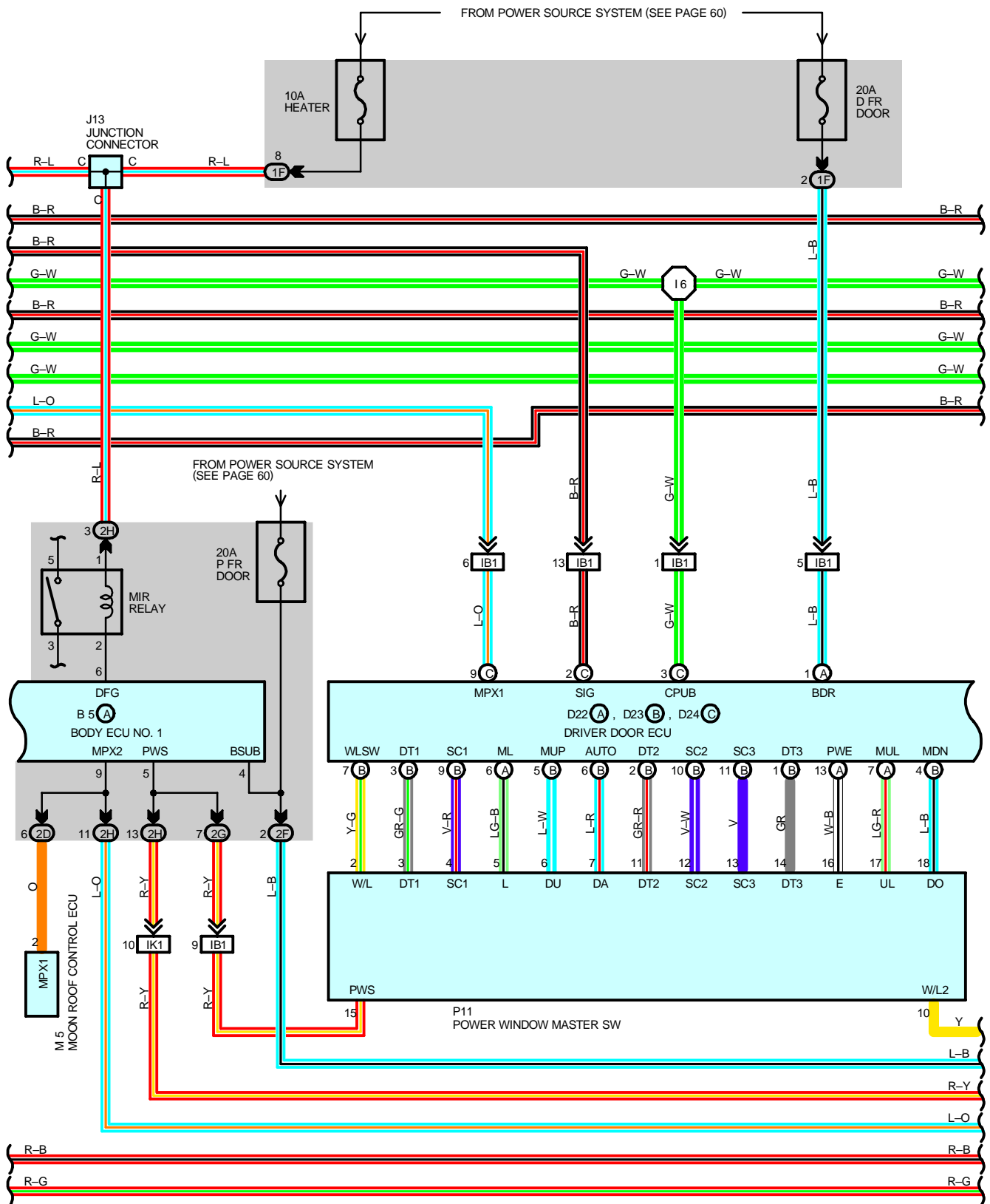

MULTIPLEX COMMUNICATION SYSTEM

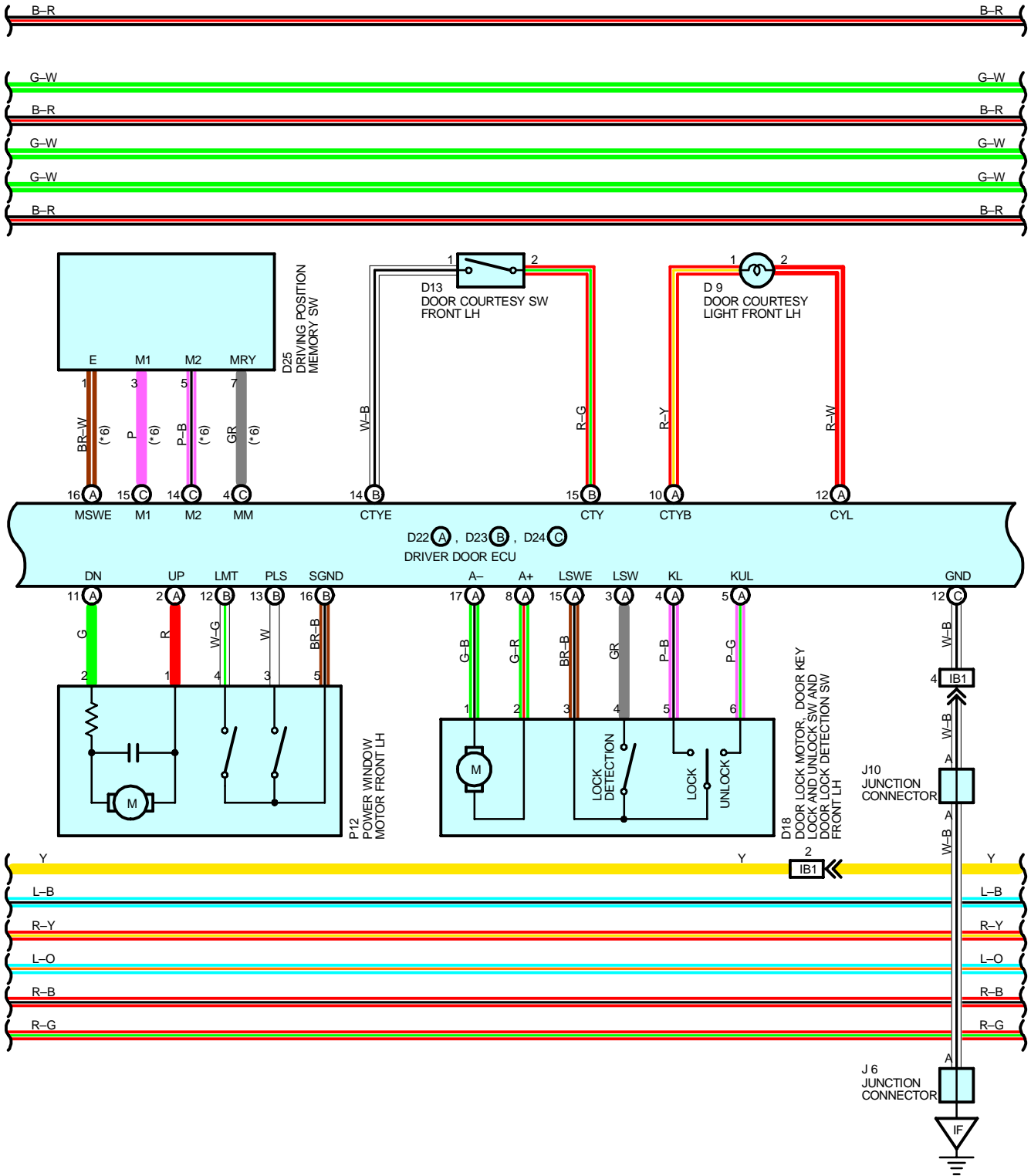

- * 6 : W/ DRIVING POSITION MEMORY
- * 7 : W/O DRIVING POSITION MEMORY
- * 8 : W/ RETRACTION

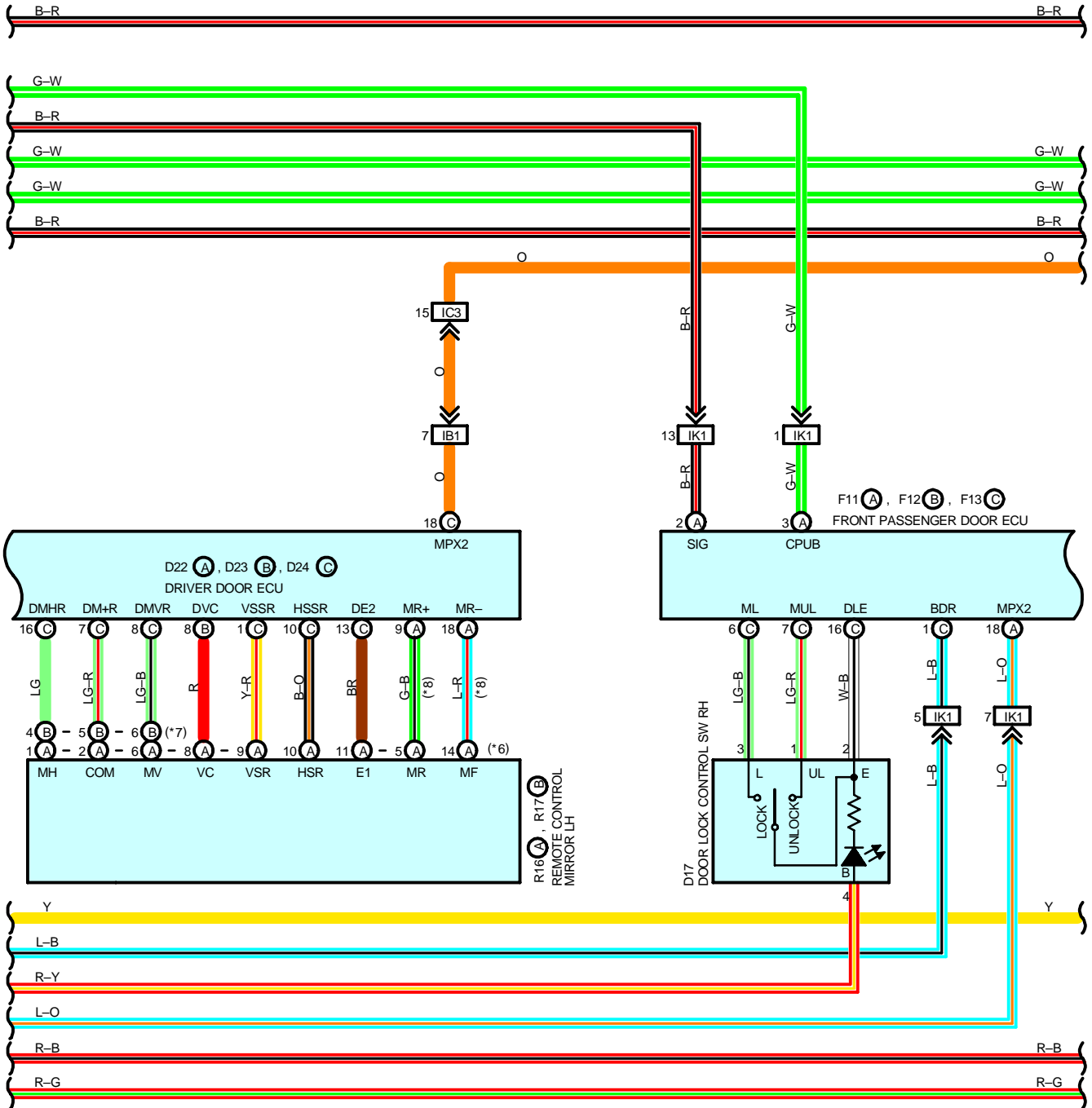

MULTIPLEX COMMUNICATION SYSTEM

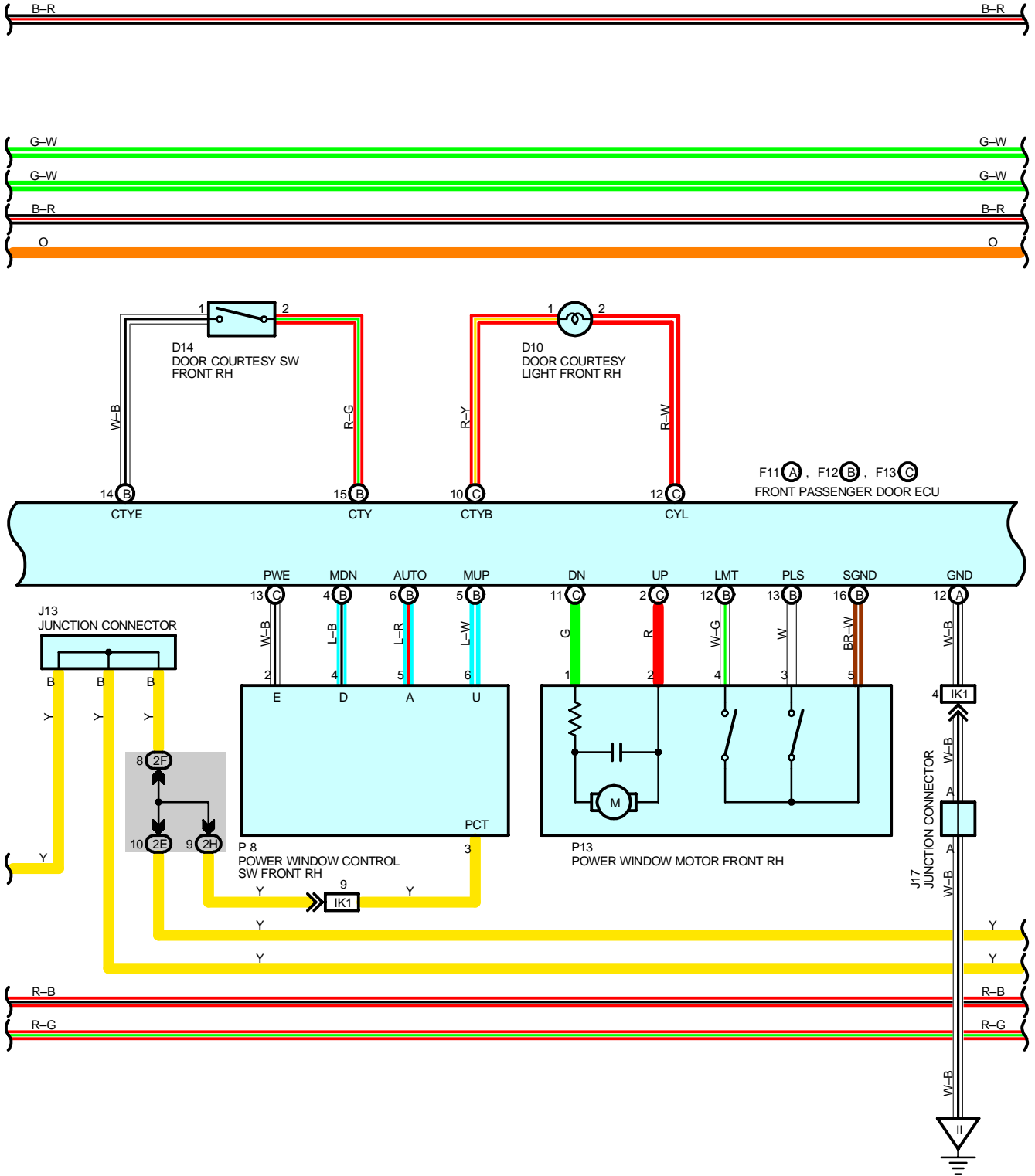

- * 6 : W/ DRIVING POSITION MEMORY
- * 7 : W/O DRIVING POSITION MEMORY
- * 8 : W/ RETRACTION

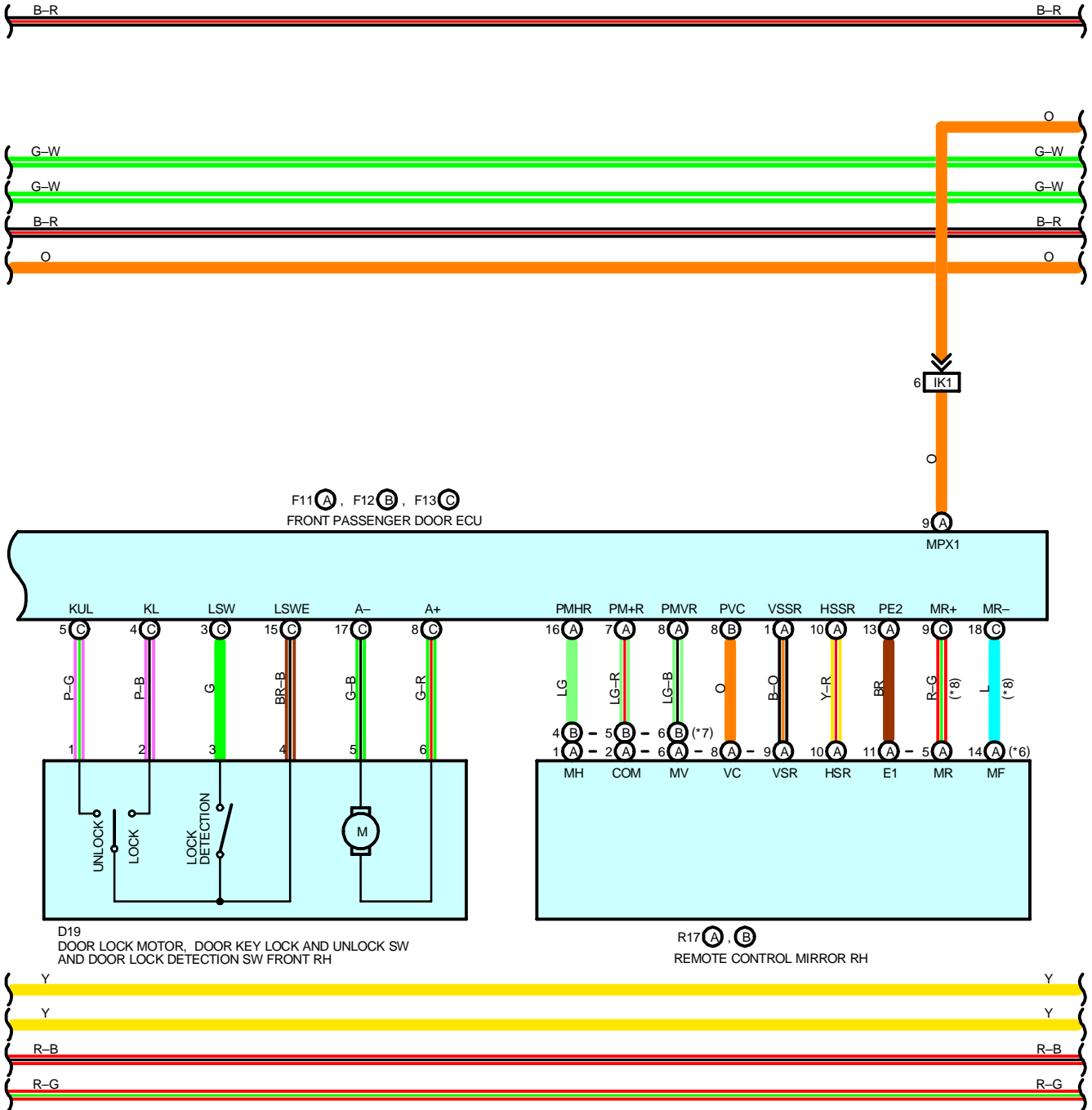

MULTIPLEX COMMUNICATION SYSTEM

FROM POWER SOURCE SYSTEM (SEE PAGE 60)

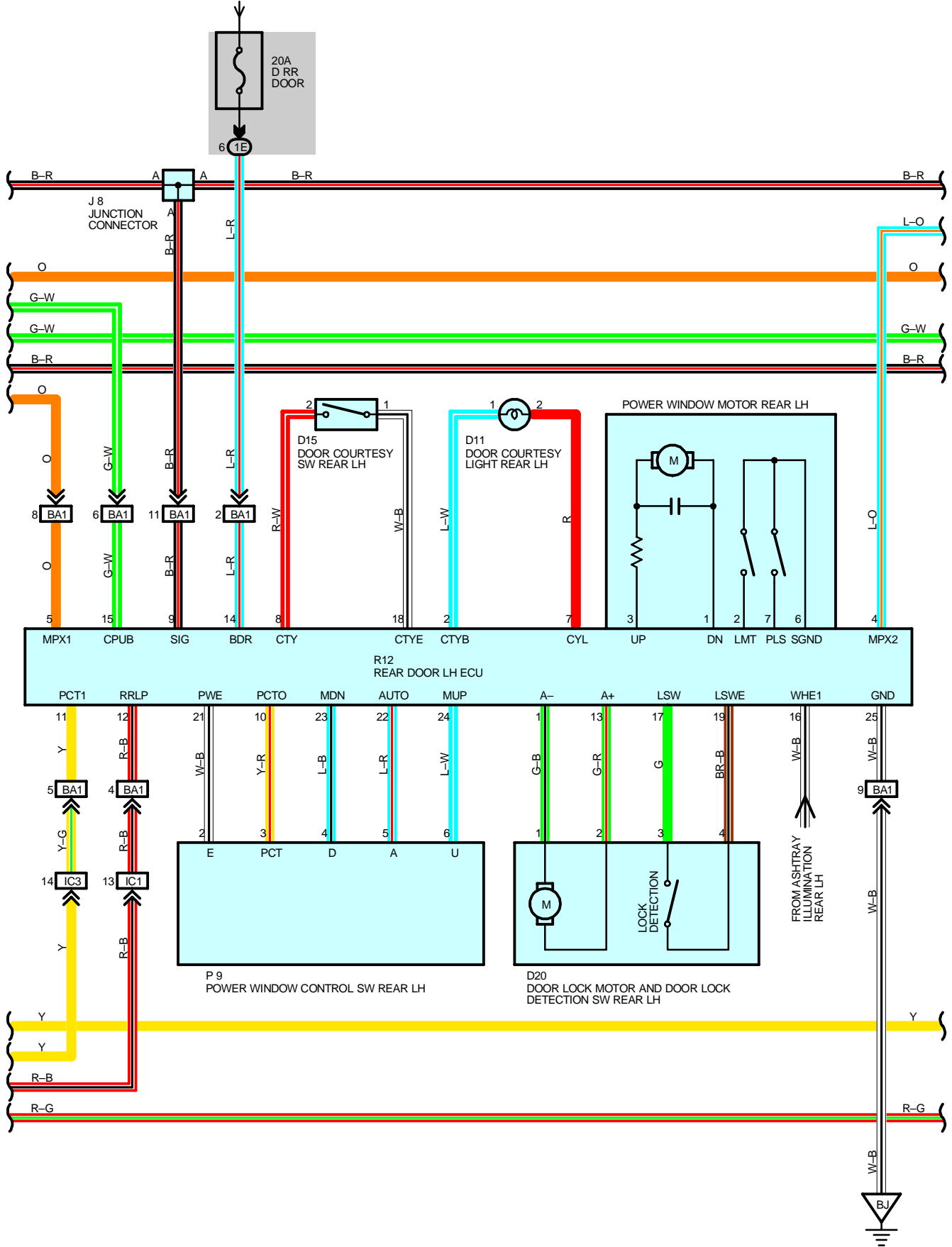

FROM POWER SOURCE SYSTEM (SEE PAGE 60)

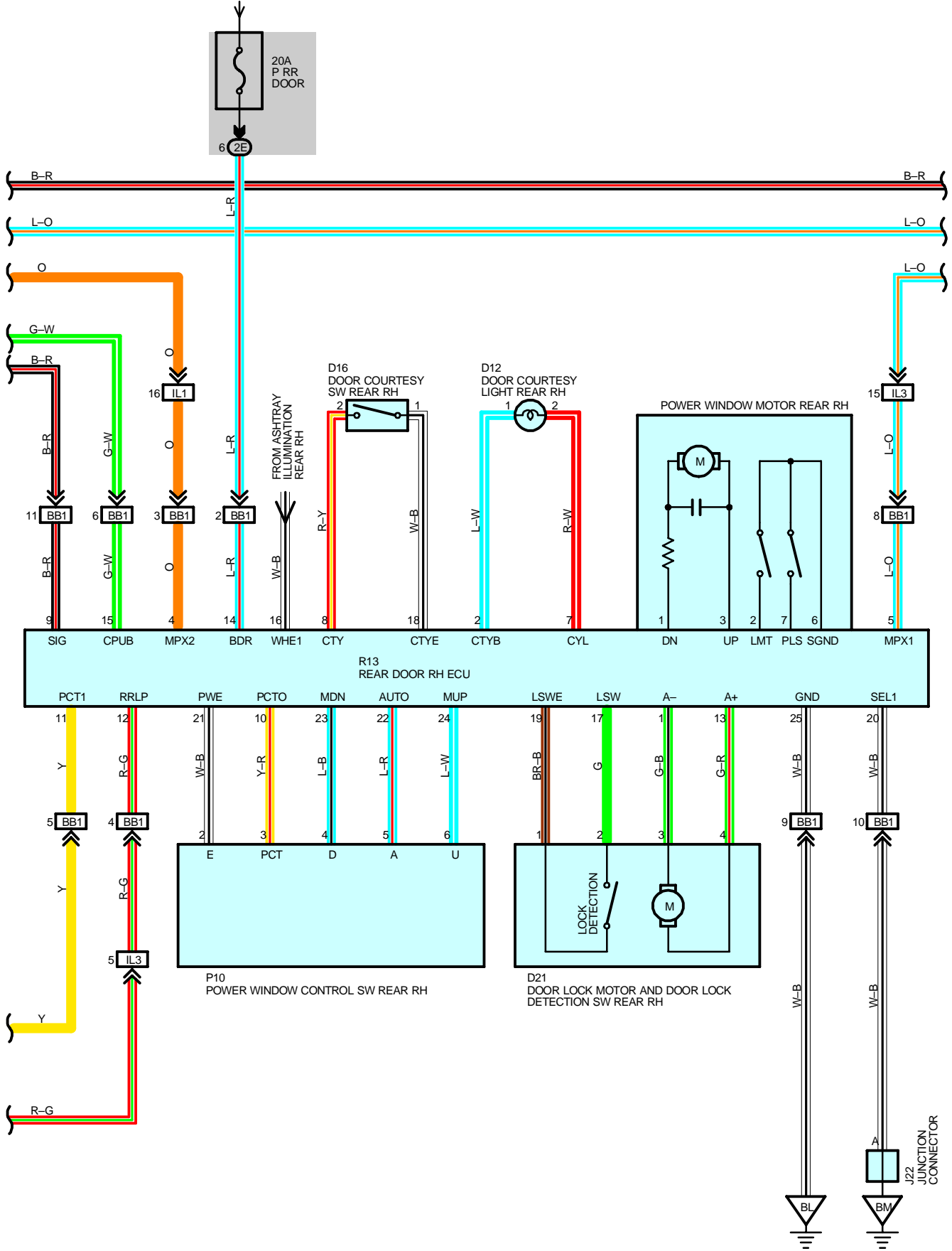

MULTIPLEX COMMUNICATION SYSTEM

FROM POWER SOURCE SYSTEM (SEE PAGE 60)

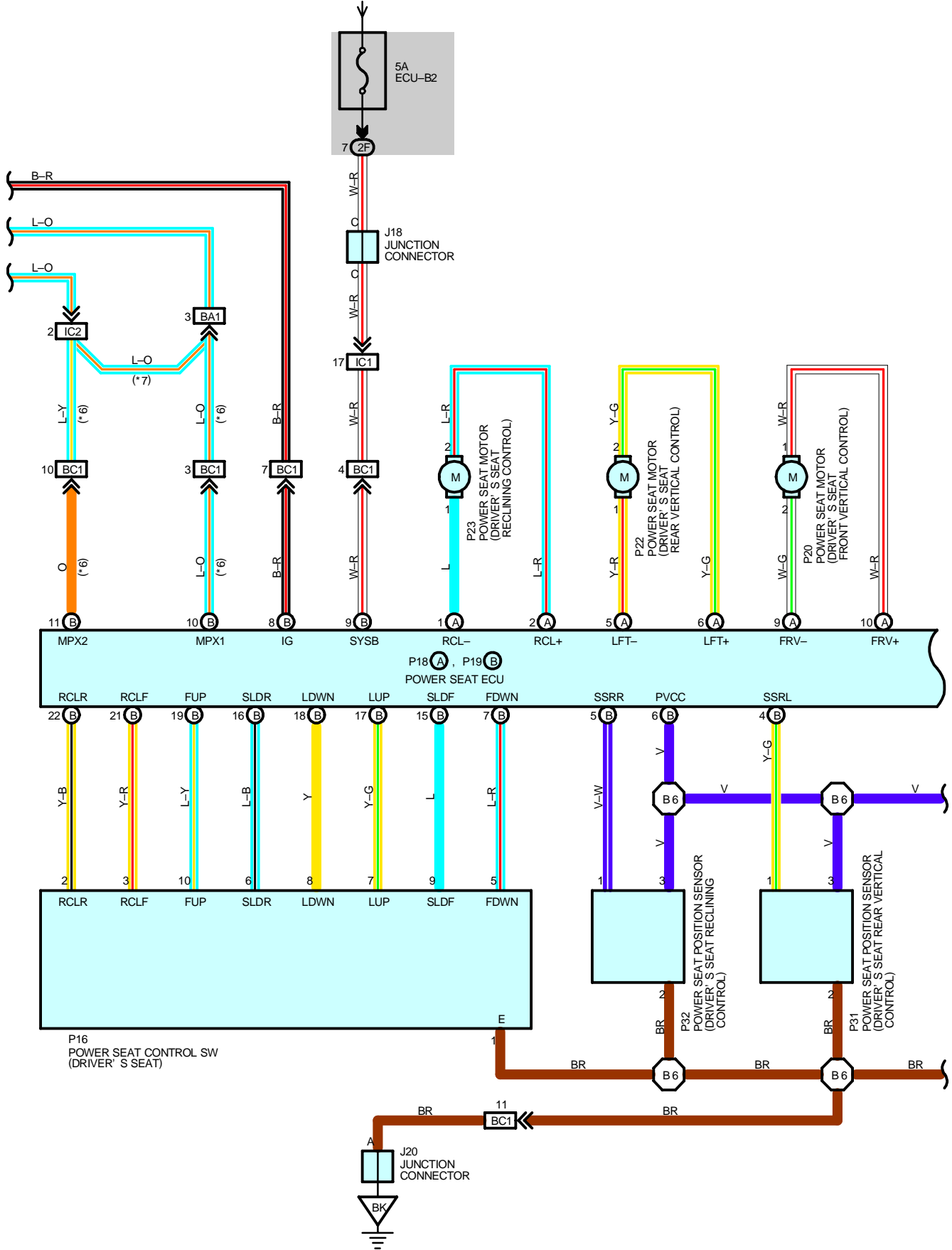

FROM POWER SOURCE SYSTEM (SEE PAGE 60)

- * 6 : W/ DRIVING POSITION MEMORY
- * 7 : W/O DRIVING POSITION MEMORY

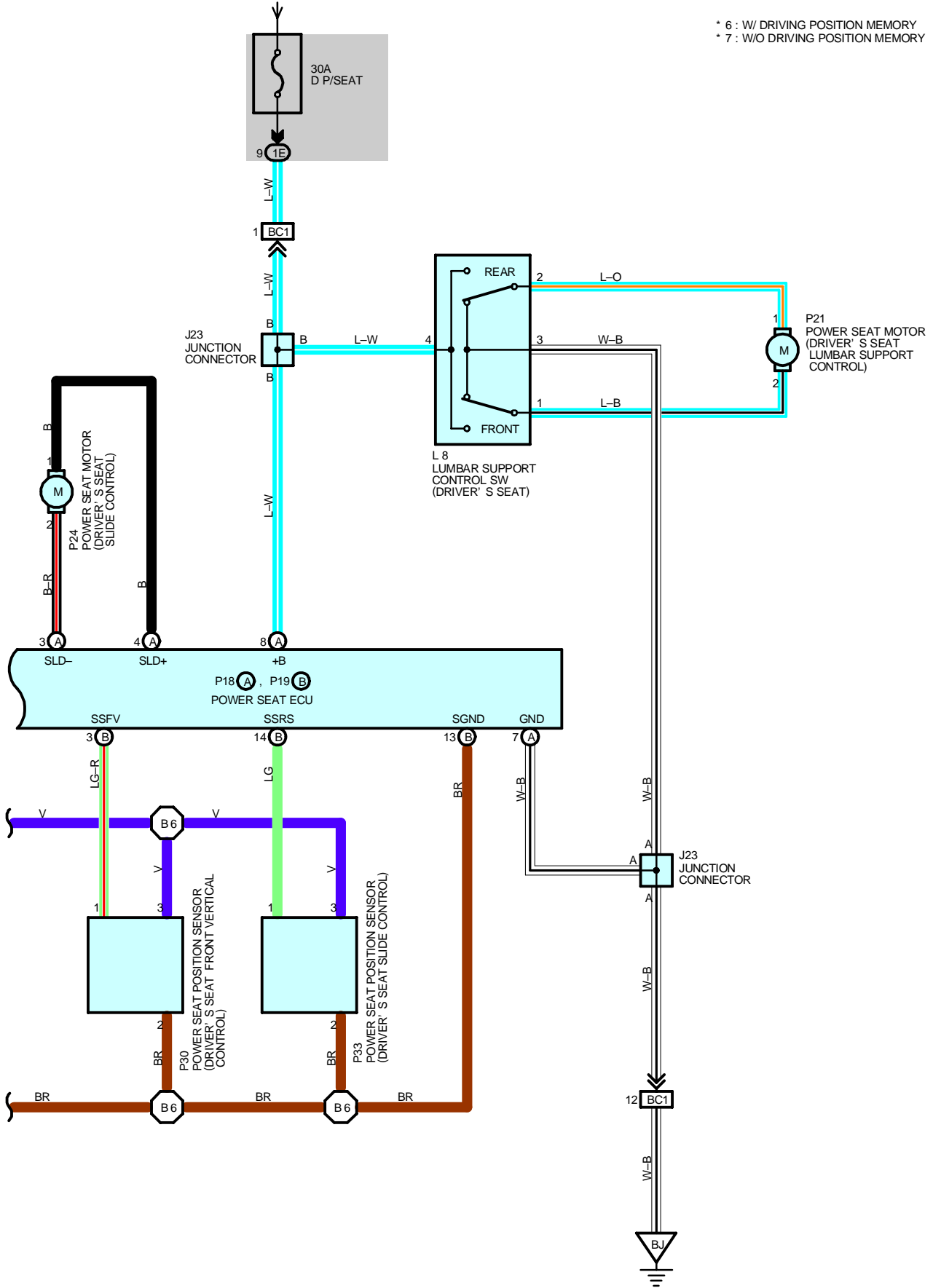

MULTIPLEX COMMUNICATION SYSTEM

SYSTEM OUTLINE

MULTIPLEX COMMUNICATION SYSTEM

The system is comprised of the communication modes of the body ECU No.1, body ECU No.2, driver door ECU, front passenger door ECU, rear door LH ECU, rear door RH ECU, engine control module, combination meter, A/C control assembly, navigation ECU, tilt and telescopic ECU, power seat ECU and moon roof control ECU. The body electrical systems are controlled by a serial communication in which each ECU is linked to another via a single communication line. This system is also equipped with a self-diagnosis function.

The table below shows the systems under the control of the MPX communication system and related ECUs (Communication nodes).

SYSTEM \ ECU	ECU												
	Body ECU No.1	Body ECU No.2	Driver Door ECU	Front Passenger Door ECU	Rear Door LH ECU	Rear Door RH ECU	Engine Control Module	Combination Meter	A/C Control Assembly	Navigation ECU	Tilt and Telescopic ECU	Power Seat ECU	Moon Roof Control ECU
Power Window	2	2	1	2	2	2	-	-	-	-	-	-	2
Theft Deterrent and Door Lock Control	1	2	2	2	2	2	-	2	-	-	-	-	-
Wireless Door Lock Control	1	2	2	2	2	2	-	-	-	-	-	-	2
Light Auto Turn Off	-	1	2	2	2	2	-	-	-	-	-	-	-
Automatic Light Control	-	1	2	-	-	-	-	1	-	-	-	-	-
Illuminated Entry	-	1	2	2	2	2	-	-	-	-	-	-	-
Key Reminder	-	1	2	-	-	-	-	-	-	-	-	-	-
Luggage Compartment Door Opener	1	-	-	-	-	-	-	-	-	-	-	-	-
Remote Control Mirror	2	2	1	1	-	-	-	-	-	-	-	-	-
Shift Lock	-	1	-	-	-	-	2	-	-	-	-	-	-
Fog Light	-	1	-	-	-	-	-	2	-	-	-	-	-
Memory System	-	-	2	2	-	-	-	-	-	-	2	1	-
Seat Belt Warning	2	2	-	-	-	-	-	1	-	-	-	-	-

1 : Master control

2 : Sub control

1. COMMUNICATION OUTLINE

Communication is implemented among the body No.1, No.2, driver door, front passenger door, tilt and telescopic, navigation, A/C control assembly, moon roof, power seat, engine control ECUs.

Upon receiving signals from applicable switches such as the door lock control switch or door courtesy light switch, each ECU determines the conditions of the switches as well as of the doors, and after converting this information into digital signals, outputs them to other ECUs via serial data communication. The ECU that receives these digital signals determines the conditions of the switches and doors so that it can implement various controls such as to activate a door lock motor.

However, if there are no changes in the input signals because no doors were opened and no switches were used within 30 seconds, the body ECU interrupts the communication to save electricity. Following this interruption, any changes in the input signals will cause the communication to resume.

For details please refer to the new car features and repair manuals.

SERVICE HINTS

BODY ECU NO.2

1-GROUND : Approx. 12 volts with ignition SW at **ON** or **ST** position

8-GROUND : Always approx. 12 volts

11-GROUND : Always continuity

B5 (A) BODY ECU NO.1

1-GROUND : Approx. 12 volts with ignition SW at **ON** or **ST** position

4-GROUND : Always approx. 12 volts

8-GROUND : Always approx. 12 volts

11-GROUND : Always continuity

(A)15-GROUND : Approx. 12 volts with ignition SW at **ACC** or **ON** position

D22 (A), D24 (C) DRIVER DOOR ECU

(C) 2-GROUND : Approx. 12 volts with ignition SW at **ON** or **ST** position

(C) 3-GROUND : Always approx. 12 volts

(A) 1-GROUND : Always approx. 12 volts

(C)12-GROUND : Always continuity

F11 (A), F13 (C) FRONT PASSENGER DOOR ECU

(A) 2-GROUND : Approx. 12 volts with ignition SW at **ON** or **ST** position

(A) 3-GROUND : Always approx. 12 volts

(C) 1-GROUND : Always approx. 12 volts

(A)12-GROUND : Always continuity

R12 REAR DOOR LH ECU

9-GROUND : Approx. 12 volts with ignition SW at **ON** or **ST** position

15-GROUND : Always approx. 12 volts

14-GROUND : Always approx. 12 volts

25-GROUND : Always continuity

R13 REAR DOOR RH ECU

9-GROUND : Approx. 12 volts with ignition SW at **ON** or **ST** position

15-GROUND : Always approx. 12 volts

14-GROUND : Always approx. 12 volts

20-GROUND : Always continuity

25-GROUND : Always continuity

MULTIPLEX COMMUNICATION SYSTEM

○ : PARTS LOCATION

Code	See Page	Code	See Page	Code	See Page		
A13	40	F11	A	42	P12	43	
A30	40	F12	B	42	P13	43	
B1	36 (1UZ-FE)	F13	C	42	P16	44	
	38 (2JZ-GE)	G5		42	P18	A	44
B5	A	40	H18	40	P19	B	44
B6	A	40	I21	41	P20		44
B7		44	I24	42	P21		44
B8		44	I25	42	P22		44
C8		40	J6	41	P23		44
C11		40	J7	41	P24		44
C12	A	40	J8	41	P30		44
C13	B	40	J9	41	P31		44
C14		40	J10	41	P32		44
D4		40	J13	41	P33		44
D5		40	J14	41	R6		41
D8		42	J15	41	R7		41
D9		42	J17	41	R12		43
D10		42	J18	41	R13		43
D11		42	J20	42	R16	A	43
D12		42	J22	42		B	43
D13		42	J23	44	R17	A	43
D14		42	J24	44		B	43
D15		42	L1	41	S4		41
D16		42	L4	43	S5		41
D17		42	L5	43	S6		41
D18		42	L6	43	S11		41
D19		42	L7	43	S18		44
D20		42	L8	44	T1		37 (1UZ-FE)
D21		42	M3	41			
D22	A	42	M5	43	T5		41
D23	B	42	M7	41	U1		41
D24	C	42	N6	43	V8		43
D25		42	P4	41	V9		43
E5	D	38 (2JZ-GE)	P7	43	W4		37 (1UZ-FE)
E7	F	36 (1UZ-FE)	P8	43			
E9		36 (1UZ-FE)	P9	43	W5		43
		38 (2JZ-GE)	P10	43			
E12		40	P11	43			

○ : RELAY BLOCKS

Code	See Page	Relay Blocks (Relay Block Location)
1	22	Engine Room No.1 R/B (Engine Compartment Right)
2	23	Engine Room No.2 R/B (Engine Compartment Left)
4	25	Passenger Side R/B (Right Kick Panel)

 : JUNCTION BLOCK AND WIRE HARNESS CONNECTOR

Code	See Page	Junction Block and Wire Harness (Connector Location)
1B	26	Cowl Wire and Driver Side J/B (Left Kick Panel)
1D	26	Instrument Panel Wire and Driver Side J/B (Left Kick Panel)
1E	26	Floor No.2 Wire and Driver Side J/B (Left Kick Panel)
1F	26	Cowl Wire and Driver Side J/B (Left Kick Panel)
1G	27	
1H		
1K	26	Engine Room Main Wire and Driver Side J/B (Left Kick Panel)
2B	28	Engine Room Main Wire and Passenger Side J/B (Right Kick Panel)
2D	28	Roof Wire and Passenger Side J/B (Right Kick Panel)
2E	28	Floor No.1 Wire and Passenger Side J/B (Right Kick Panel)
2F	28	Cowl Wire and Passenger Side J/B (Right Kick Panel)
2G	29	
2H		

 : CONNECTOR JOINING WIRE HARNESS AND WIRE HARNESS

Code	See Page	Joining Wire Harness and Wire Harness (Connector Location)
IB1	50	Front Door LH Wire and Cowl Wire (Left Kick Panel)
IC1	50	Floor No.2 Wire and Cowl Wire (Left Kick Panel)
IC2		
IC3		
IE1	50	Instrument Panel Wire and Cowl Wire (Left Side of the Steering Column)
IE2		
II2	52	Engine Room Main Wire and Cowl Wire (Near the Passenger Side R/B)
IJ1	52	Instrument Panel Wire and Cowl Wire (Left Side of the Blower Unit)
IJ2		
IK1	52	Front Door RH Wire and Cowl Wire (Right Kick Panel)
IL1	52	Floor No.1 Wire and Cowl Wire (Right Kick Panel)
IL3		
BA1	54	Rear Door LH Wire and Floor No.2 Wire (Under the Center Pillar LH)
BB1	54	Rear Door RH Wire and Floor No.1 Wire (Under the Center Pillar RH)
BC1	56	Floor No.2 Wire and Front Seat LH Wire (Under the Driver's Seat)
BD1	56	Floor No.1 Wire and Front Seat RH Wire (Under the Front Passenger's Seat)

 : GROUND POINTS

Code	See Page	Ground Points Location
EB	46 (1UZ-FE)	Left Fender
	48 (2JZ-GE)	
IF	50	Left Kick Panel
IG	50	Left Side of the Cowl Panel
II	50	Right Side of the Cowl Panel
BJ	54	Rear Floor Partition Panel LH
BK	54	Quarter Panel LH
BL	54	Rear Floor Partition Panel RH
BM	54	Quarter Panel RH

 : SPLICE POINTS

Code	See Page	Wire Harness with Splice Points	Code	See Page	Wire Harness with Splice Points
I1	52	Cowl Wire	B2	54	Roof Wire
I6			B6	56	Front Seat LH Wire

MULTIPLEX COMMUNICATION SYSTEM

A13

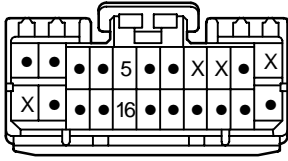

**A30
BLACK**

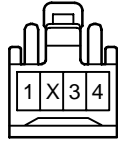

**B1
GRAY**



B5 (A)

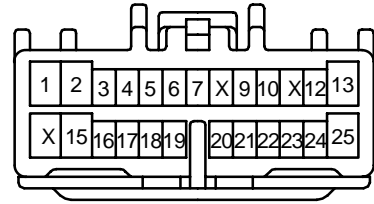

B6 (A)

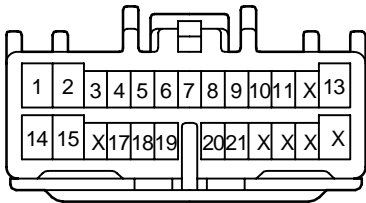

B7



B8

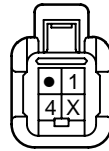

**C8
YELLOW**

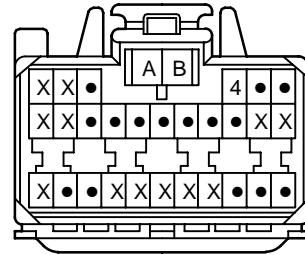

C11

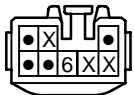

C12 (A)

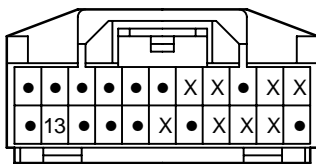

C13 (B)

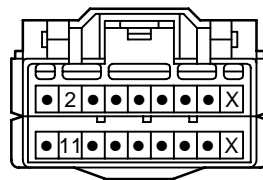

C14

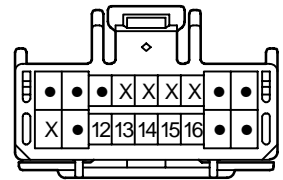

D4

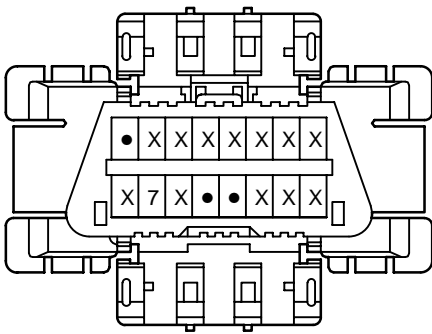

**D5
GRAY**

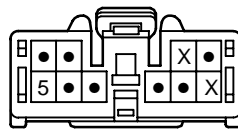

**D8
GRAY**

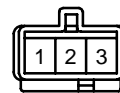

D9

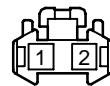

D10



D11



D12



**D13
GRAY**

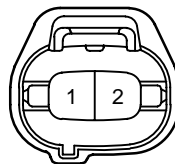

**D14
GRAY**

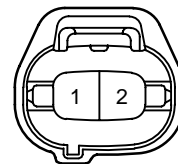

**D15
GRAY**

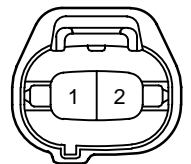

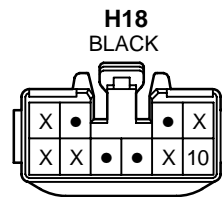
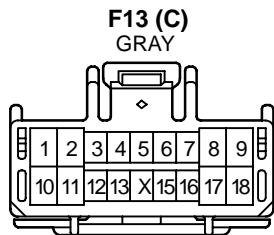
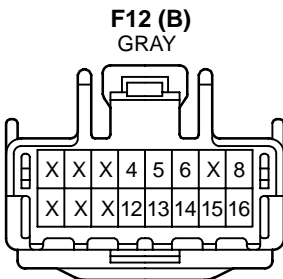
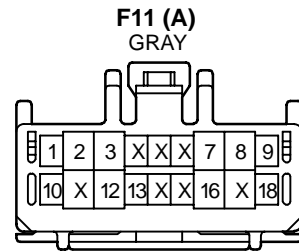
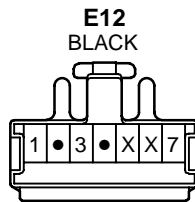
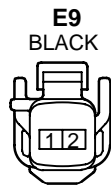
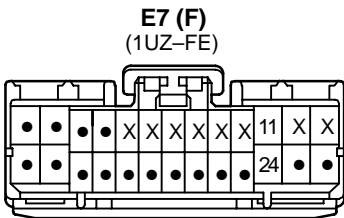
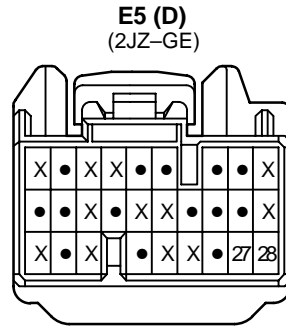
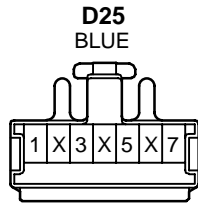
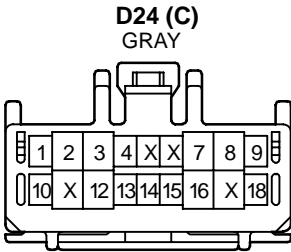
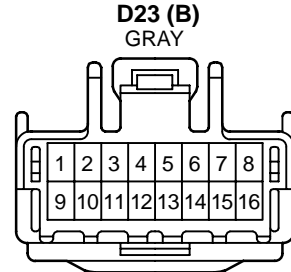
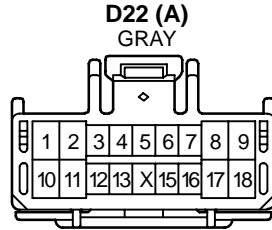
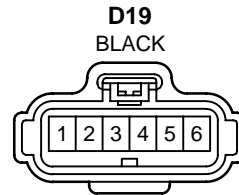
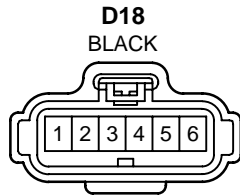
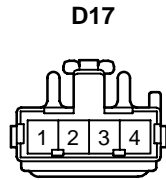
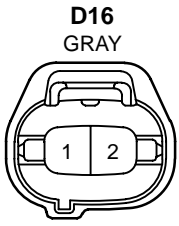

MULTIPLEX COMMUNICATION SYSTEM

I21

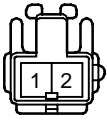

I24

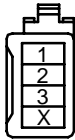

I25

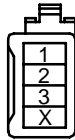

J6

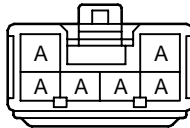

(Hint : See Page 7)

J7
GRAY

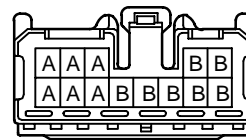

(Hint : See Page 7)

J8
BLACK



(Hint : See Page 7)

J9
(1UZ-FE)

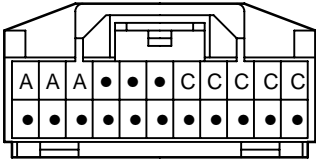

(Hint : See Page 7)

J9
(2JZ-GE)

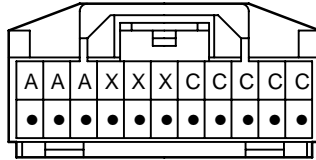

(Hint : See Page 7)

J10
ORANGE

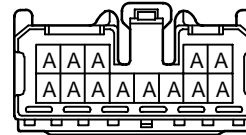

(Hint : See Page 7)

J13

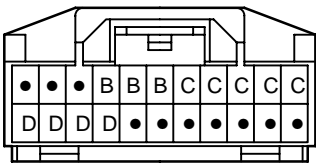

(Hint : See Page 7)

J14

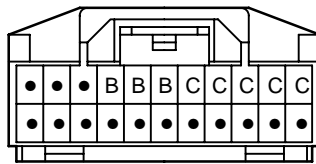

(Hint : See Page 7)

J15

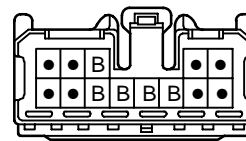

(Hint : See Page 7)

J17

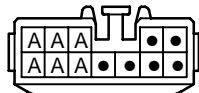

(Hint : See Page 7)

J18
BLUE

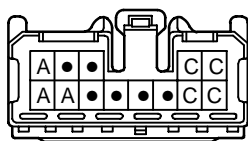

(Hint : See Page 7)

J20

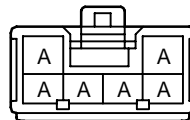

(Hint : See Page 7)

J22

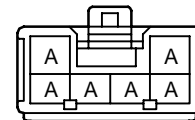

(Hint : See Page 7)

J23

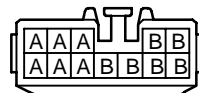

(Hint : See Page 7)

J24

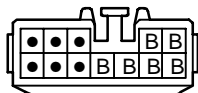

(Hint : See Page 7)

L1



L4

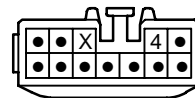

L5
BLACK

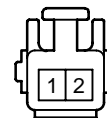

L6

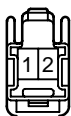

L7
GRAY



L8



M3
BLUE

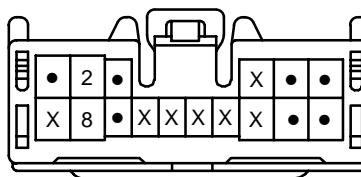

M5

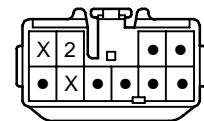

M7
DARK GRAY

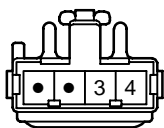

N6
BLUE

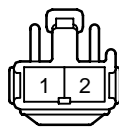

P4



P7

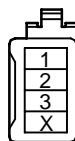

P8

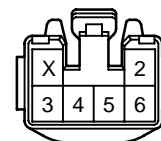

P9

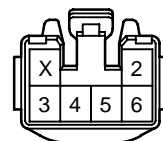

P10

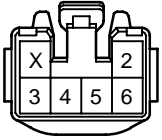

P11

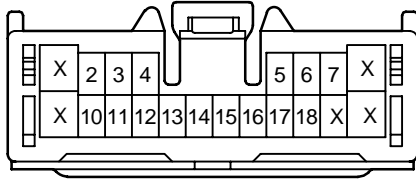

P12



P13



P16
BLACK

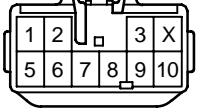

P18 (A)

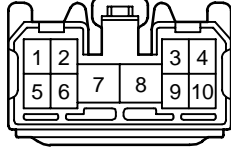

P19 (B)

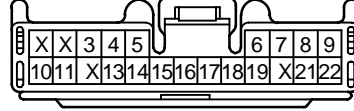

P20
ORANGE

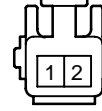

P21

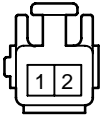

P22

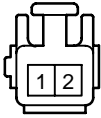

P23

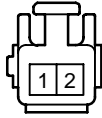

P24

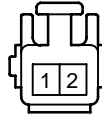

P30
ORANGE

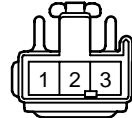

P31

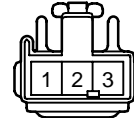

P32

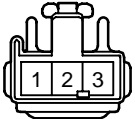

P33



R6
BLACK

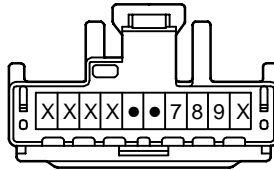

R7

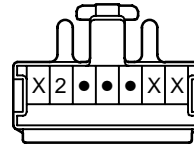

R12

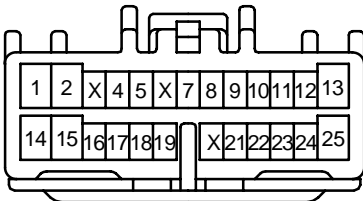

R13

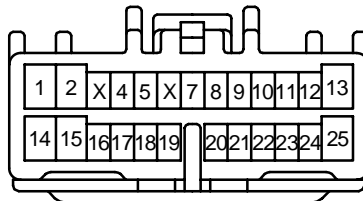

R16 (A)
(w/ Driving Position Memory)

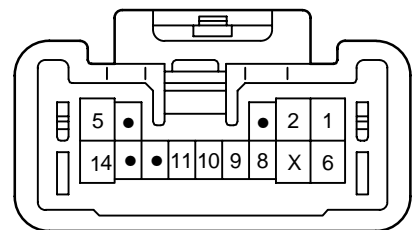

R16 (B)
(w/o Driving Position Memory)



R17 (A)
(w/ Driving Position Memory)

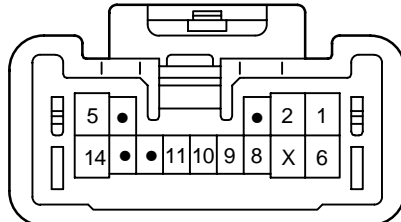

R17 (B)
(w/o Driving Position Memory)

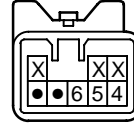

S4

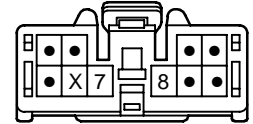

MULTIPLEX COMMUNICATION SYSTEM

S5
BLACK



S6
BLACK



S11
BLUE

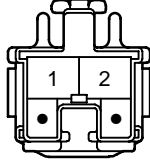

S18
GREEN

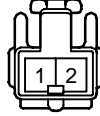

T1
BLACK

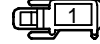

T5
GRAY

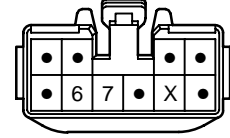

U1

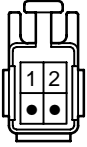

V8



V9

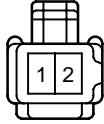

W4
BLACK

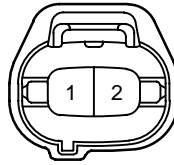

W5

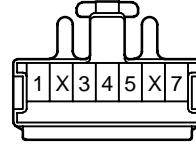

POWER SEAT (DRIVER'S SEAT w/ DRIVING POSITION MEMORY)

FROM POWER SOURCE SYSTEM (SEE PAGE 60)

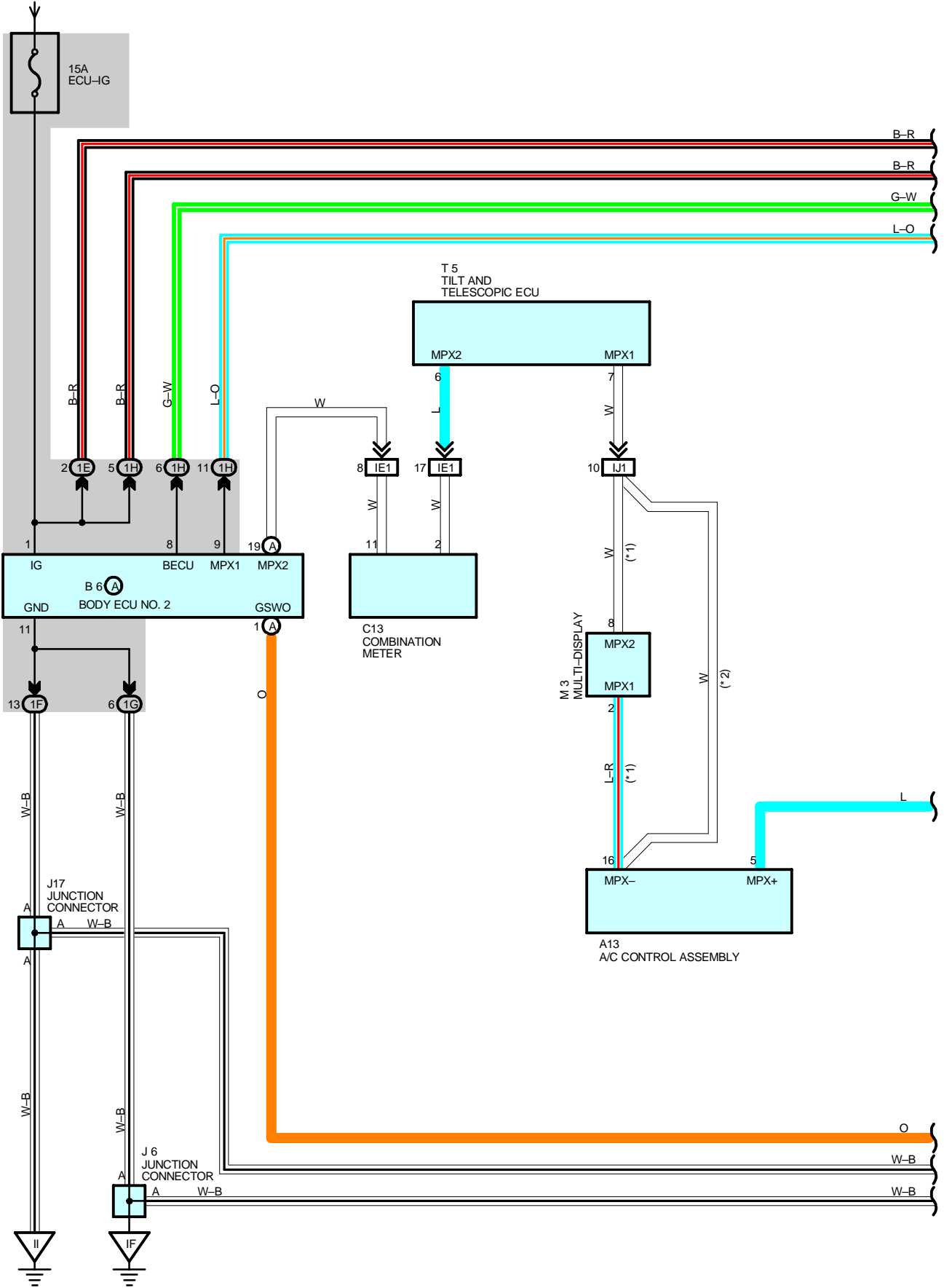

* 1 : W LEXUS NAVIGATION SYSTEM
 * 2 : W/O LEXUS NAVIGATION SYSTEM

* 3 : 1UZ-FE
 * 4 : 2JZ-GE

FROM POWER SOURCE SYSTEM (SEE PAGE 60)

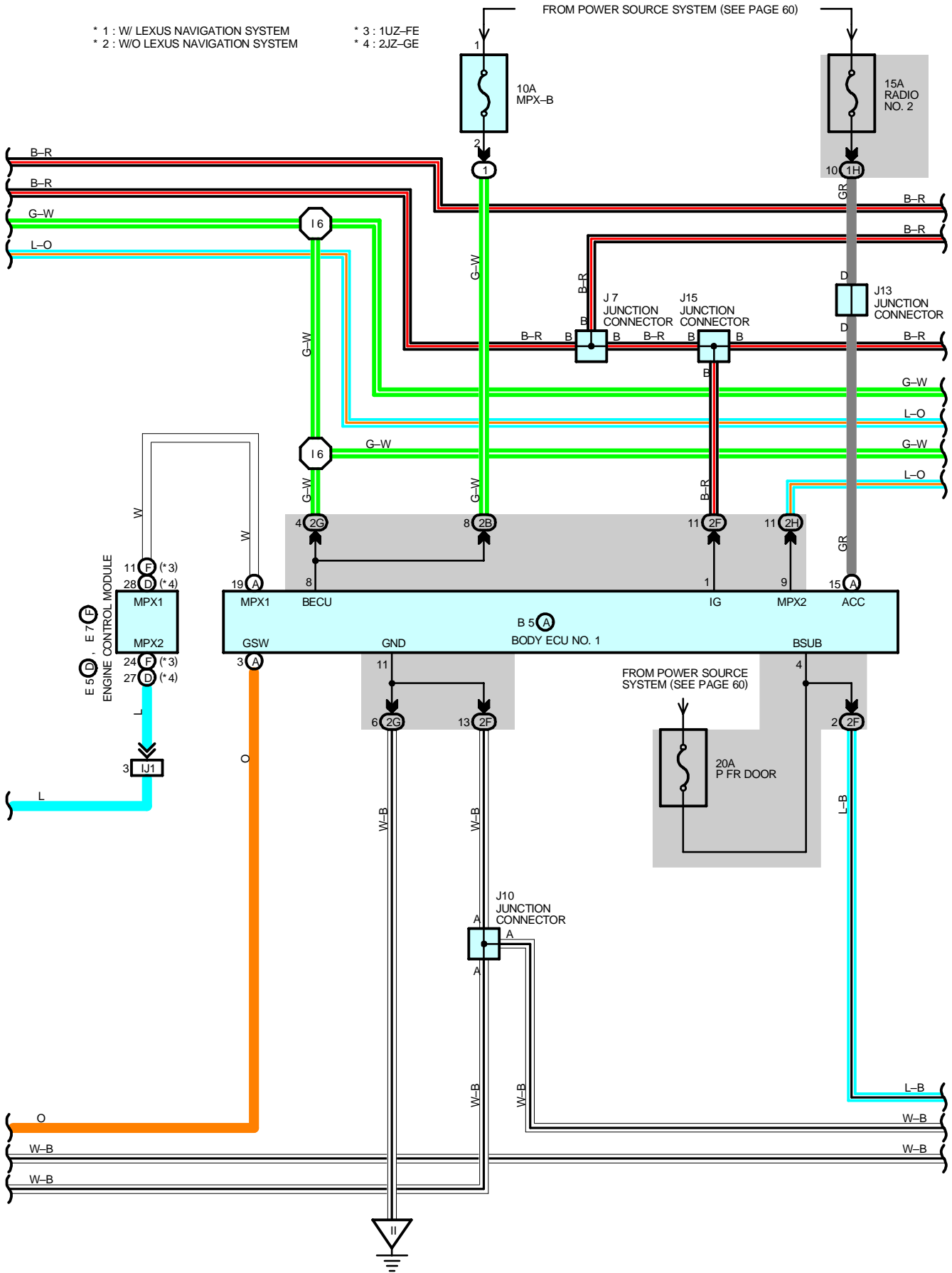

POWER SEAT (DRIVER'S SEAT w/ DRIVING POSITION MEMORY)

FROM POWER SOURCE SYSTEM (SEE PAGE 60)

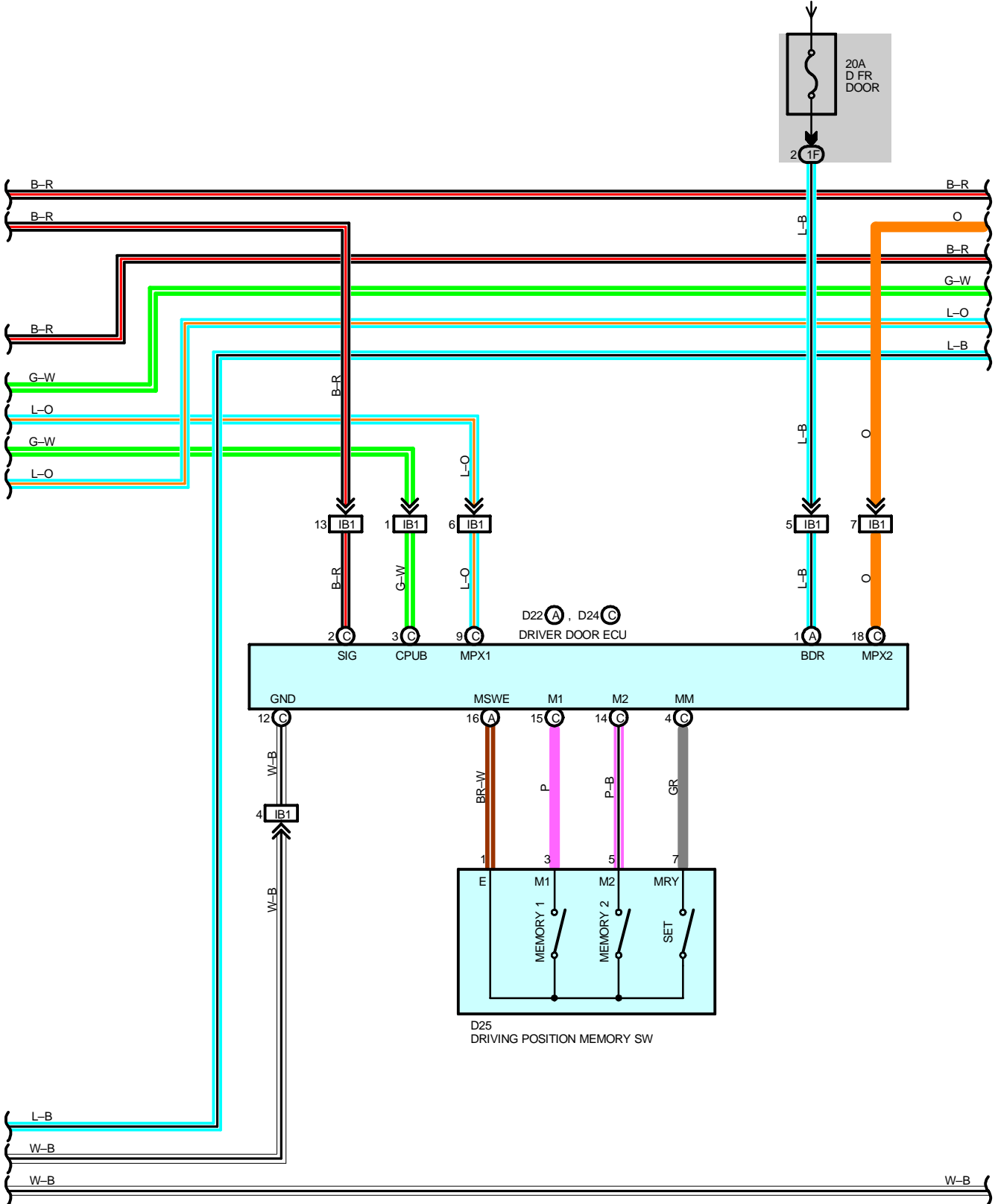

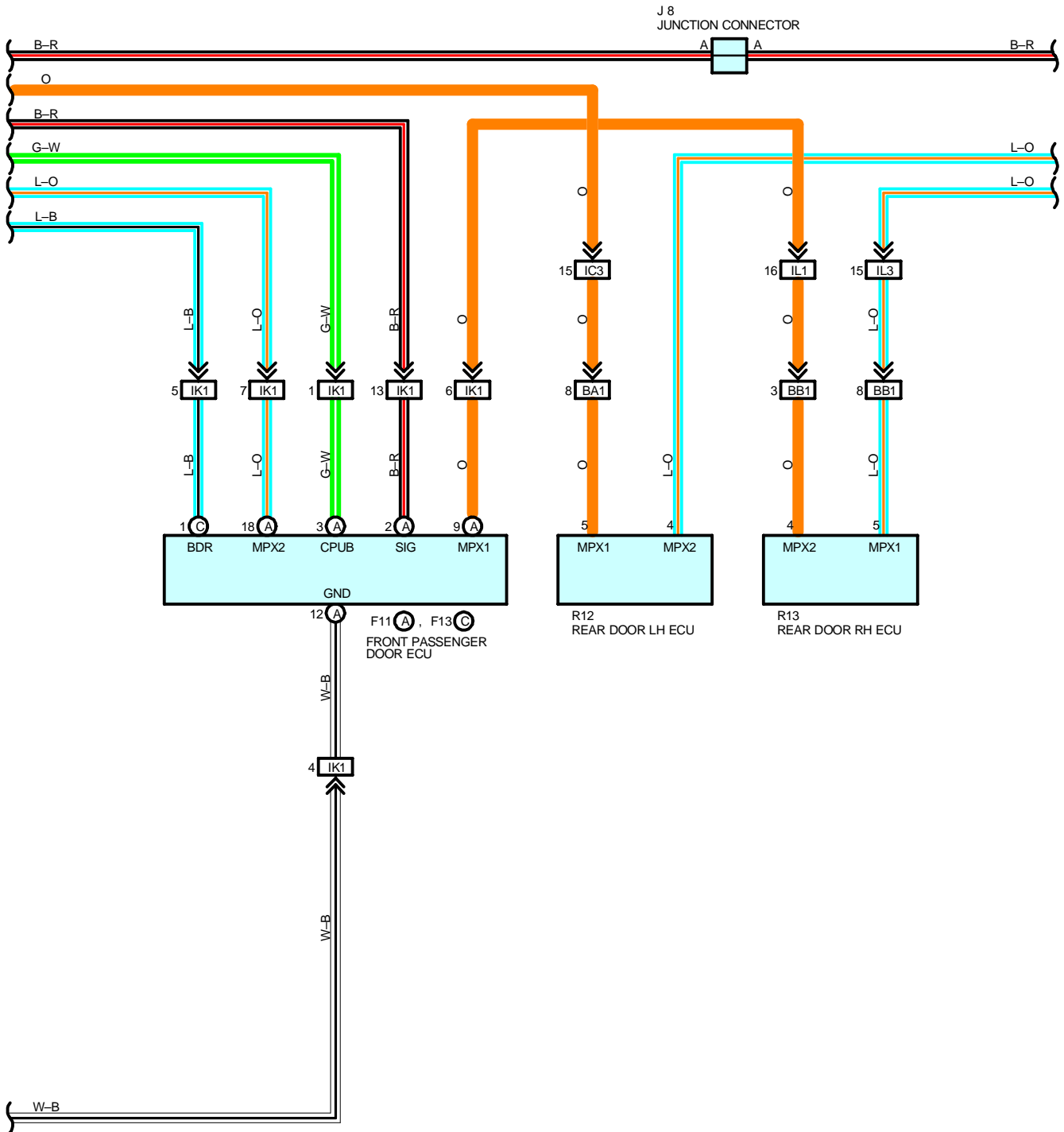

POWER SEAT (DRIVER'S SEAT w/ DRIVING POSITION MEMORY)

FROM POWER SOURCE SYSTEM (SEE PAGE 60)

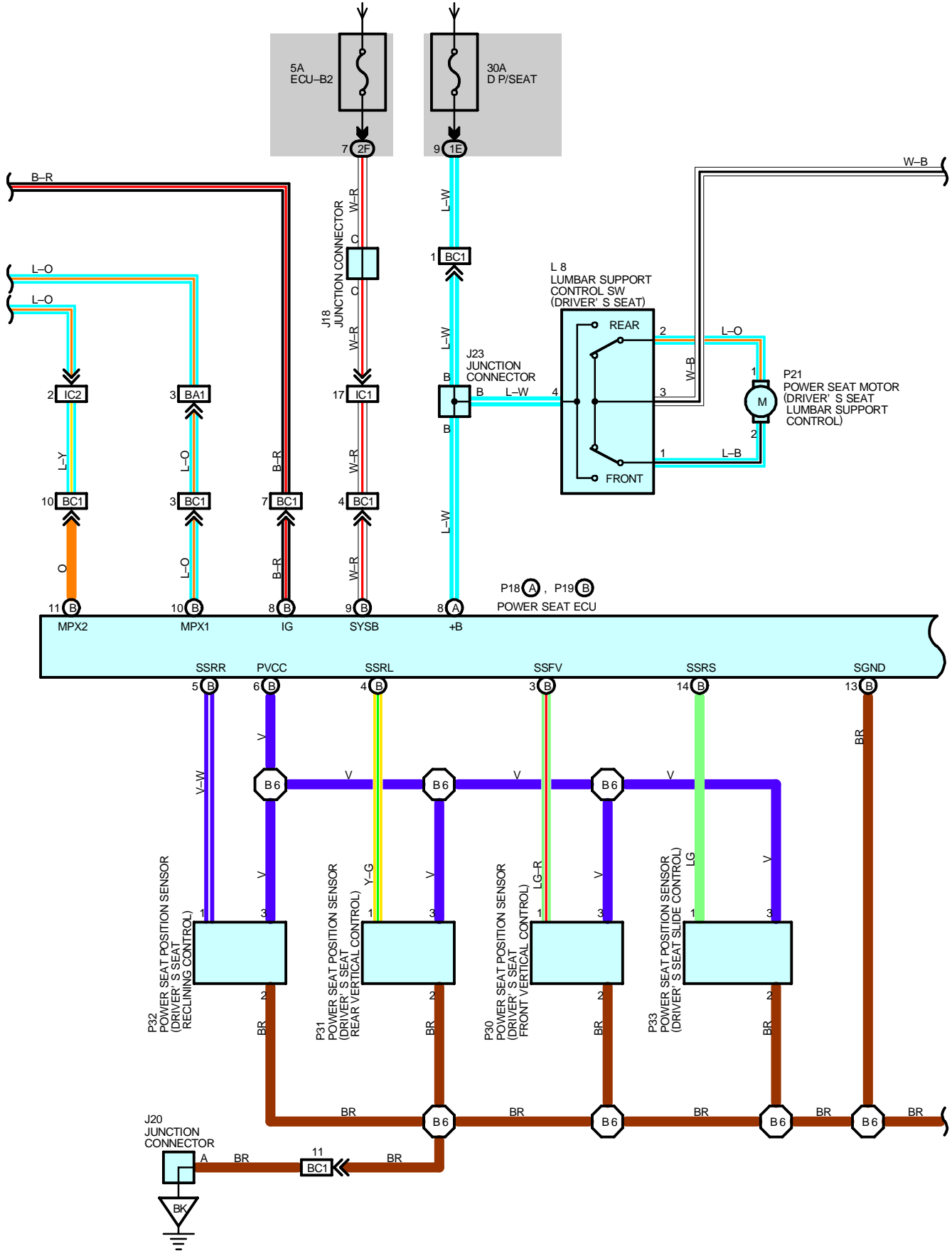

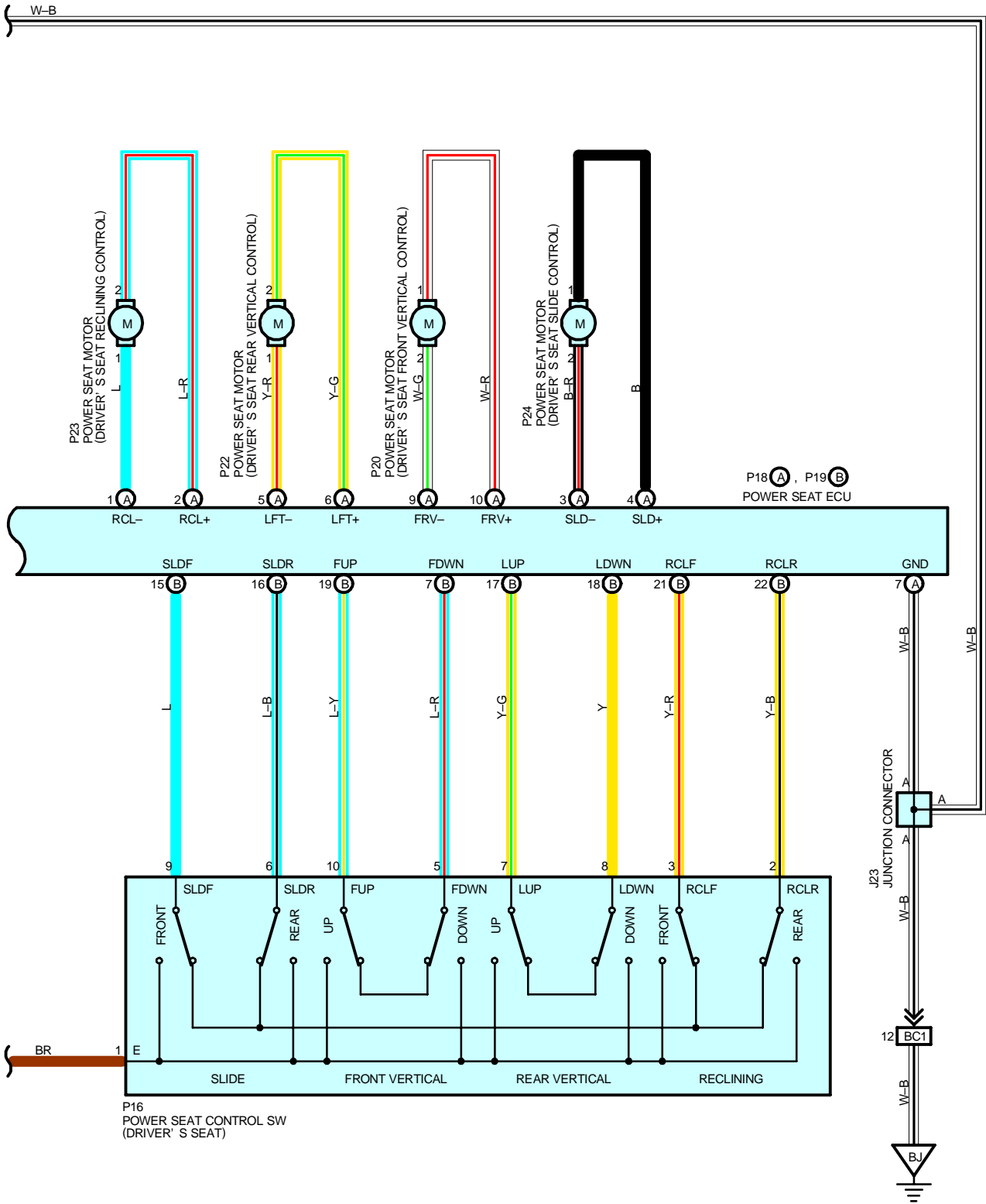

POWER SEAT (DRIVER'S SEAT w/ DRIVING POSITION MEMORY)

SYSTEM OUTLINE

1. MANUAL SLIDE OPERATION

When the slide SW of the power seat control SW is pressed to FRONT position, the signal is input to TERMINAL (B) 15 of the power seat ECU. This activates the power seat ECU to flow the current into TERMINAL (A) 3 of the power seat ECU to TERMINAL 2 of the power seat motor (Slide control) to TERMINAL 1 to TERMINAL (A) 4 of the ECU to GROUND, to move the seat forward while the power seat control SW is kept pressed.

When the slide SW of the power seat control SW is pressed to the REAR position, the signal is input to TERMINAL (B) 16 of the power seat ECU. This activates the ECU to flow the current into TERMINAL (A) 4 of the power seat ECU, TERMINAL 1 of the power seat motor (Slide control) to TERMINAL 2 to TERMINAL (A) 3 of the ECU to GROUND, to move the seat back backward.

At this time, the power seat position sensor (Slide control) detects the seat position and always inputs it to TERMINAL (B) 14 of the power seat ECU.

2. MANUAL RECLINING CONTROL

When the reclining SW of the power seat control SW is pressed forward, the signal is input to TERMINAL (B) 21 of the power seat ECU. This activates the power seat ECU to flow the current into TERMINAL (A) 1 of the power seat ECU to TERMINAL 1 of the power seat motor (Reclining control) to TERMINAL 2 to TERMINAL (A) 2 of the ECU to GROUND, to tilt the seat back forward while the power seat control SW is kept pressed.

When the reclining SW of the power seat control SW is pressed backward, the signal is input to TERMINAL (B) 22 of the power seat ECU. This activates the ECU to flow the current into TERMINAL (A) 2 of the power seat ECU, TERMINAL 2 of the power seat motor (Reclining control) to TERMINAL 1 to TERMINAL (A) 1 of the ECU to GROUND, to tilt the seat backward.

At this time, the power seat position sensor (Reclining control) detects the seat back position and always inputs it to TERMINAL (B) 5 of the power seat ECU.

3. MANUAL FRONT VERTICAL CONTROL

When the front part of the slide SW of the power seat control SW is pushed up, the signal is input to TERMINAL (B) 19 of the power seat ECU. This activates the power seat ECU to flow the current into TERMINAL (A) 10 of the power seat ECU to TERMINAL 1 of the power seat motor (Front vertical control) to TERMINAL 2 to TERMINAL (A) 9 of the ECU to GROUND, to raise the front part of the seat cushion while the power seat control SW is kept pressed.

When the front part of the slide SW of the power seat control SW is pushed down, the signal is input to TERMINAL (B) 7 of the power seat ECU. This activates the power seat ECU to flow the current into TERMINAL (A) 9 of the power seat ECU, TERMINAL 2 of the power seat motor (Front vertical control) to TERMINAL 1 to TERMINAL (A) 10 of the ECU to GROUND, to lower the front part of the seat cushion while the power seat control SW is kept pressed.

At this time, the power seat position sensor (Front vertical control) detects the seat cushion position (Front) and always inputs the signal to TERMINAL (B) 3 of the power seat ECU.

4. MANUAL REAR VERTICAL OPERATION

When the rear part of the slide SW of the power seat control SW is pushed up, the signal is input to TERMINAL (B) 17 of the power seat ECU. This activates the power seat ECU to flow the current into TERMINAL (A) 6 of the power seat ECU to TERMINAL 2 of the power seat motor (Rear vertical control) to TERMINAL 1 to TERMINAL (A) 5 of the ECU to GROUND, to raise the seat while the power seat control SW is kept pressed.

When the rear part of the slide SW of the power seat control SW is pushed down, the signal is input to TERMINAL (B) 18 of the power seat ECU. This activates the ECU to flow the current into TERMINAL (A) 5 of the power seat ECU to TERMINAL 1 of the power seat motor (Rear vertical control) to TERMINAL 2 to TERMINAL (A) 6 of the ECU to GROUND, to lower the seat while the power seat control SW is kept pressed.

At this time, the power seat position sensor (Rear vertical control) detects the seat cushion position (Rear) and always inputs the signal to TERMINAL (B) 4 of the power seat ECU.

5. MANUAL LUMBAR SUPPORT OPERATION

When the lumbar support control SW is pressed forward, the current flows from the D P/SEAT fuse into TERMINAL 4 to TERMINAL 1 of the lumbar support control SW to TERMINAL 2 of the power seat motor (Lumbar support control) to TERMINAL 1 to TERMINAL 2 of the SW to TERMINAL 3 to GROUND, to move the lumbar support forward.

When the SW is pressed backward, the current from the D P/SEAT fuse flows into TERMINAL 4 to TERMINAL 2 of the lumbar support control SW to TERMINAL 1 of the power seat motor (Lumbar support control) to TERMINAL 2 to TERMINAL 1 of the SW to TERMINAL 3 to GROUND, to move the lumbar support backward.

6. DRIVING POSITION MEMORY FUNCTION

Each position sensor in the seat detects the number of rotations of the relevant motor (Seat movement amount) and inputs it to the ECU. This makes it possible to store and recall the seat position by operating the position memory SW. The driving seat position is stored and recalled through communication control of the body ECU and door ECU etc.

SERVICE HINTS

P18 (A), P19 (B) POWER SEAT ECU

- (B) 9-GROUND : Always approx. **12** volts
- (A) 8-GROUND : Always approx. **12** volts
- (A) 7-GROUND : Always continuity
- (B)13-GROUND : Always continuity
- (B) 8-GROUND : Approx. **12** volts with ignition SW at **ON** or **ST** position
- (A) 1-GROUND : Approx. **12** volts with driver's seat at front reclining operation
- (A) 2-GROUND : Approx. **12** volts with driver's seat at rear reclining operation
- (A)10-GROUND : Approx. **12** volts with driver's seat at front vertical up operation
- (A) 9-GROUND : Approx. **12** volts with driver's seat at front vertical down operation
- (A) 6-GROUND : Approx. **12** volts with driver's seat at rear vertical up operation
- (A) 5-GROUND : Approx. **12** volts with driver's seat at rear vertical down operation
- (A) 3-GROUND : Approx. **12** volts with driver's seat at front slide operation
- (A) 4-GROUND : Approx. **12** volts with driver's seat at rear slide operation

P16 POWER SEAT CONTROL SW (DRIVER'S SEAT)

- 3-1 : Closed with Driver's seat at front reclining operation
- 2-1 : Closed with Driver's seat at rear reclining operation
- 10-1 : Closed with Driver's seat at front vertical up operation
- 5-1 : Closed with Driver's seat at front vertical down operation
- 7-1 : Closed with Driver's seat at rear vertical up operation
- 8-1 : Closed with Driver's seat at rear vertical down operation
- 9-1 : Closed with Driver's seat at front slide operation
- 6-1 : Closed with Driver's seat at rear slide operation

L8 LUMBAR SUPPORT CONTROL SW (DRIVER'S SEAT)

- 4-GROUND : Always approx. **12** volts
- 3-GROUND : Always continuity

○ : PARTS LOCATION

Code	See Page	Code	See Page	Code	See Page
A13	40	J8	41	P20	44
B5	A 40	J10	41	P21	44
B6	A 40	J13	41	P22	44
C13	40	J15	41	P23	44
D22	A 42	J17	41	P24	44
D24	C 42	J18	41	P30	44
D25	42	J20	42	P31	44
E5	D 38 (2JZ-GE)	J23	44	P32	44
E7	F 36 (1UZ-FE)	L8	44	P33	44
F11	A 42	M3	41	R12	43
F13	C 42	P16	44	R13	43
J6	41	P18	A 44	T5	41
J7	41	P19	B 44		

○ : RELAY BLOCKS

Code	See Page	Relay Blocks (Relay Block Location)
1	22	Engine Room No.1 R/B (Engine Compartment Right)

POWER SEAT (DRIVER'S SEAT w/ DRIVING POSITION MEMORY)

: JUNCTION BLOCK AND WIRE HARNESS CONNECTOR

Code	See Page	Junction Block and Wire Harness (Connector Location)
1E	26	Floor No.2 Wire and Driver Side J/B (Left Kick Panel)
1F	26	Cowl Wire and Driver Side J/B (Left Kick Panel)
1G	27	
1H		
2B	28	
2F	28	Cowl Wire and Passenger Side J/B (Right Kick Panel)
2G	29	
2H		

: CONNECTOR JOINING WIRE HARNESS AND WIRE HARNESS

Code	See Page	Joining Wire Harness and Wire Harness (Connector Location)
IB1	50	Front Door LH Wire and Cowl Wire (Left Kick Panel)
IC1	50	Floor No.2 Wire and Cowl Wire (Left Kick Panel)
IC2		
IC3		
IE1	50	Instrument Panel Wire and Cowl Wire (Left Side of the Steering Column)
IJ1	52	Instrument Panel Wire and Cowl Wire (Left Side of the Blower Unit)
IK1	52	Front Door RH Wire and Cowl Wire (Right Kick Panel)
IL1	52	Floor No.1 Wire and Cowl Wire (Right Kick Panel)
IL3		
BA1	54	Rear Door LH Wire and Floor No.2 Wire (Under the Center Pillar LH)
BB1	54	Rear Door RH Wire and Floor No.1 Wire (Under the Center Pillar RH)
BC1	56	Floor No.2 Wire and Front Seat LH Wire (Under the Driver's Seat)

: GROUND POINTS

Code	See Page	Ground Points Location
IF	50	Left Kick Panel
II	50	Right Side of the Cowl Panel
BJ	54	Rear Floor Partition Panel LH
BK	54	Quarter Panel LH

: SPLICE POINTS

Code	See Page	Wire Harness with Splice Points	Code	See Page	Wire Harness with Splice Points
I6	52	Cowl Wire	B6	56	Front Seat LH Wire

A13

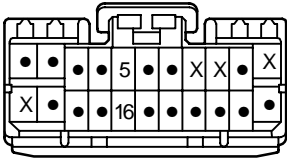

B5 (A)

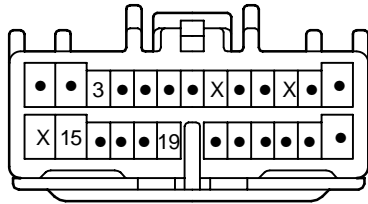

B6 (A)

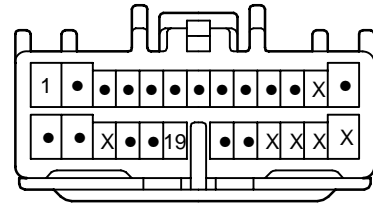

C13

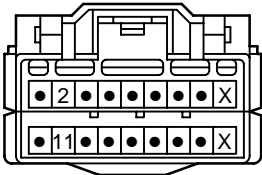

D22 (A)
GRAY

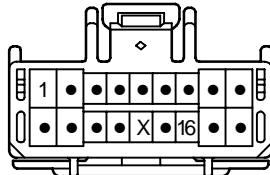

D24 (C)
GRAY

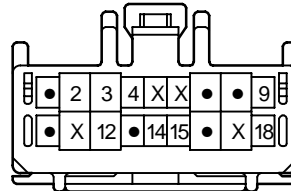

D25
BLUE

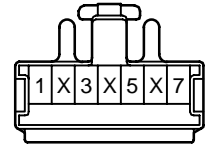

E5 (D)
(2JZ-GE)

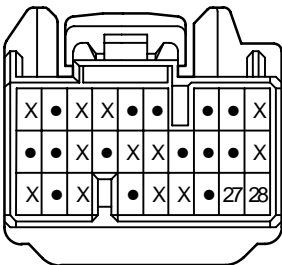

E7 (F)
(1UZ-FE)

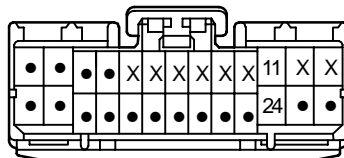

F11 (A)
GRAY

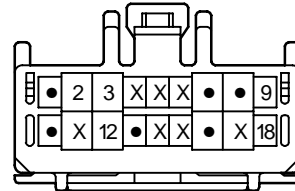

F13 (C)
GRAY

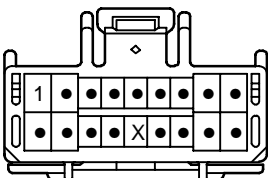

J6

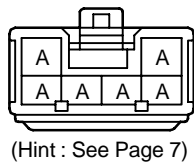

(Hint : See Page 7)

J7
GRAY

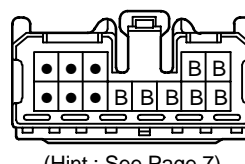

(Hint : See Page 7)

J8
BLACK



(Hint : See Page 7)

J10
ORANGE

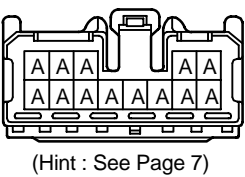

(Hint : See Page 7)

J13

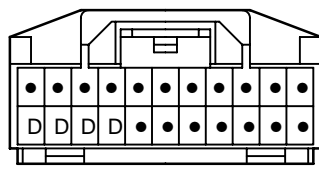

(Hint : See Page 7)

J15

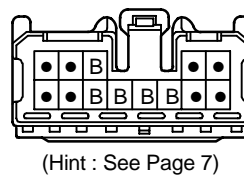

(Hint : See Page 7)

J17

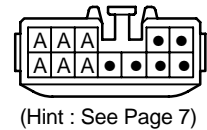

(Hint : See Page 7)

J18
BLUE

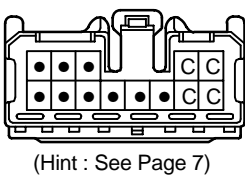

(Hint : See Page 7)

J20

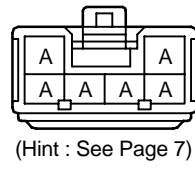

(Hint : See Page 7)

J23

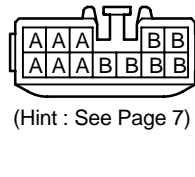

(Hint : See Page 7)

L8



POWER SEAT (DRIVER'S SEAT w/ DRIVING POSITION MEMORY)

M3
BLUE

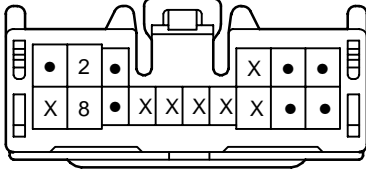

P16
BLACK

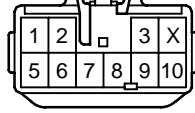

P18 (A)

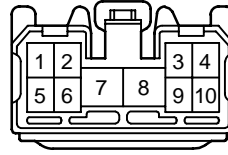

P19 (B)

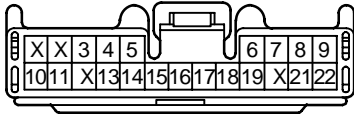

P20
ORANGE

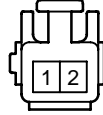

P21

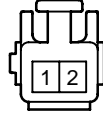

P22

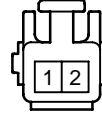

P23

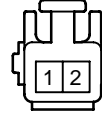

P24

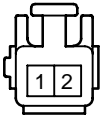

P30
ORANGE

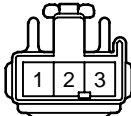

P31

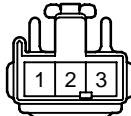

P32

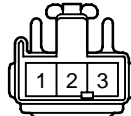

P33

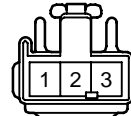

R12

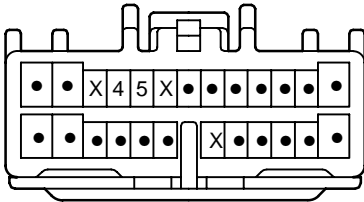

R13

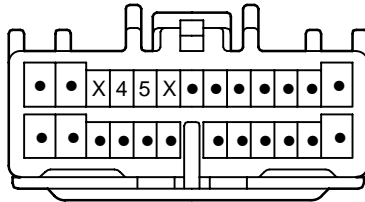

T5
GRAY

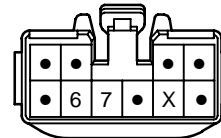

POWER SEAT (DRIVER'S SEAT w/o DRIVING POSITION MEMORY)

FROM POWER SOURCE SYSTEM (SEE PAGE 60)

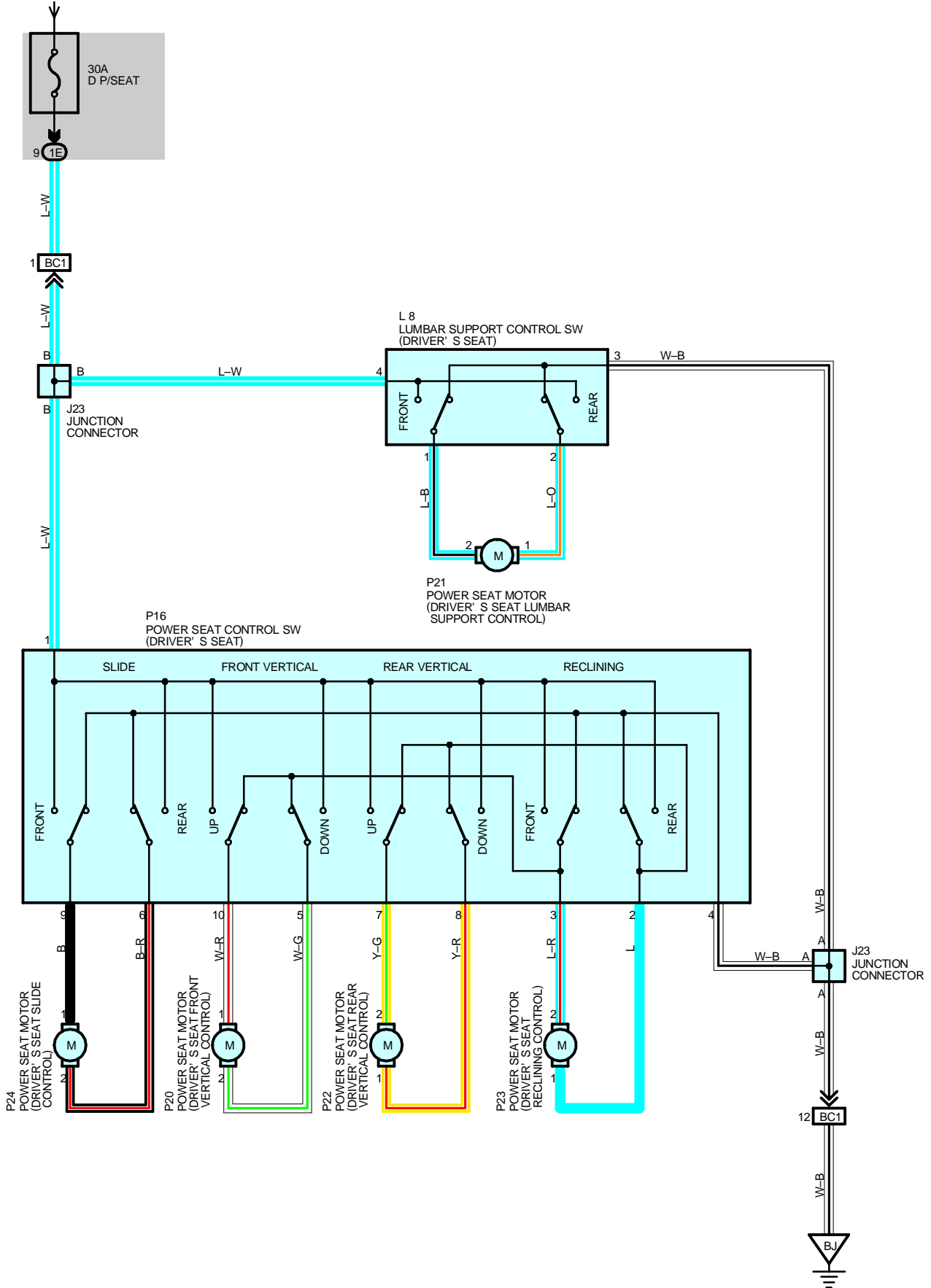

SERVICE HINTS

P16 POWER SEAT CONTROL SW (DRIVER'S SEAT)

1-GROUND : Always approx. 12 volts

4-GROUND : Always continuity

L8 LUMBAR SUPPORT CONTROL SW (DRIVER'S SEAT)

4-GROUND : Always approx. 12 volts

3-GROUND : Always continuity

○ : PARTS LOCATION

Code	See Page	Code	See Page	Code	See Page
J23	44	P20	44	P23	44
L8	44	P21	44	P24	44
P16	44	P22	44		

○ : JUNCTION BLOCK AND WIRE HARNESS CONNECTOR

Code	See Page	Junction Block and Wire Harness (Connector Location)
1E	26	Floor No.2 Wire and Driver Side J/B (Left Kick Panel)

□ : CONNECTOR JOINING WIRE HARNESS AND WIRE HARNESS

Code	See Page	Joining Wire Harness and Wire Harness (Connector Location)
BC1	56	Floor No.2 Wire and Front Seat LH Wire (Under the Driver's Seat)

▽ : GROUND POINTS

Code	See Page	Ground Points Location
BJ	54	Rear Floor Partition Panel LH

J23

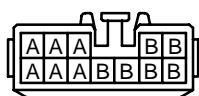

(Hint : See Page 7)

L8

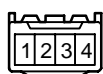

P16
BLACK

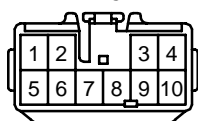

P20
ORANGE

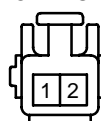

P21

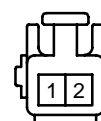

P22
BLUE

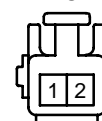

P23

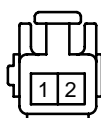

P24

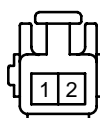

POWER SEAT (FRONT PASSENGER'S SEAT)

FROM POWER SOURCE SYSTEM (SEE PAGE 60)

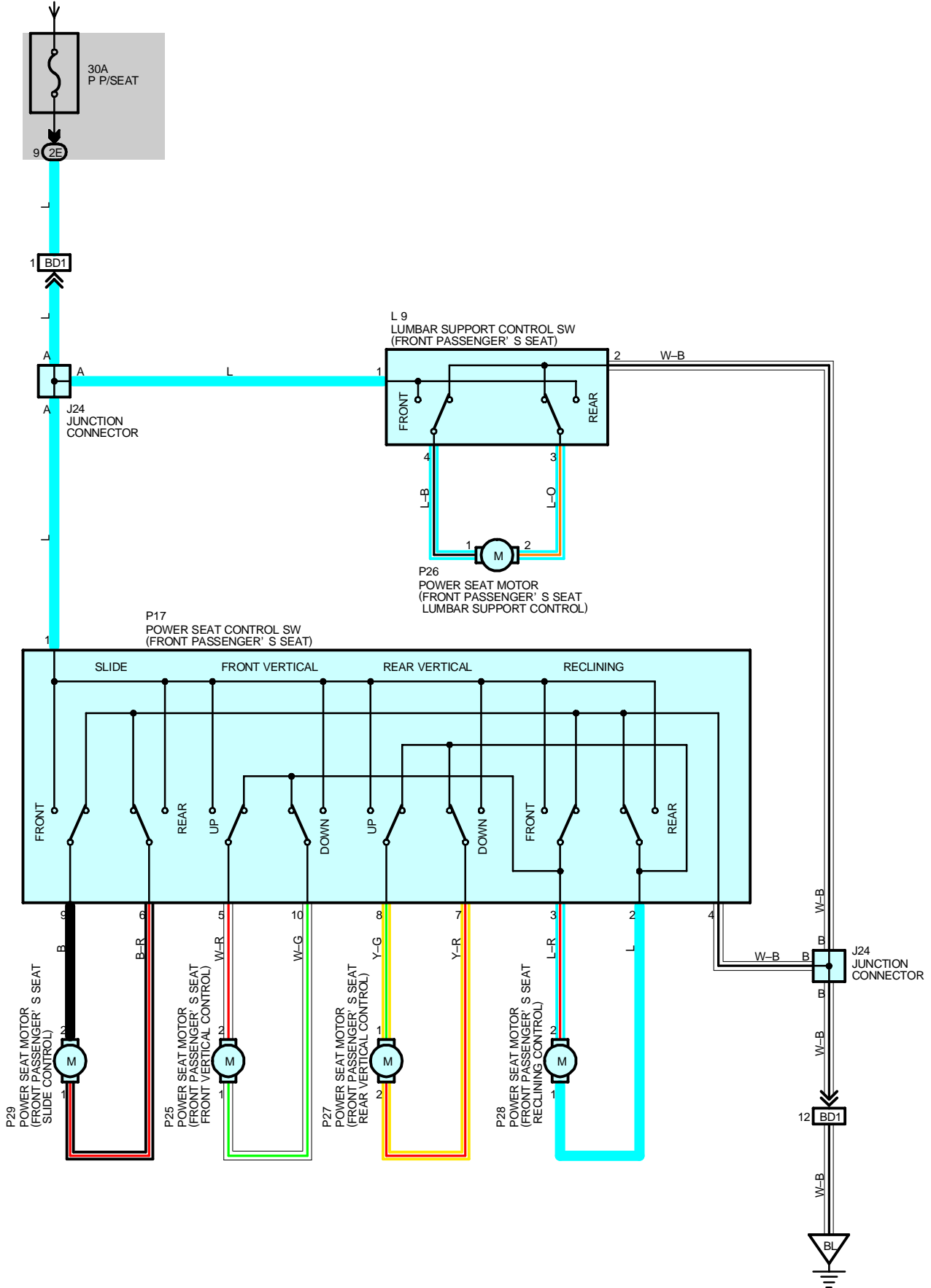

SERVICE HINTS

P17 POWER SEAT CONTROL SW (FRONT PASSENGER'S SEAT)

1-GROUND : Always approx. 12 volts

4-GROUND : Always continuity

L9 LUMBAR SUPPORT CONTROL SW (FRONT PASSENGER'S SEAT)

1-GROUND : Always approx. 12 volts

2-GROUND : Always continuity

○ : PARTS LOCATION

Code	See Page	Code	See Page	Code	See Page
J24	44	P25	44	P28	44
L9	44	P26	44	P29	44
P17	44	P27	44		

○ : JUNCTION BLOCK AND WIRE HARNESS CONNECTOR

Code	See Page	Junction Block and Wire Harness (Connector Location)
2E	28	Floor No.1 Wire and Passenger Side J/B (Right Kick Panel)

□ : CONNECTOR JOINING WIRE HARNESS AND WIRE HARNESS

Code	See Page	Joining Wire Harness and Wire Harness (Connector Location)
BD1	56	Floor No.1 Wire and Front Seat RH Wire (Under the Front Passenger's Seat)

▽ : GROUND POINTS

Code	See Page	Ground Points Location
BL	54	Rear Floor Partition Panel RH

J24

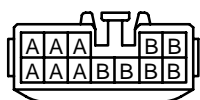

(Hint : See Page 7)

L9

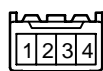

P17
BLACK

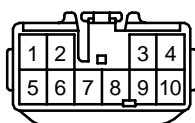

P25
BLUE

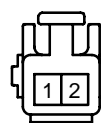

P26

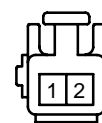

P27

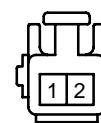

P28

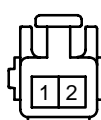

P29



POWER SOURCE

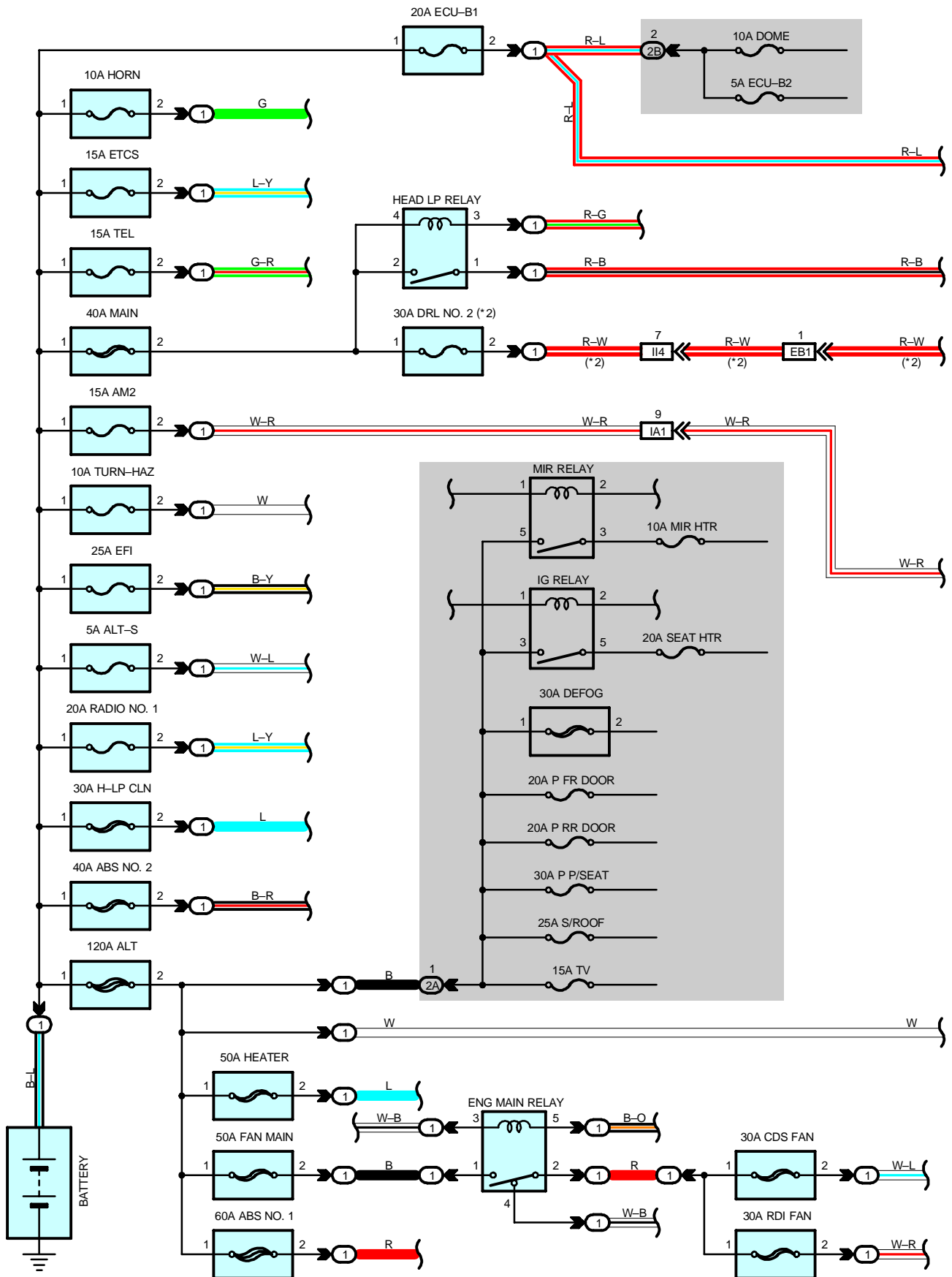

* 1 : W/O DAYTIME RUNNING LIGHT
 * 2 : W/ DAYTIME RUNNING LIGHT

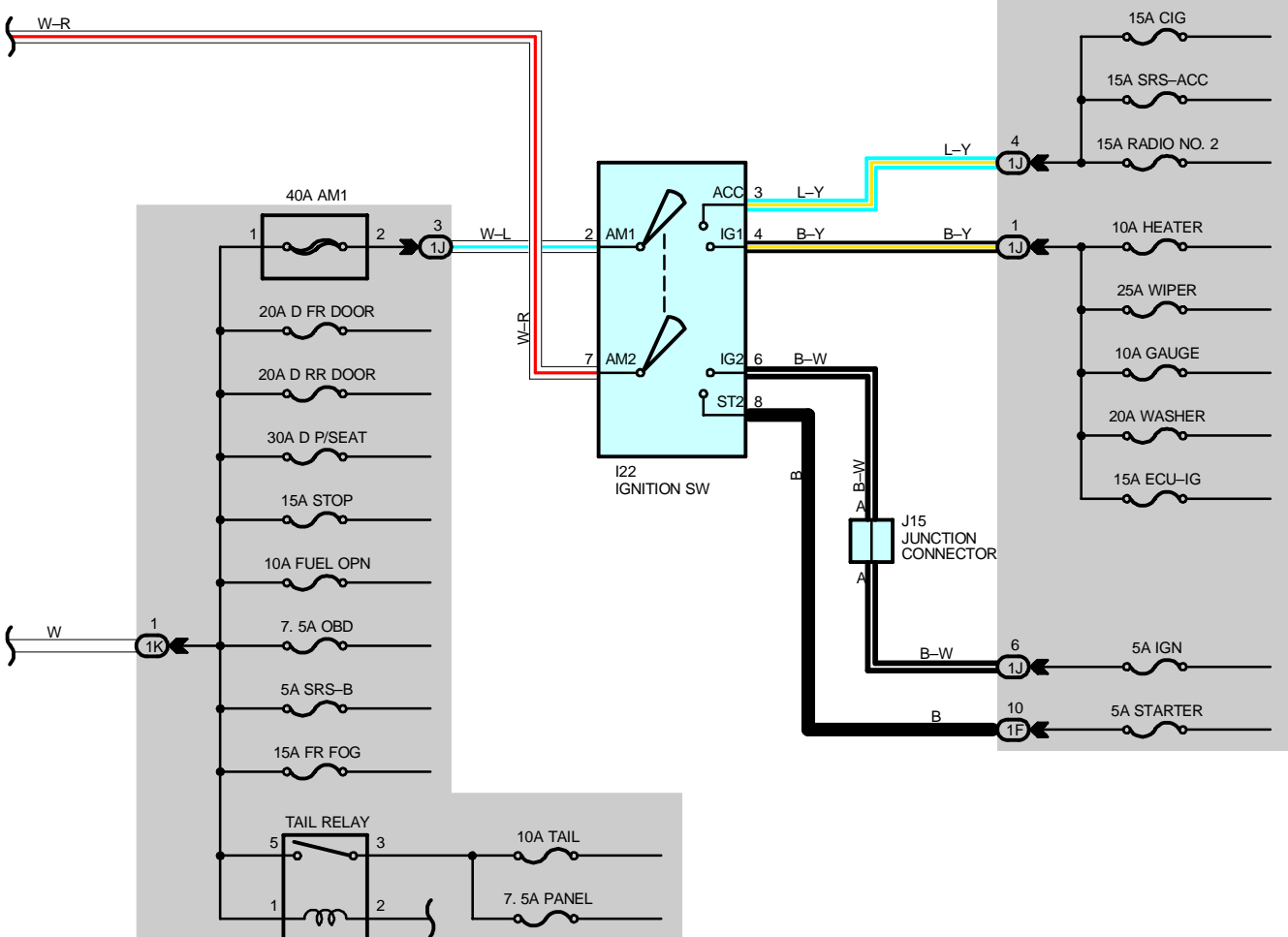
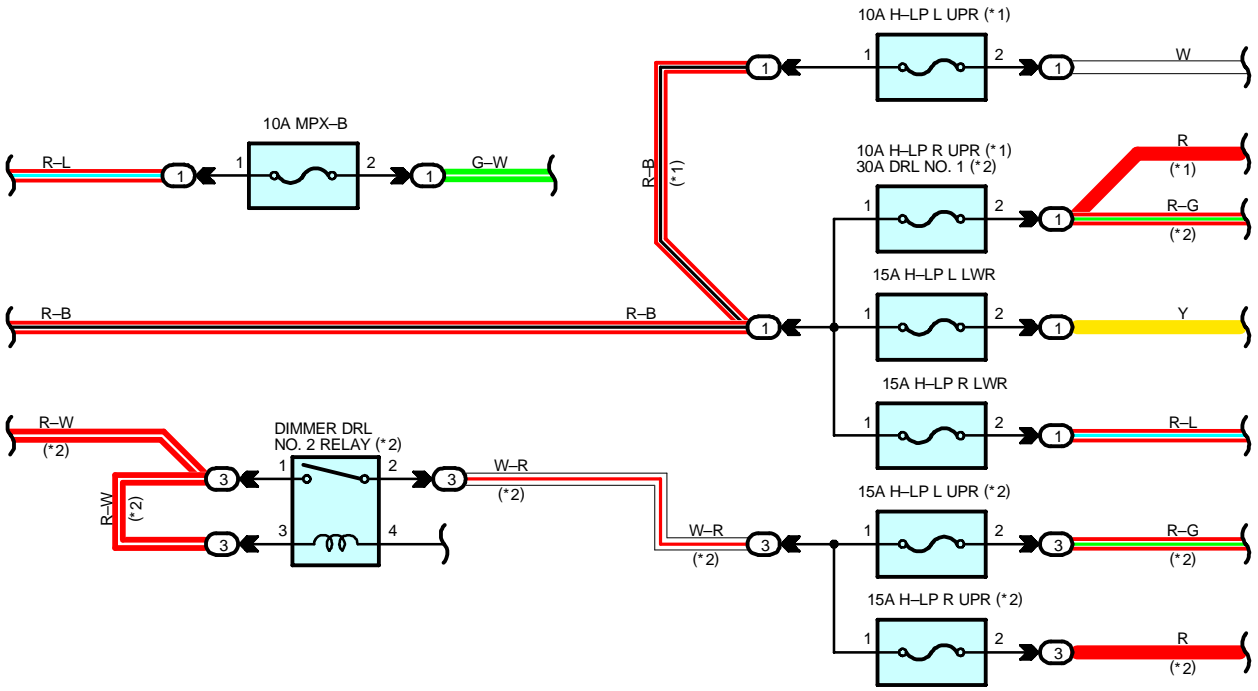

POWER SOURCE

SERVICE HINTS

HEAD LP RELAY (w/o DAYTIME RUNNING LIGHT)

2-1 : Closed with light control SW at **HEAD** position or dimmer SW at **FLASH** position

HEAD LP RELAY (w/ DAYTIME RUNNING LIGHT)

2-1 : Closed with light control SW at **HEAD** position or dimmer SW at **FLASH** position
 Closed with engine running and parking brake released (Parking brake SW off)

TAIL RELAY

5-3 : Closed with light control SW at **TAIL** or **HEAD** position

ENG MAIN RELAY

1-2 : Closed with ignition SW at **ON** or **ST** position

I22 IGNITION SW

2-3 : Closed with ignition key at **ACC** or **ON** position

2-4 : Closed with ignition key at **ON** or **ST** position

7-6 : Closed with ignition key at **ON** or **ST** position

7-8 : Closed with ignition key at **ST** position

○ : PARTS LOCATION

Code	See Page	Code	See Page	Code	See Page
I22	41	J15	41		

○ : RELAY BLOCKS

Code	See Page	Relay Blocks (Relay Block Location)
1	22	Engine Room No.1 R/B (Engine Compartment Right)
3	24	Engine Room No.3 R/B (Engine Compartment Left)

○ : JUNCTION BLOCK AND WIRE HARNESS CONNECTOR

Code	See Page	Junction Block and Wire Harness (Connector Location)
1F	26	Cowl Wire and Driver Side J/B (Left Kick Panel)
1J	27	
1K	26	Engine Room Main Wire and Driver Side J/B (Left Kick Panel)
2A	28	Engine Room Main Wire and Passenger Side J/B (Right Kick Panel)
2B		

□ : CONNECTOR JOINING WIRE HARNESS AND WIRE HARNESS

Code	See Page	Joining Wire Harness and Wire Harness (Connector Location)
EB1	46 (1UZ-FE)	Cowl Wire and Relay Block Wire (Inside of the Engine Room No.3 R/B)
	48 (2JZ-GE)	
IA1	50	Engine Room Main Wire and Cowl Wire (Near the Driver Side J/B)
II4	52	Engine Room Main Wire and Cowl Wire (Near the Passenger Side R/B)

I22

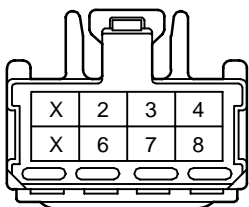

J15

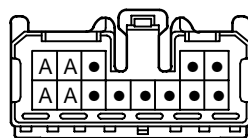

(Hint : See Page 7)

POWER TILT AND POWER TELESCOPIC

FROM POWER SOURCE SYSTEM (SEE PAGE 60)

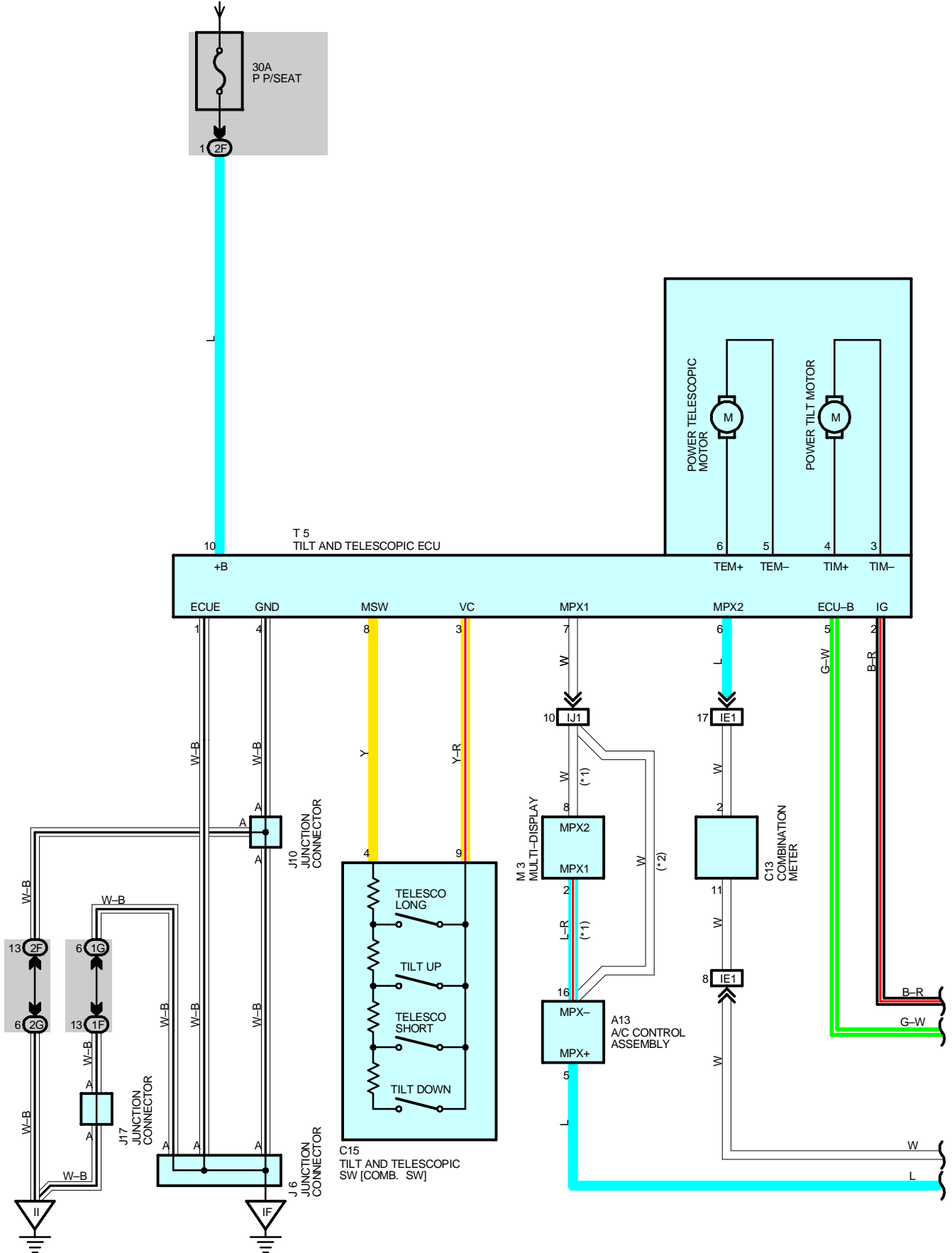

FROM POWER SOURCE SYSTEM (SEE PAGE 60)

- * 1 : W/ LEXUS NAVIGATION SYSTEM
- * 2 : W/O LEXUS NAVIGATION SYSTEM
- * 3 : 1UZ-FE
- * 4 : 2JZ-GE

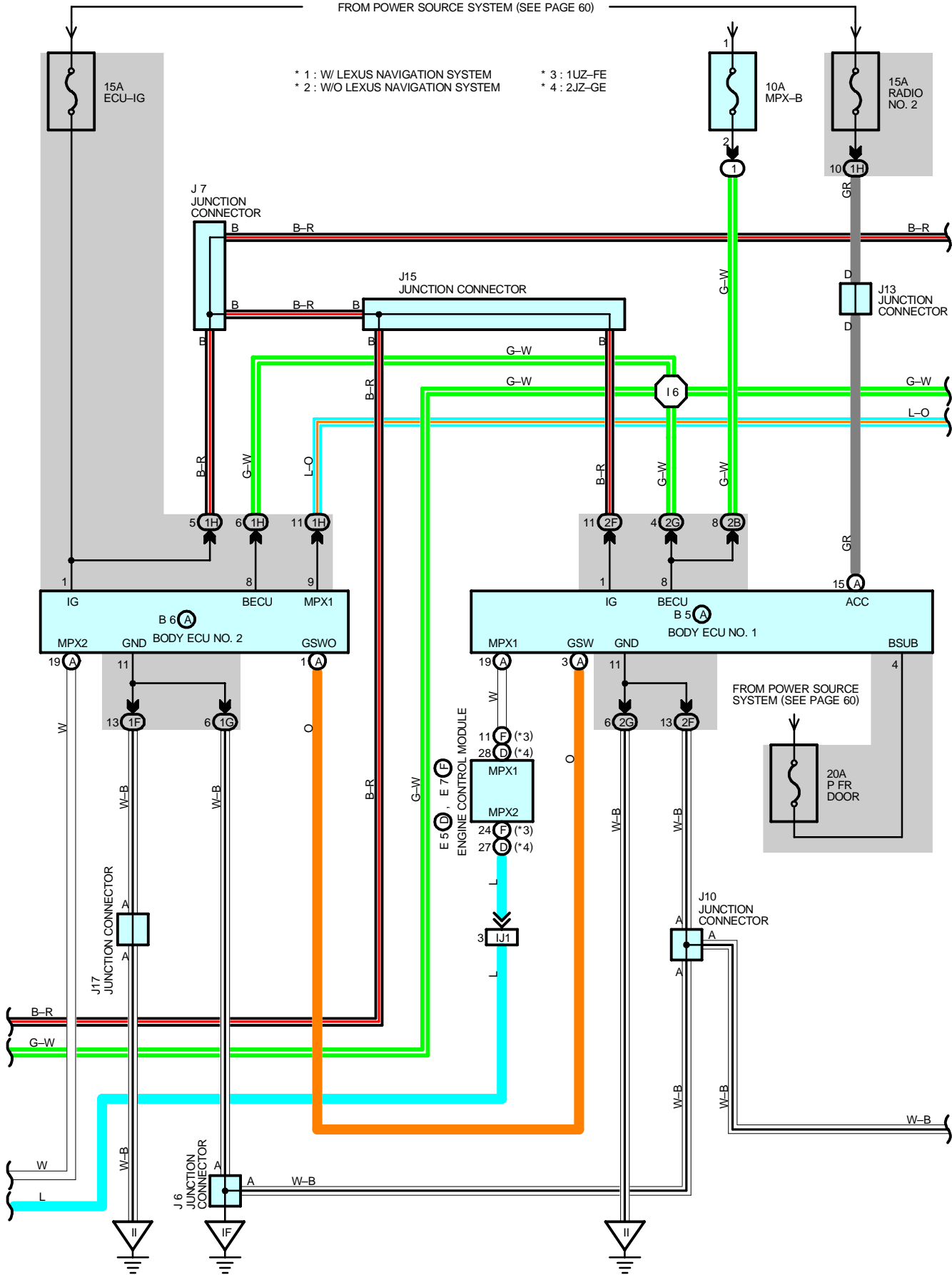

POWER TILT AND POWER TELESCOPIC

FROM POWER SOURCE SYSTEM (SEE PAGE 60)

* 5 : W/ DRIVING POSITION MEMORY

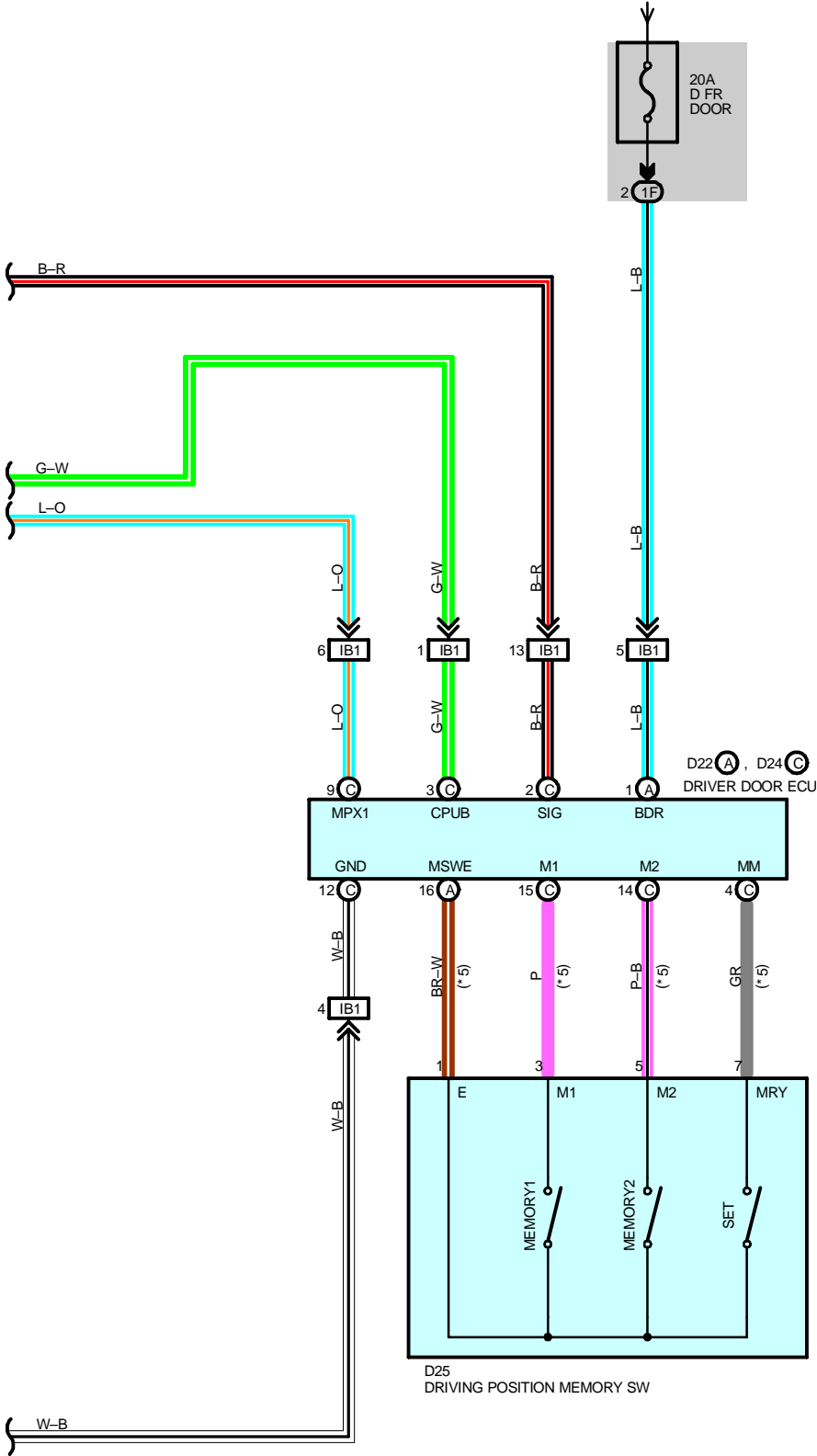

SYSTEM OUTLINE

This system provides the automatic tilt and telescopic mechanisms using the motor drive and ECU control, allowing variable steering movement in the back and forth, and vertical directions. This makes it possible to set the steering to the desired steering position and move the steering to a position where the driver can easily get off the vehicle, allowing easier seating. Additionally, by linking the power seat and remote control mirror, an optimal driving position corresponding to the driver's needs can be stored into the memory.

1. AUTO RETURN OPERATION

When the ignition key is inserted into the key cylinder (The unlock warning SW is on), the signal is input to the tilt and telescopic ECU through communication control of the body ECU and door ECU etc. This activates the ECU to automatically return the steering to the position set before the ignition key has been removed.

2. AUTO AWAY OPERATION

When the ignition key is turned from ON to OFF and removed from the key cylinder (The unlock warning SW is off), the signal is input to the tilt and telescopic ECU through communication control of the body ECU and door ECU etc. This activates the ECU to automatically move the steering to the top tilt step position and maximum telescopic retract position.

3. MANUAL TILT OPERATION

When the ignition key is inserted into the key cylinder, the tilt and telescopic can be adjusted.

Tilt operation

When the tilt and telescopic SW is pressed to TILT DOWN position, the current flows from TERMINAL 3 of the tilt and telescopic ECU into TERMINAL 9 of the tilt and telescopic SW to TERMINAL 4 to TERMINAL 8 of the ECU, and the signal is input to the ECU. This activates the ECU and starts the tilt control motor to lower the steering while the SW is kept pressed to TILT DOWN position.

When the tilt and telescopic SW is pressed to TILT UP position, the current flows from TERMINAL 3 of the tilt and telescopic ECU into TERMINAL 9 of the tilt and telescopic SW to TERMINAL 4 to TERMINAL 8 of the ECU, and the signal is input to the ECU. This activates the ECU and starts the tilt control motor to raise the steering while the SW is kept pressed to TILT UP position.

Telescopic operation

When the tilt and telescopic SW is pressed to TELESCO LONG position, the current flows from TERMINAL 3 of the tilt and telescopic ECU into TERMINAL 9 of the tilt and telescopic SW to TERMINAL 4 to TERMINAL 8 of the ECU, and the signal is input to the ECU. This activates the ECU and starts the telescopic control motor to extend the telescopic while the SW is kept pressed to TELESCO LONG position.

When the tilt and telescopic SW is pressed to TELESCO SHORT side, the current flows from TERMINAL 3 of the tilt and telescopic ECU into TERMINAL 9 of the tilt and telescopic SW to TERMINAL 4 to TERMINAL 8 of the ECU, and the signal is input to the ECU. This activates the ECU and starts the telescopic control motor to retract the telescopic while the SW is kept pressed to TELESCO SHORT position.

4. DRIVING POSITION MEMORY FUNCTION

The pulse signals detected by the tilt and telescopic sensors are input to the ECU. This makes it possible to store and recall the desired driving position through communication control of the body ECU and door ECU etc.

SERVICE HINTS

T5 TILT AND TELESCOPIC ECU

5-GROUND : Always approx. 12 volts

10-GROUND : Always approx. 12 volts

2-GROUND : Approx. 12 volts with ignition SW at ON or ST position

1-GROUND : Always continuity

4-GROUND : Always continuity

C15 TILT AND TELESCOPIC SW [COMB. SW]

4-9 : Approx. 160 Ω with TELESCO LONG operation

Approx. 360 Ω with TILT UP operation

Approx. 790 Ω with TELESCO SHORT operation

Approx. 1.99 kΩ with TILT DOWN operation

POWER TILT AND POWER TELESCOPIC

○ : PARTS LOCATION

Code	See Page	Code	See Page	Code	See Page
A13	40	D24	C 42	J13	41
B5	A 40	E5	D 38 (2JZ-GE)	J15	41
B6	A 40	E7	F 36 (1UZ-FE)	J17	41
C13	40	J6	41	M3	41
C15	40	J7	41	T5	41
D22	A 42	J10	41		

○ : RELAY BLOCKS

Code	See Page	Relay Blocks (Relay Block Location)
1	22	Engine Room No.1 R/B (Engine Compartment Right)

○ : JUNCTION BLOCK AND WIRE HARNESS CONNECTOR

Code	See Page	Junction Block and Wire Harness (Connector Location)
1F	26	Cowl Wire and Driver Side J/B (Left Kick Panel)
1G	27	
1H		
2B	28	Engine Room Main Wire and Passenger Side J/B (Right Kick Panel)
2F	28	Cowl Wire and Passenger Side J/B (Right Kick Panel)
2G	29	

□ : CONNECTOR JOINING WIRE HARNESS AND WIRE HARNESS

Code	See Page	Joining Wire Harness and Wire Harness (Connector Location)
IB1	50	Front Door LH Wire and Cowl Wire (Left Kick Panel)
IE1	50	Instrument Panel Wire and Cowl Wire (Left Side of the Steering Column)
IJ1	52	Instrument Panel Wire and Cowl Wire (Left Side of the Blower Unit)

▽ : GROUND POINTS

Code	See Page	Ground Points Location
IF	50	Left Kick Panel
II	50	Right Side of the Cowl Panel

○ : SPLICE POINTS

Code	See Page	Wire Harness with Splice Points	Code	See Page	Wire Harness with Splice Points
I6	52	Cowl Wire			

A13

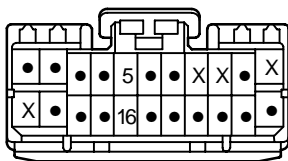

B5 (A)

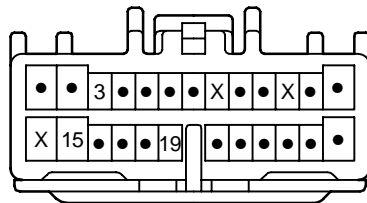

B6 (A)

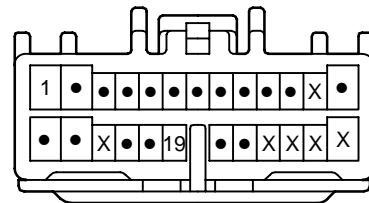

C13

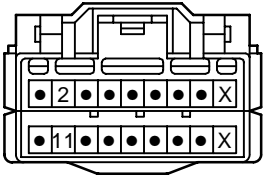

C15

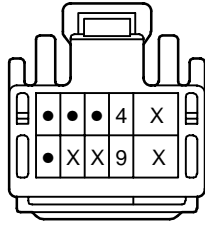

D22 (A)
GRAY

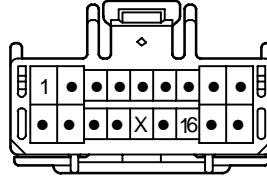

D24 (C)
GRAY

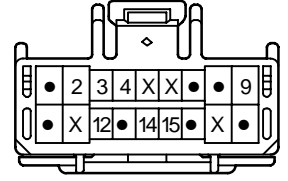

E5 (D)
(2JZ-GE)

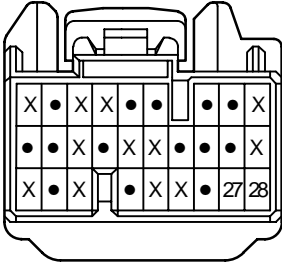

E7 (F)
(1UZ-FE)

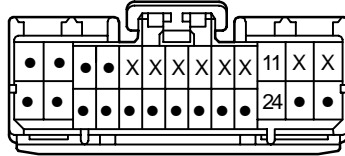

J6

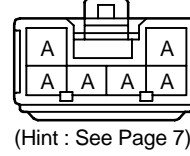

(Hint : See Page 7)

J7
GRAY

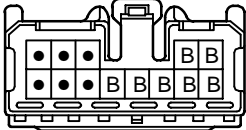

(Hint : See Page 7)

J10
ORANGE

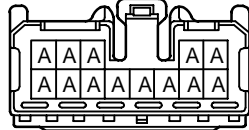

(Hint : See Page 7)

J13

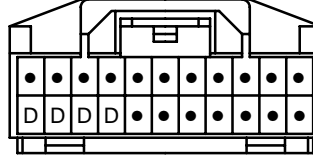

(Hint : See Page 7)

J15

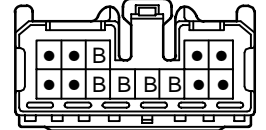

(Hint : See Page 7)

J17

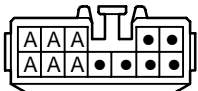

(Hint : See Page 7)

M3
BLUE

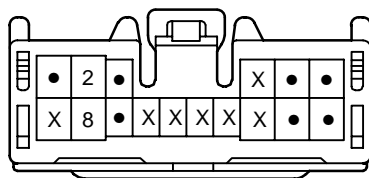

T5
GRAY

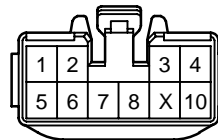

POWER WINDOW

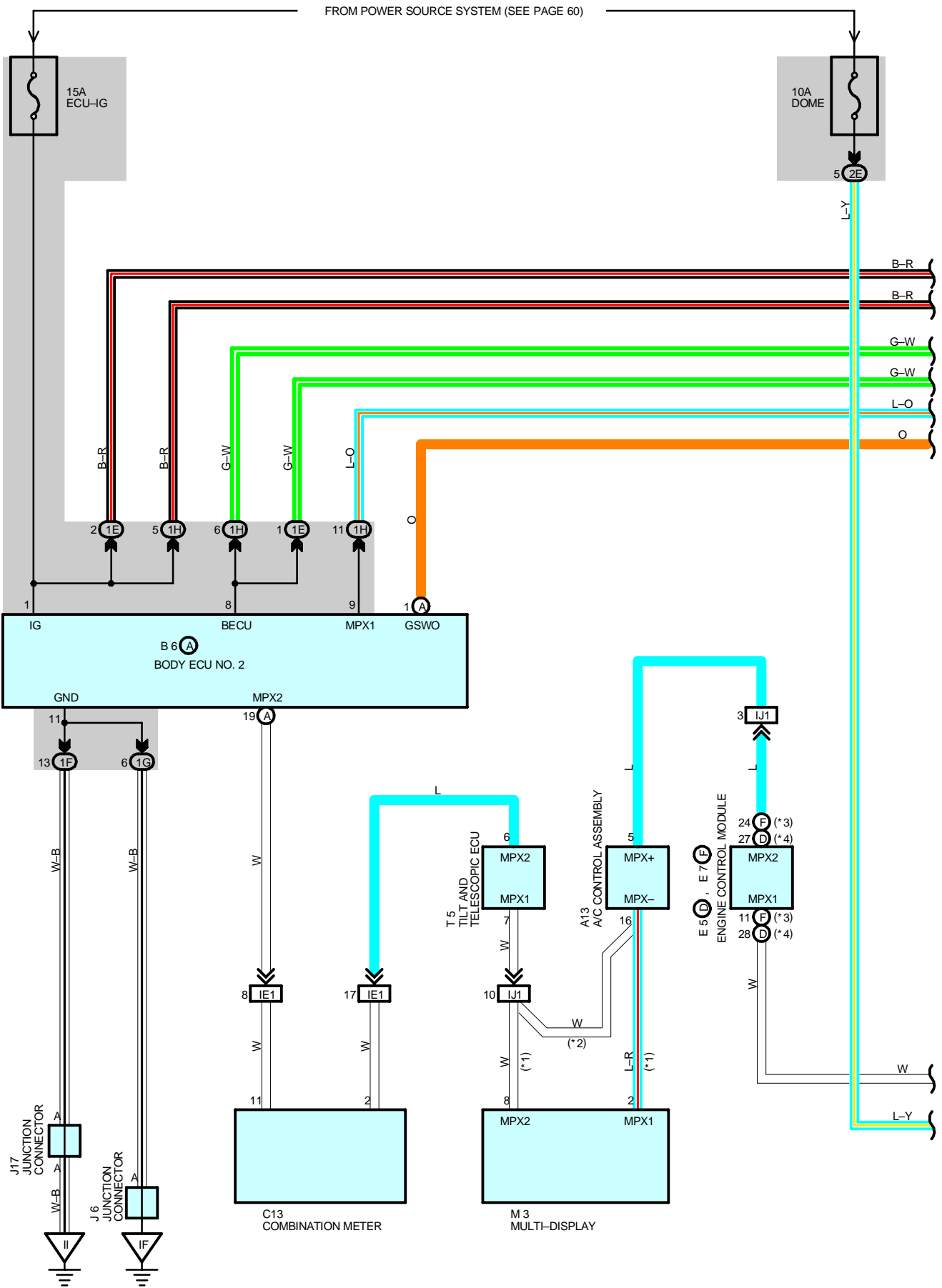

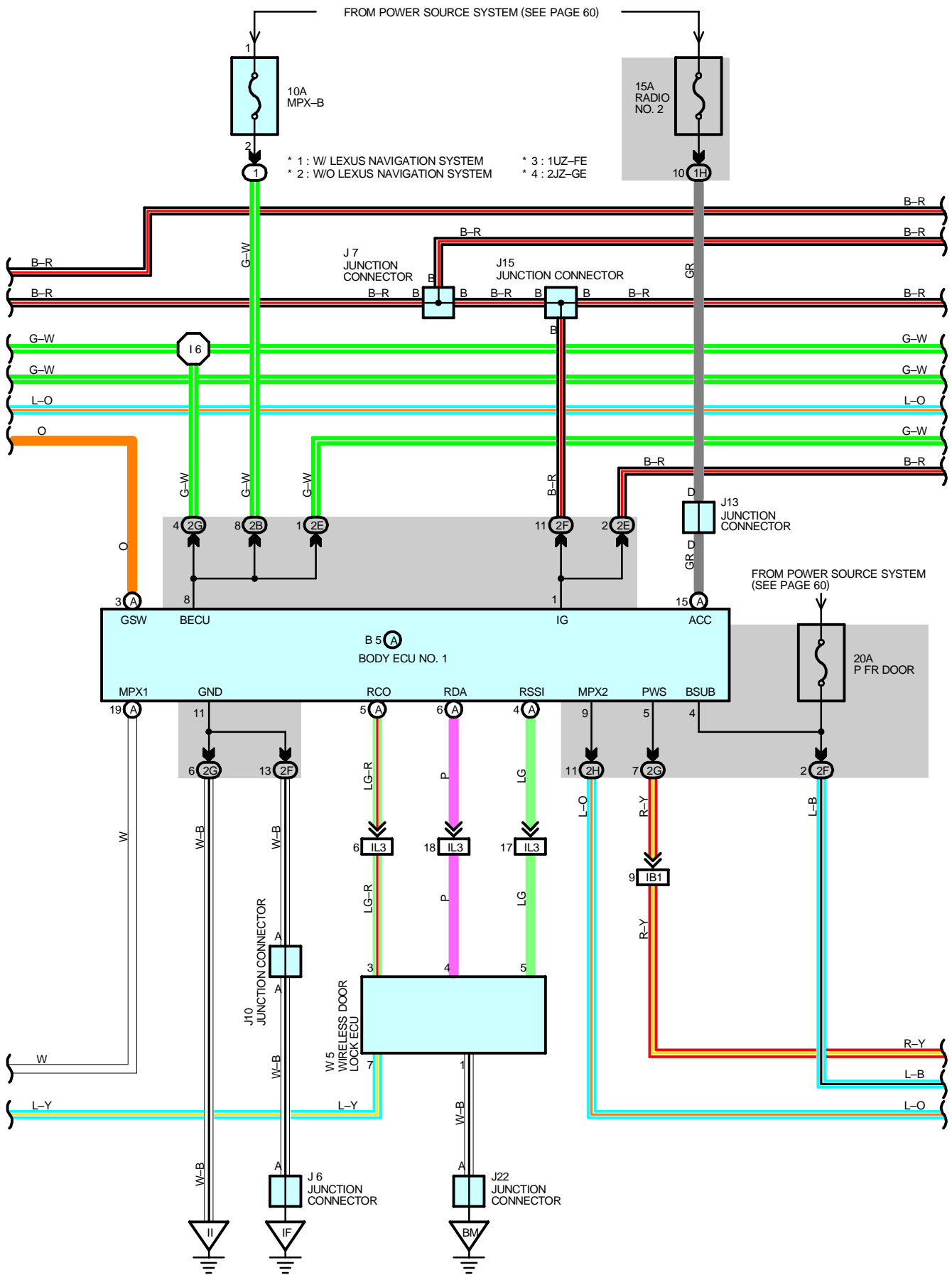

POWER WINDOW



P11
POWER WINDOW MASTER SW

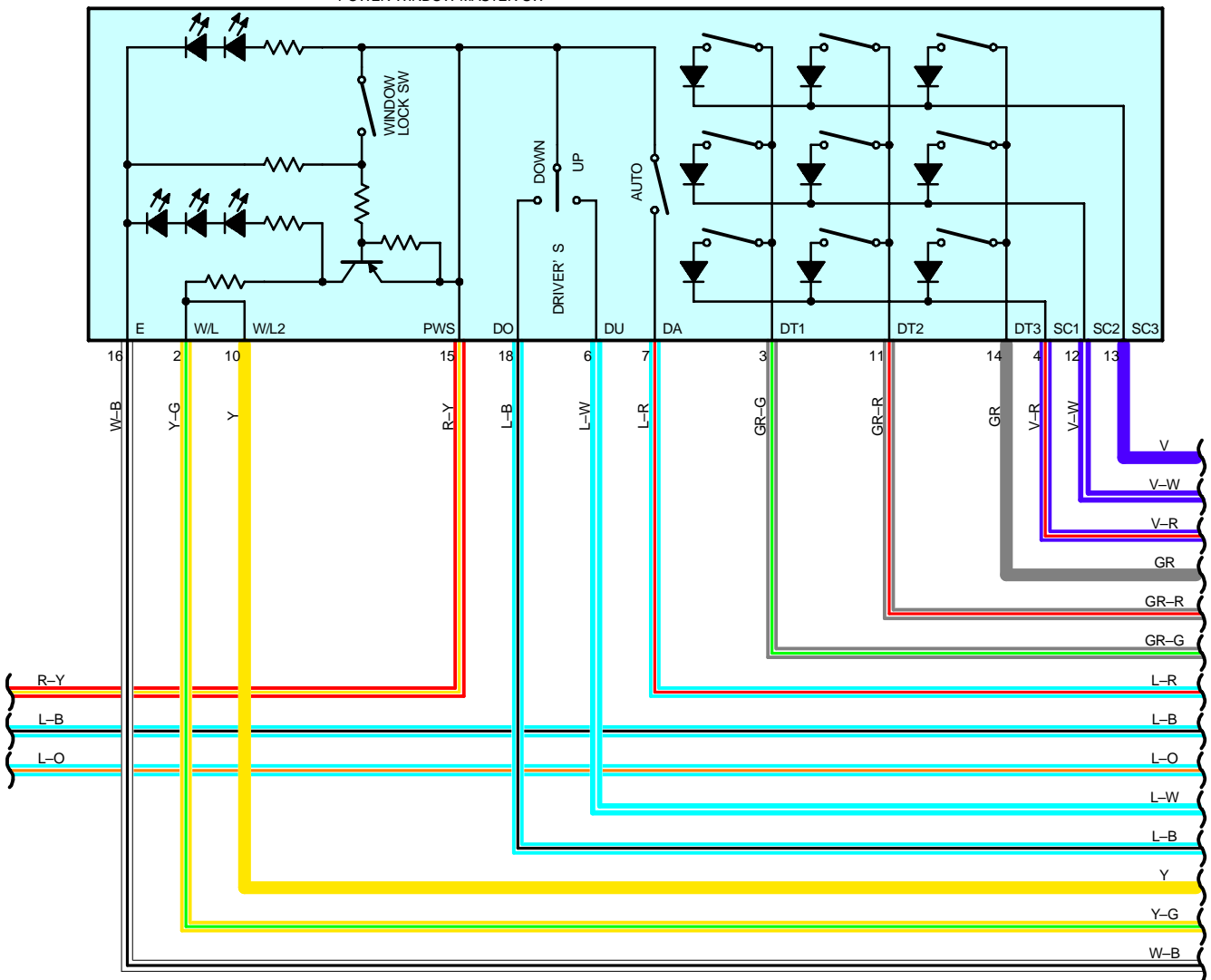

FROM POWER SOURCE SYSTEM (SEE PAGE 60)

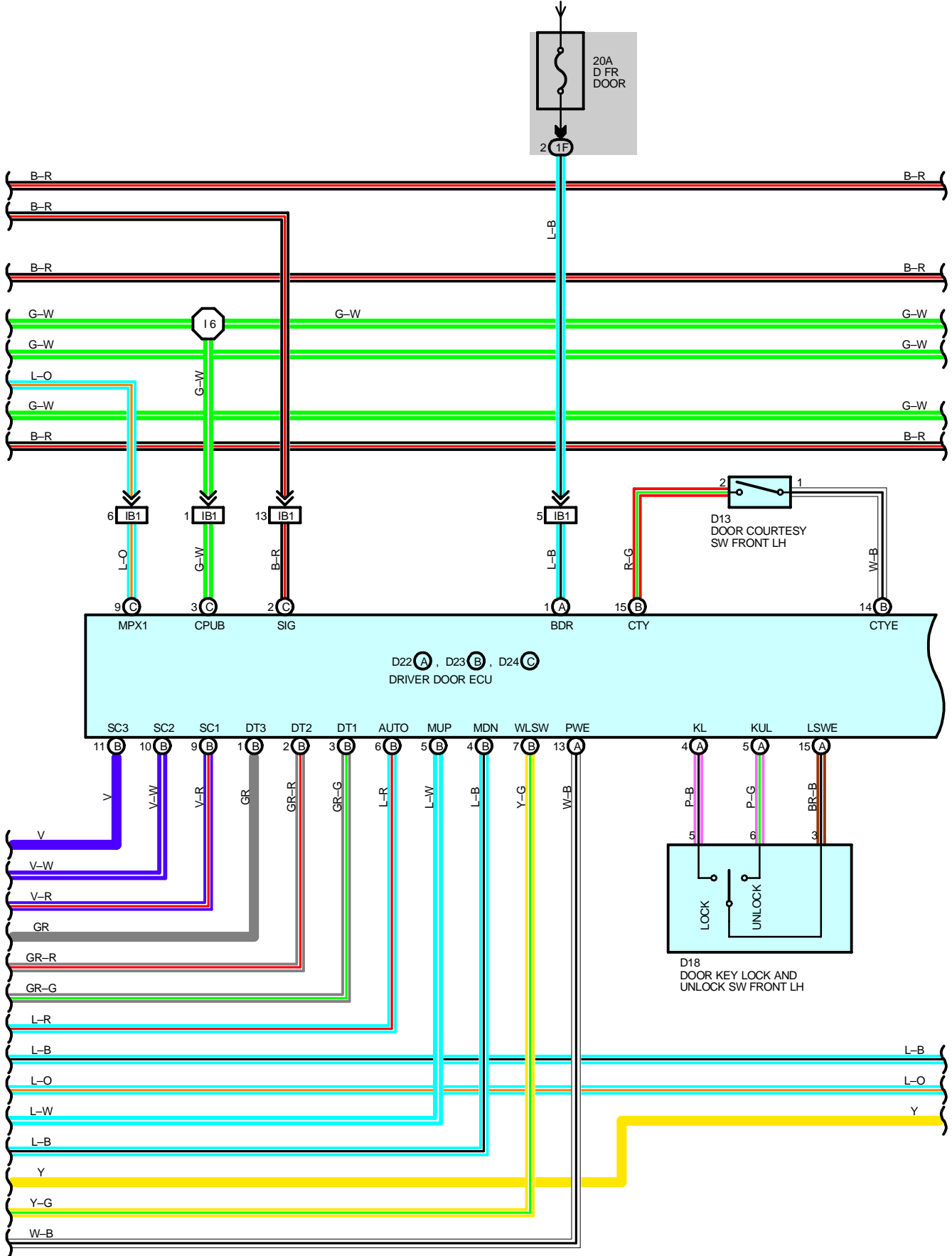

POWER WINDOW

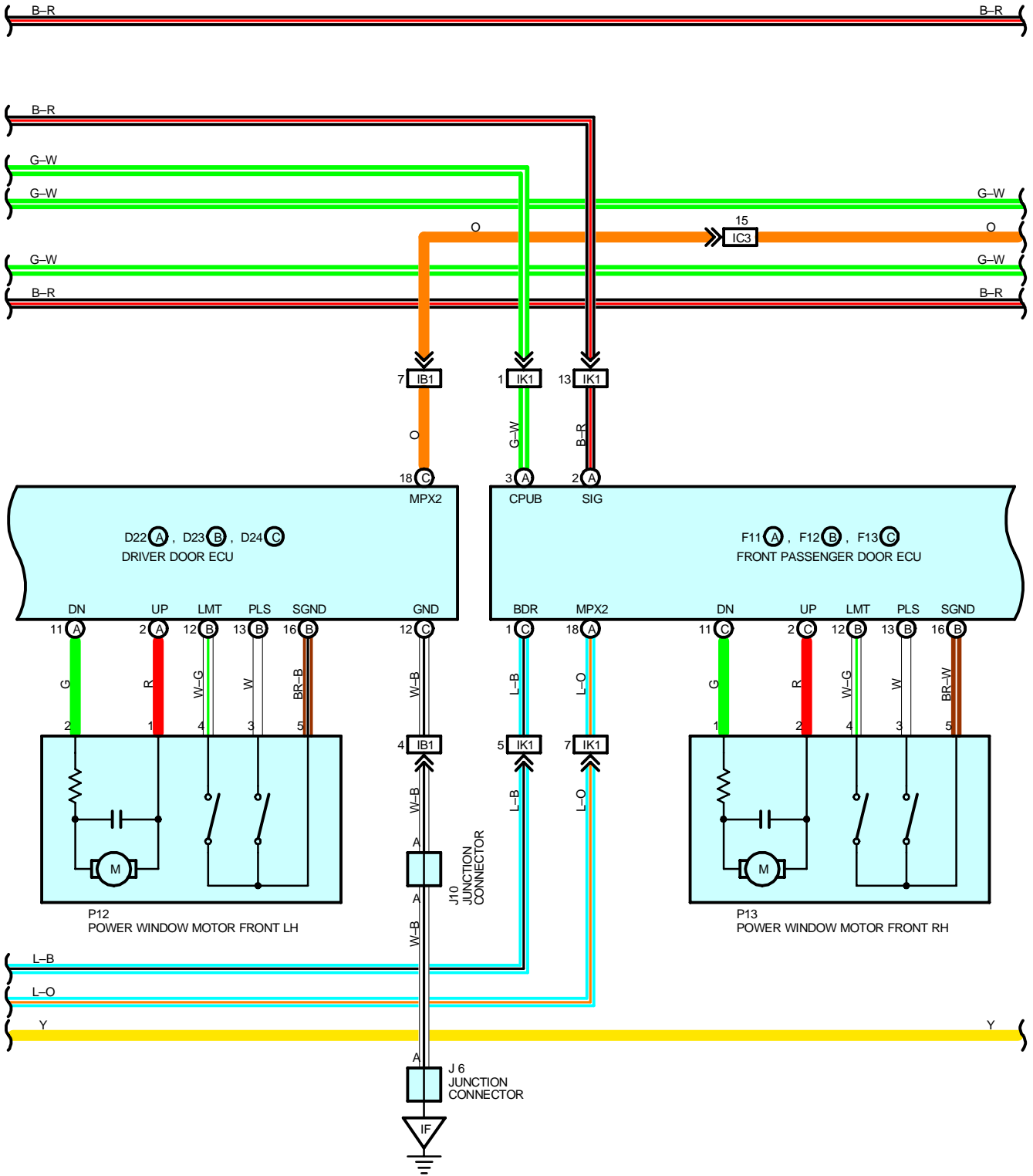

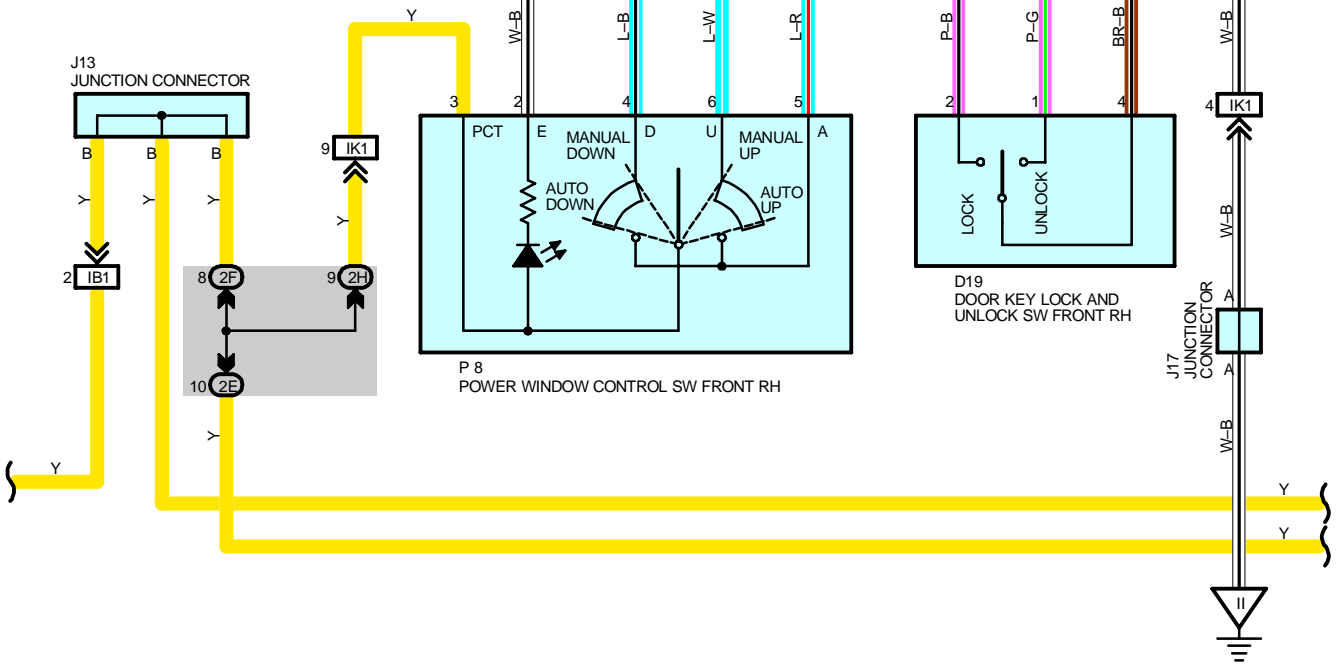
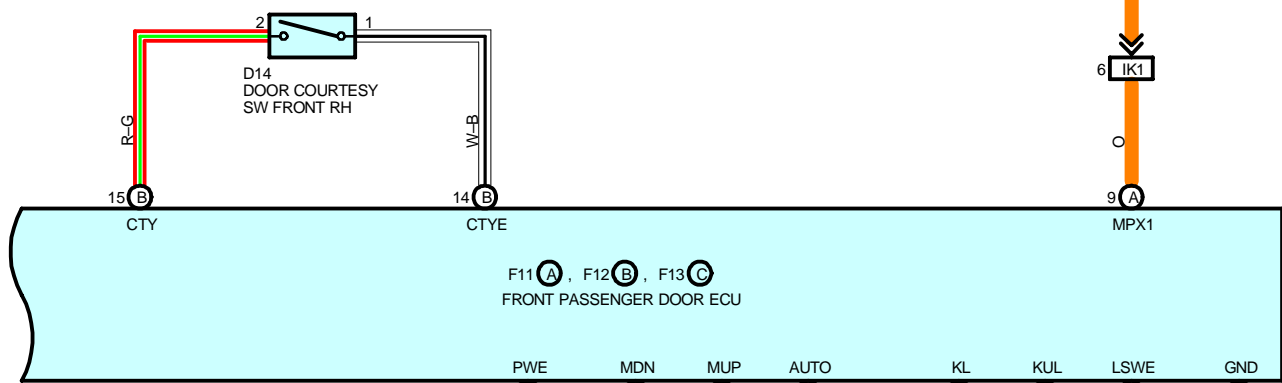
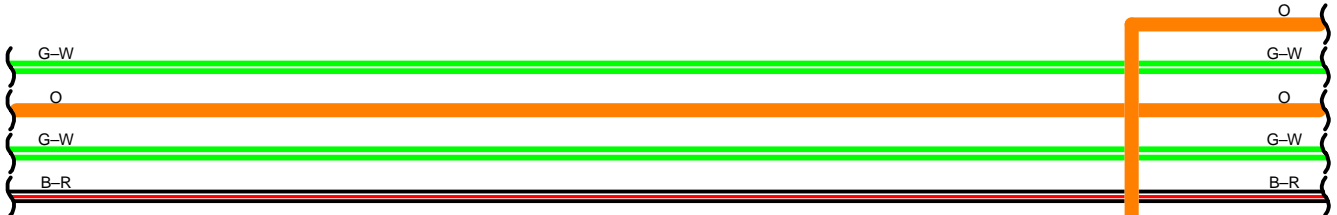

POWER WINDOW

FROM POWER SOURCE SYSTEM (SEE PAGE 60)

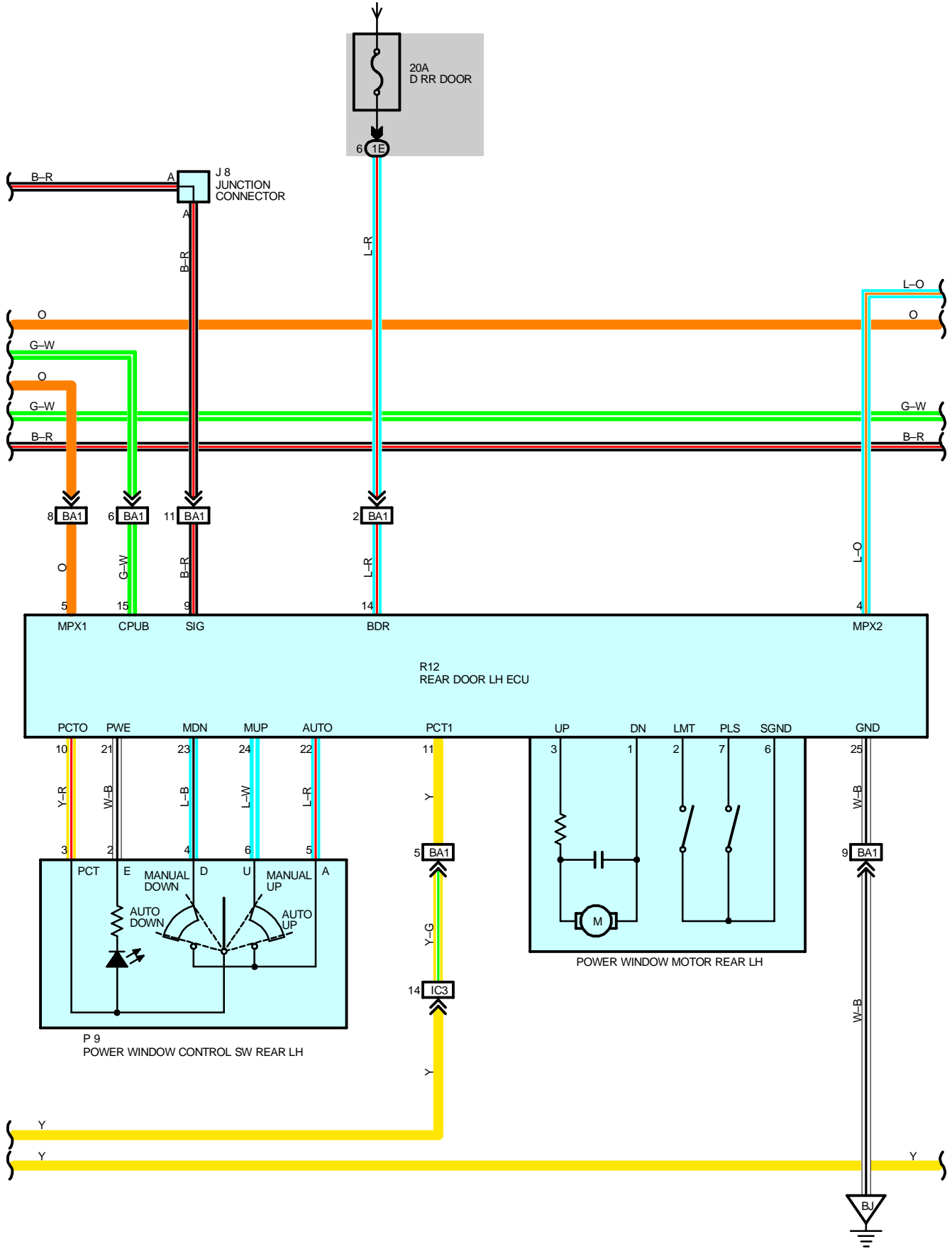

FROM POWER SOURCE SYSTEM (SEE PAGE 60)

* 5 : W/ DRIVING POSITION MEMORY
 * 6 : W/O DRIVING POSITION MEMORY

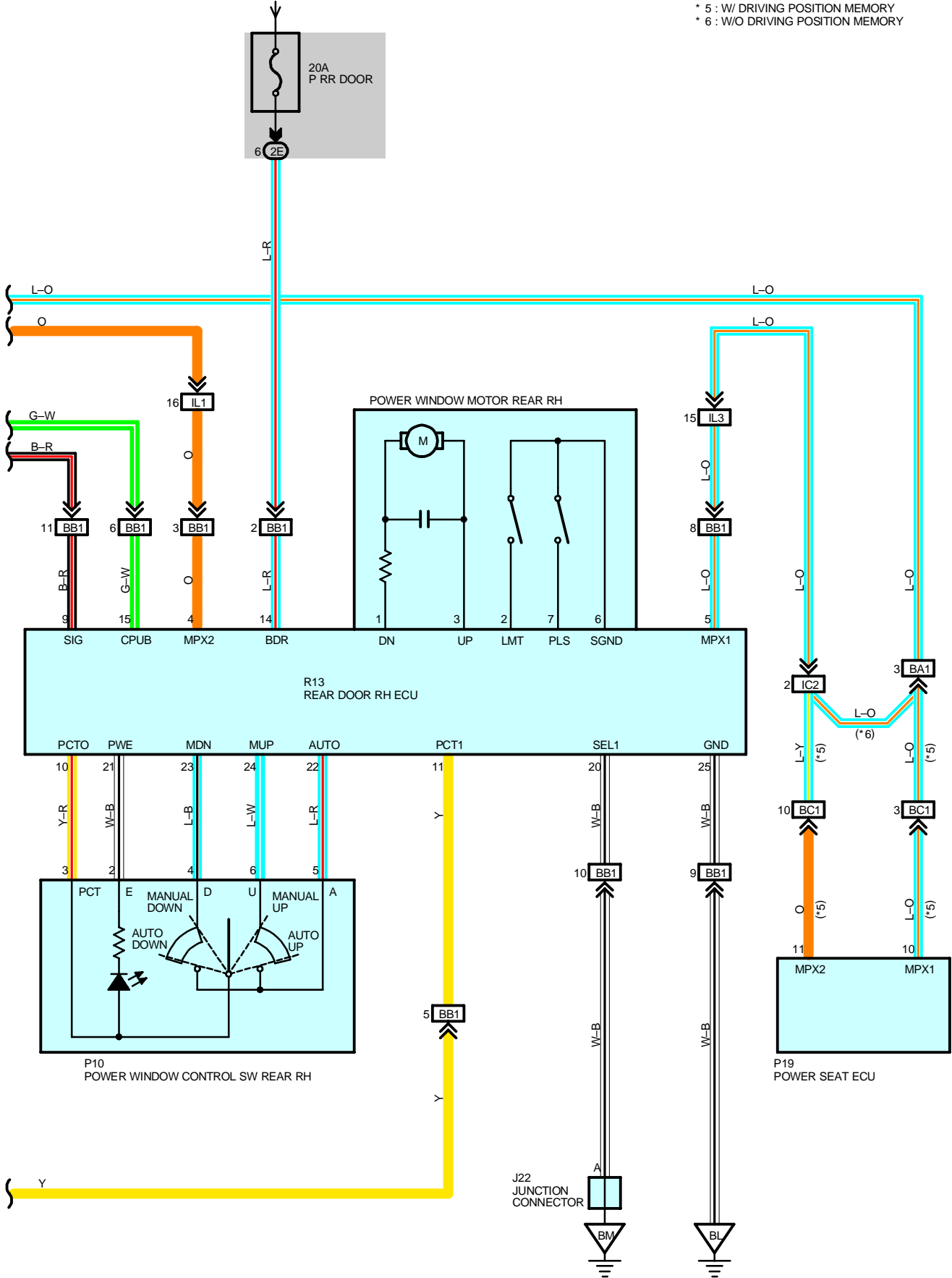

POWER WINDOW

SYSTEM OUTLINE

1. MANUAL DOWN OR UP OPERATION

The signal is input to TERMINAL MDN of the driver door ECU while the power window master SW is kept pressed one step. This activates the driver door ECU to flow the current from TERMINAL DN into the power window motor front LH to TERMINAL UP of the driver door ECU to GROUND, to rotate the motor and open the window.

The signal is input to TERMINAL MUP of the driver door ECU while the power window master SW is kept pulled one step. This activates the driver door ECU to flow the current from TERMINAL UP into the power window motor front LH to TERMINAL DN of the driver door ECU to GROUND, to reversely rotate the motor and close the window. For other windows, as the power window master SW or each power window SW is operated, the window of the relevant door is opened or closed.

2. AUTO DOWN OR UP OPERATION

The signals are input to TERMINALS MDN and AUTO of the driver door ECU when the power window master SW is pressed two steps. According to these signals, it is determined that the driver door ECU is in the auto mode. The current flows from TERMINAL DN into the power window motor front LH to TERMINAL UP of the driver door ECU to GROUND, to rotate the motor and automatically open the window. Accordingly, when each window switch of the power window master SW is pressed, the window of the relevant door is automatically opened through communication control of the body ECU and door ECU etc.

The signals are input to TERMINALS MUP and AUTO of the driver door ECU when the power window master SW is pulled two steps. According to these signals, it is determined that the driver door ECU is in the auto mode. The current flows from TERMINAL UP into the power window motor front LH to TERMINAL DN of the driver door ECU to GROUND, to rotate the motor and automatically close the window. Accordingly, when each window switch of the power window master SW is pressed, the window of the relevant door is automatically closed through communication control of the body ECU and door ECU etc.

For other windows, as each power window control SW is operated, the window of the relevant door is automatically opened or closed.

3. POWER WINDOW OPERATION LINKED WITH DOOR KEY LOCK AND UNLOCK SW

When the ignition key is inserted into the door key cylinder on the driver or passenger side and kept turned to the lock or unlock position for approximately 1.5 sec. or longer, all the door windows can be opened or closed.

Power window close operation

When the ignition key is inserted into the door key cylinder and kept turned to the lock position for 1.5 sec. or longer, the signal from the door key lock and unlock SW is input to TERMINAL KL of the driver door ECU or front passenger door ECU. Through communication control of the body ECU and door ECU etc. , the current flows from TERMINAL UP of each door ECU into the power window motor to TERMINAL DN of the each door ECU to GROUND, to close all the door windows.

Power window open operation

When the ignition key is inserted into the door key cylinder and kept turned to the unlock position for 1.5 sec. or longer, the signal from the door key lock and unlock SW is input to TERMINAL KUL of the driver door ECU or front passenger door ECU. Through communication control of the body ECU and door ECU etc. , the current flows from TERMINAL DN of each door ECU into the power window motor to TERMINAL UP of the each door ECU to GROUND, to close all the door windows.

If any of the following conditions is detected, the power window operation is stopped.

Approximately 10 sec. or longer has elapsed after starting open/close operation. Catching prevention function is activated.

4. POWER WINDOW OPERATION LINKED WITH TRANSMITTER

When the unlock SW on the transmitter of the ignition key is kept pressed for 1.5 sec. or longer, all the door windows can be opened.

Power window open operation

When the unlock SW of the ignition key is kept pressed for 1.5 sec. or longer, the frequency received from the wireless door lock control ECU is input to the body ECU No.1. Through communication control of the body ECU and door ECU etc. , the current flows from TERMINAL DN of each door ECU into the power window motor to TERMINAL UP of the each door ECU to GROUND, to open all the door windows.

If any of the following conditions is detected, the power window operation is stopped.

Approximately 10 sec. or longer have elapsed after starting open operation.

The lock or unlock switch on the transmitter is released.

Catching prevention function is activated.

5. CATCHING PREVENTION FUNCTION

If any foreign matter is caught in the window while it is rising, the pulse sensor installed in the power window motor detects changes in the number of motor rotations, forcibly lowers the door window 50 mm or if the door window opening amount is 200 mm or less, the window is lowered so that the opening amount is 200 mm.

6. KEY OFF POWER WINDOW OPERATION

It is possible to operate the power window for 45 sec. after the ignition key is turned from ON to OFF and the driver or front passenger door is opened. However, when the door is closed while the window is being operated, the power window operation is stopped even though 45 sec. has not elapsed.

SERVICE HINTS

B6 BODY ECU NO.2

- 1-GROUND : Approx. **12** volts with ignition SW at **ON** or **ST** position
- 8-GROUND : Always approx. **12** volts
- 11-GROUND : Always continuity

B5 (A) BODY ECU NO.1

- 1-GROUND : Approx. **12** volts with ignition SW at **ON** or **ST** position
- 8-GROUND : Always approx. **12** volts
- 11-GROUND : Always continuity
- 4-GROUND : Always approx. **12** volts
- (A)15-GROUND : Approx. **12** volts with ignition SW at **ACC** or **ON** position

D22 (A), D24 (C) DRIVER DOOR ECU

- (A) 1-GROUND : Always approx. **12** volts
- (C) 3-GROUND : Always approx. **12** volts
- (C) 2-GROUND : Approx. **12** volts with ignition SW at **ON** or **ST** position
- (C)12-GROUND : Always continuity

F11 (A), F13 (C) FRONT PASSENGER DOOR ECU

- (A) 2-GROUND : Approx. **12** volts with ignition SW at **ON** or **ST** position
- (A) 3-GROUND : Always approx. **12** volts
- (A)12-GROUND : Always continuity
- (C) 1-GROUND : Always approx. **12** volts

R12 REAR DOOR LH ECU

- 9-GROUND : Approx. **12** volts with ignition SW at **ON** or **ST** position
- 14-GROUND : Always approx. **12** volts
- 15-GROUND : Always approx. **12** volts
- 25-GROUND : Always continuity

R13 REAR DOOR RH ECU

- 9-GROUND : Approx. **12** volts with ignition SW at **ON** or **ST** position
- 15-GROUND : Always approx. **12** volts
- 14-GROUND : Always approx. **12** volts
- 20-GROUND : Always continuity
- 25-GROUND : Always continuity

P11 POWER WINDOW MASTER SW

- 15-6 : Closed with power window master SW at **MANUAL UP** position
- 15-18 : Closed with power window master SW at **MANUAL DOWN** position
- 15-6, 7 : Closed with power window master SW at **AUTO UP** position
- 15-18, 7 : Closed with power window master SW at **AUTO DOWN** position

P8, P9, P10 POWER WINDOW CONTROL SW FRONT RH, REAR LH, REAR RH

- 3-6 : Closed with power window SW at **MANUAL UP** operation
- 3-4 : Closed with power window SW at **MANUAL DOWN** operation
- 3-6, 5 : Closed with power window SW at **AUTO UP** operation
- 3-4, 5 : Closed with power window SW at **AUTO DOWN** operation

WINDOW LOCK SW

- Open with window lock SW at **LOCK** position

POWER WINDOW

○ : PARTS LOCATION

Code	See Page	Code	See Page	Code	See Page		
A13	40	E7	F	36 (1UZ-FE)	M3	41	
B5	A	40	F11	A	42	P8	43
B6	A	40	F12	B	42	P9	43
C13	40	F13	C	42	P10	43	
D13	42	J6	41	P11	43		
D14	42	J7	41	P12	43		
D18	42	J8	41	P13	43		
D19	42	J10	41	P19	44		
D22	A	42	J13	41	R12	43	
D23	B	42	J15	41	R13	43	
D24	C	42	J17	41	T5	41	
E5	D	38 (2JZ-GE)	J22	42	W5	43	

○ : RELAY BLOCKS

Code	See Page	Relay Blocks (Relay Block Location)
1	22	Engine Room No.1 R/B (Engine Compartment Right)

○ : JUNCTION BLOCK AND WIRE HARNESS CONNECTOR

Code	See Page	Junction Block and Wire Harness (Connector Location)
1E	26	Floor No.2 Wire and Driver Side J/B (Left Kick Panel)
1F	26	Cowl Wire and Driver Side J/B (Left Kick Panel)
1G	27	
1H		
2B	28	Engine Room Main Wire and Passenger Side J/B (Right Kick Panel)
2E	28	Floor No.1 Wire and Passenger Side J/B (Right Kick Panel)
2F	28	Cowl Wire and Passenger Side J/B (Right Kick Panel)
2G	29	
2H		

□ : CONNECTOR JOINING WIRE HARNESS AND WIRE HARNESS

Code	See Page	Joining Wire Harness and Wire Harness (Connector Location)
IB1	50	Front Door LH Wire and Cowl Wire (Left Kick Panel)
IC2	50	Floor No.2 Wire and Cowl Wire (Left Kick Panel)
IC3		
IE1	50	Instrument Panel Wire and Cowl Wire (Left Side of the Steering Column)
IJ1	52	Instrument Panel Wire and Cowl Wire (Left Side of the Blower Unit)
IK1	52	Front Door RH Wire and Cowl Wire (Right Kick Panel)
IL1	52	Floor No.1 Wire and Cowl Wire (Right Kick Panel)
IL3		
BA1	54	Rear Door LH Wire and Floor No.2 Wire (Under the Center Pillar LH)
BB1	54	Rear Door RH Wire and Floor No.1 Wire (Under the Center Pillar RH)
BC1	56	Floor No.2 Wire and Front Seat LH Wire (Under the Driver's Seat)

▽ : GROUND POINTS

Code	See Page	Ground Points Location
IF	50	Left Kick Panel
II	50	Right Side of the Cowl Panel
BJ	54	Rear Floor Partition Panel LH
BL	54	Rear Floor Partition Panel RH
BM	54	Quarter Panel RH



: SPLICE POINTS

Code	See Page	Wire Harness with Splice Points	Code	See Page	Wire Harness with Splice Points
I6	52	Cowl Wire			

A13

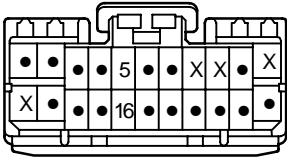

B5 (A)

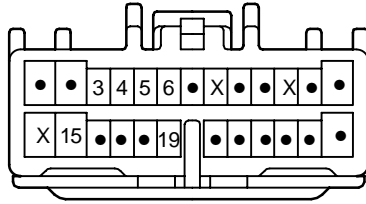

B6 (A)

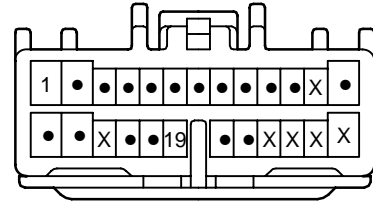

C13

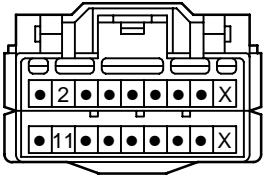

D13
GRAY

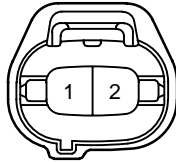

D14
GRAY

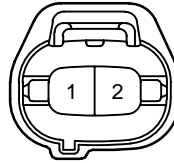

D18
BLACK

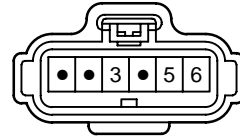

D19
BLACK

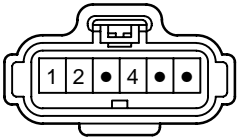

D22 (A)
GRAY

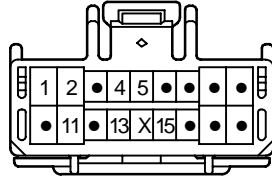

D23 (B)
GRAY

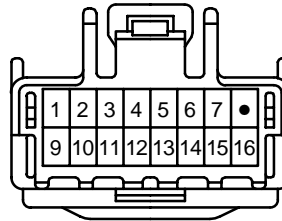

D24 (C)
GRAY

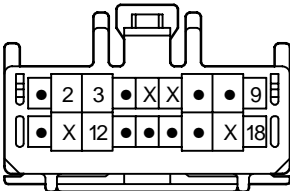

E5 (D)
(2JZ-GE)

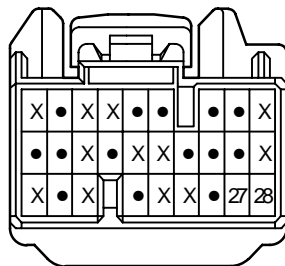

E7 (F)
(1UZ-FE)

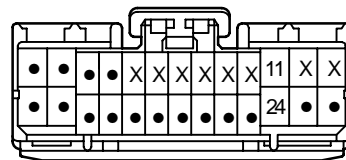

F11 (A)
GRAY

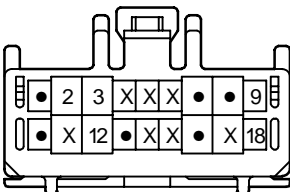

F12 (B)
GRAY

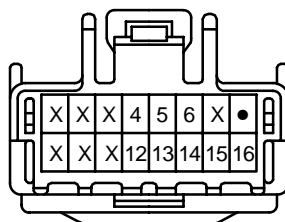

F13 (C)
GRAY

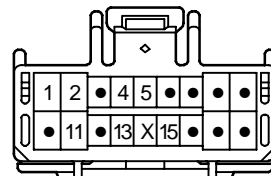

J6

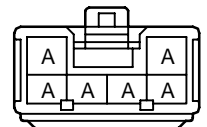

(Hint : See Page 7)

POWER WINDOW

J7
GRAY

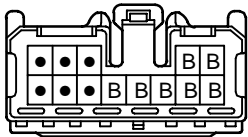

(Hint : See Page 7)

J8
BLACK



(Hint : See Page 7)

J10
ORANGE

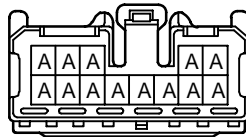

(Hint : See Page 7)

J13

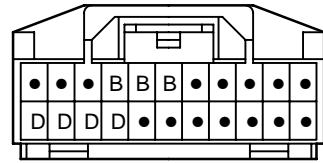

(Hint : See Page 7)

J15

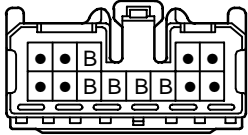

(Hint : See Page 7)

J17

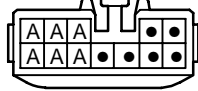

(Hint : See Page 7)

J22

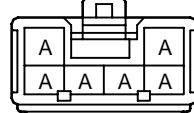

(Hint : See Page 7)

M3
BLUE

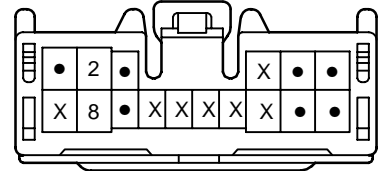

P8

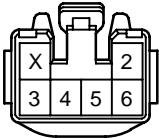

P9

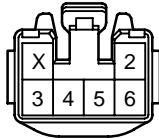

P10

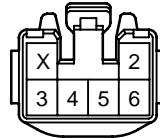

P11

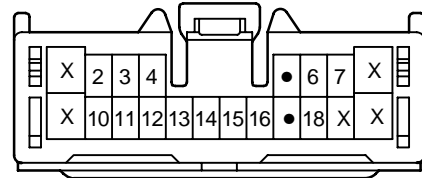

P12

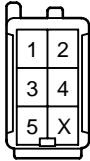

P13

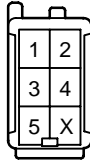

P19

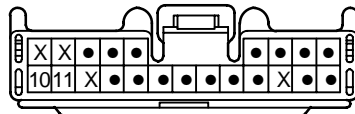

R12

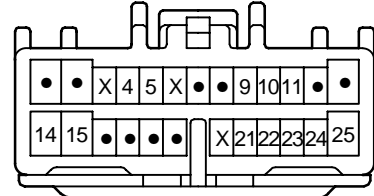

R13

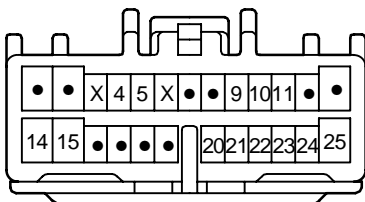

T5
GRAY

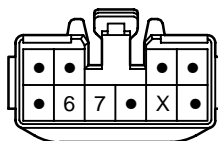

W5

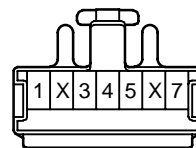

FROM POWER SOURCE SYSTEM (SEE PAGE 60)

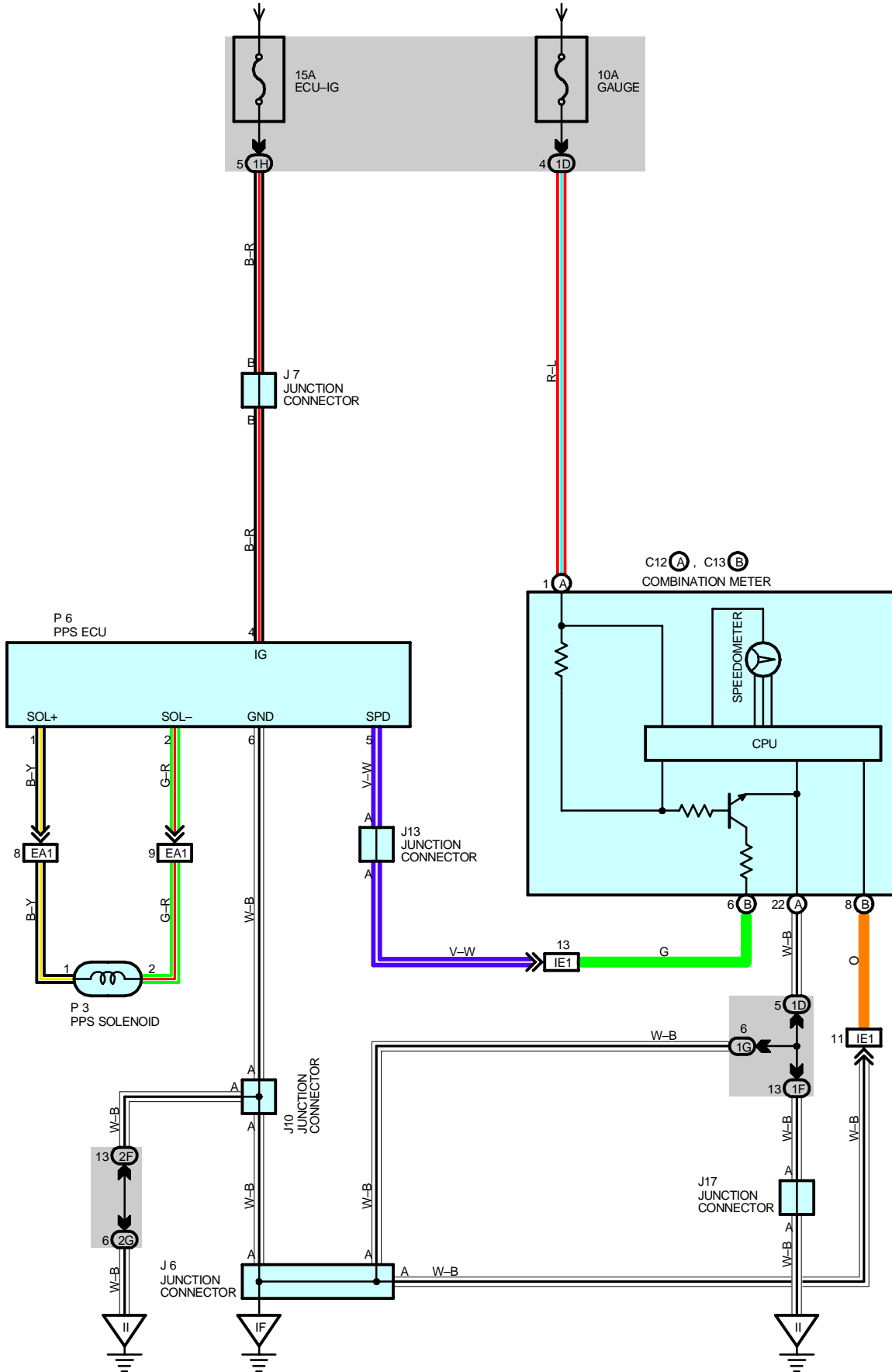

SYSTEM OUTLINE

PPS ECU (Flow rate control system) controls the solenoid valves mounted in the pump to conduct direct control of the pump flow rate in response to the vehicle speed possible, ensuring natural and real steering feeling.

1. PPS OPERATION

When the ignition SW is turned on, the starting current flows from the ECU-IG fuse to TERMINAL 4 of the PPS ECU. The vehicle speed sensor monitors the vehicle speed and transmits control signals to TERMINAL 5 of the ECU.

When the vehicle speed is low, the PPS ECU sends a higher-current from TERMINAL 1 of the ECU to TERMINAL 1 of the PPS solenoid to TERMINAL 2 to TERMINAL 2 of the ECU to TERMINAL 6 to GROUND, increasing the solenoid valve opening angle to provide comfortable steering operation. When the vehicle speed is high, the PPS ECU decreases the solenoid valve opening angle by reducing the current to the valve to provide responsive steering feeling.

SERVICE HINTS

P3 PPS SOLENOID

1-2 : Approx. **7.8 Ω** (25°C, 77°F)

P6 PPS ECU

4-GROUND : Approx. **12** volts with ignition SW at **ON** or **ST** position

6-GROUND : Always continuity

○ : PARTS LOCATION

Code		See Page	Code	See Page	Code	See Page
C12	A	40	J10	41	P3	39 (2JZ-GE)
C13	B	40	J13	41	P6	41
J6		41	J17	41		
J7		41	P3	37 (1UZ-FE)		

○ : JUNCTION BLOCK AND WIRE HARNESS CONNECTOR

Code	See Page	Junction Block and Wire Harness (Connector Location)
1D	26	Instrument Panel Wire and Driver Side J/B (Left Kick Panel)
1F	26	Cowl Wire and Driver Side J/B (Left Kick Panel)
1G	27	
1H		
2F	28	Cowl Wire and Passenger Side J/B (Right Kick Panel)
2G	29	

□ : CONNECTOR JOINING WIRE HARNESS AND WIRE HARNESS

Code	See Page	Joining Wire Harness and Wire Harness (Connector Location)
EA1	46 (1UZ-FE)	Engine Wire and Cowl Wire (Inside of the ECU Box)
	48 (2JZ-GE)	
IE1	50	Instrument Panel Wire and Cowl Wire (Left Side of the Steering Column)

▽ : GROUND POINTS

Code	See Page	Ground Points Location
IF	50	Left Kick Panel
II	50	Right Side of the Cowl Panel

C12 (A)

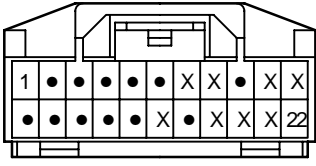

C13 (B)

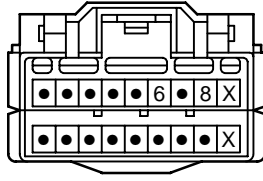

J6

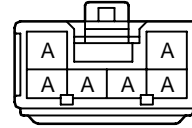

(Hint : See Page 7)

J7
GRAY

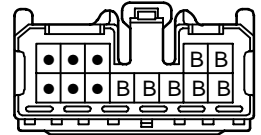

(Hint : See Page 7)

J10
ORANGE

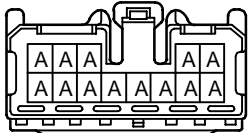

(Hint : See Page 7)

J13

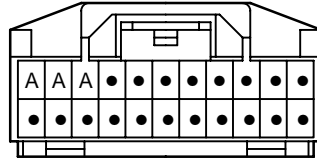

(Hint : See Page 7)

J17

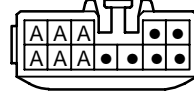

(Hint : See Page 7)

P3
GRAY

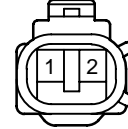

P6
BLUE

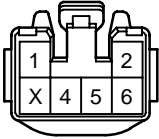

RADIATOR FAN AND CONDENSER FAN

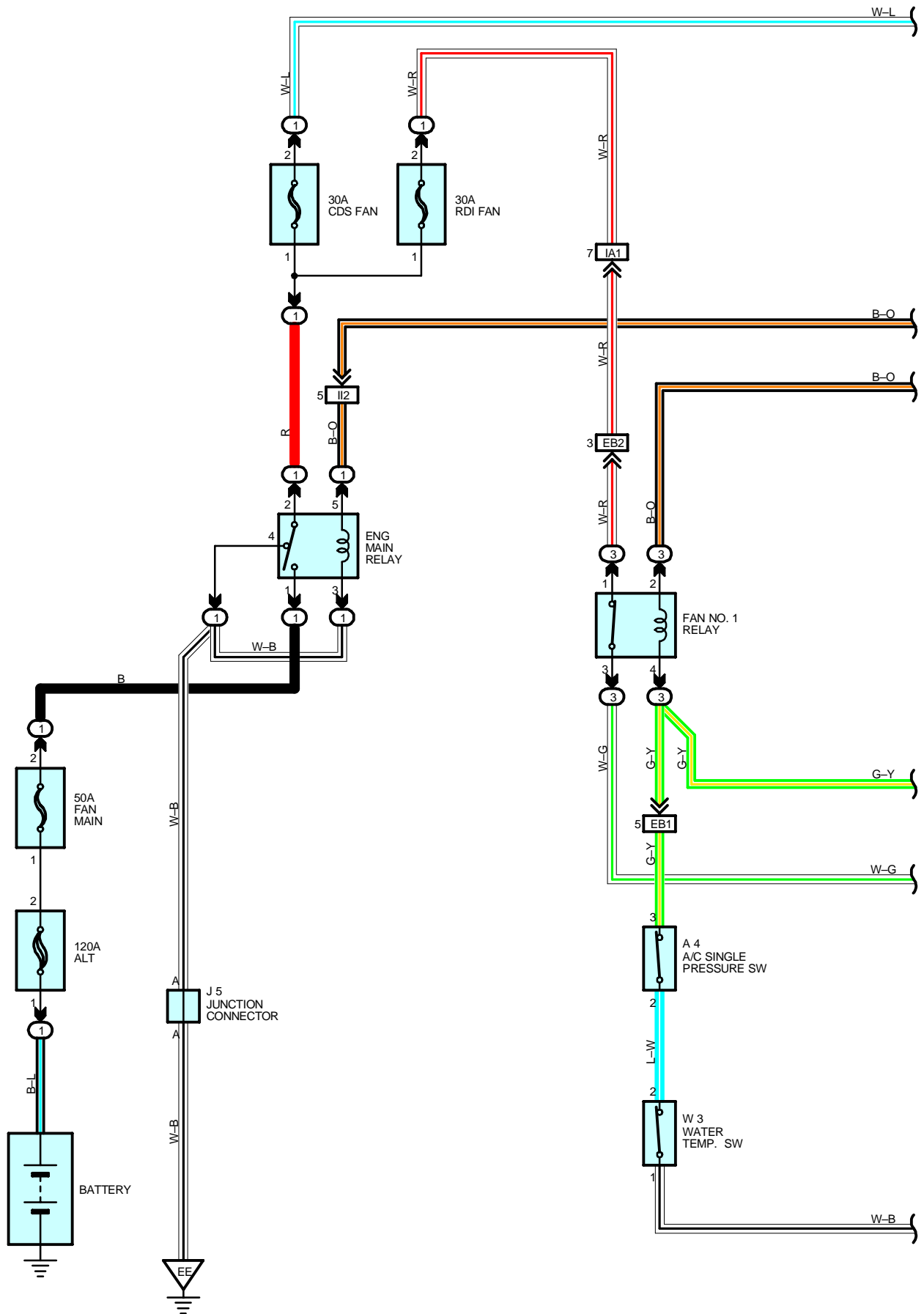

RADIATOR FAN AND CONDENSER FAN

SYSTEM OUTLINE

FAN MOTOR OPERATION

When the ignition SW is turned on, the current from the IGN fuse flows to the FAN NO.1 relay (Coil side) and the FAN NO.2 relay (Coil side) to TERMINAL 3 of the A/C single pressure SW to TERMINAL 2 to TERMINAL 2 of the water temp. SW to TERMINAL 1 to GROUND, and the FAN NO.1 relay is turned off and the FAN NO.2 relay is turned on.

* Low speed operation

When the ignition SW is turned on and the A/C is activated, current flows from the A/C COMP relay (Point side) to the FAN NO.3 relay (Coil side) to GROUND, and the FAN NO.3 relay is turned on. As a result, current from the CDS FAN fuse flows to TERMINAL 2 of the A/C condenser fan motor to TERMINAL 1 to the FAN NO.2 relay (Point side) to the FAN NO.3 relay (Point side) to TERMINAL 2 of the radiator fan motor to TERMINAL 1 to GROUND, rotating both of the fan motors at low speed.

If the engine coolant temperature is approx. 90°C (194°F) or less, and the refrigerant pressure is approx. 15.5 kgf/cm² (1520 kpa, 220.4 psi) or less, both the water temp. SW and the A/C signal pressure SW are closed, so that the FAN NO.1 relay is turned off and the FAN NO.2 relay is turned on. As a result, both of the fan motor operate at low speed.

* High speed operation

When, during A/C operation, the refrigerant pressure becomes higher than ordinary level (Approx. 15.5 kgf/cm² (1520 psi, 220.4 kpa)), the A/C single pressure SW is turned off. As a result, the FAN NO.1 relay is turned on and FAN NO.2 relay is turned off, and the current flows from the RDI FAN fuse to FAN NO.1 relay (Point side) to TERMINAL 2 of the radiator fan motor to TERMINAL 1 to GROUND, and current from the CDS FAN fuse flows to TERMINAL 2 of the A/C condenser fan motor to TERMINAL 1 to the FAN NO.2 relay (Point side) to GROUND, rotating both of the fan motors in parallel, thus causing the fan motors to operate at high speed.

Note that, because the current flows in the same manner even if the coolant temperature is approx. 90°C (194°F) or higher, the fan motors still operate at high speed.

SERVICE HINTS

A4 A/C SINGLE PRESSURE SW

2-3 : Open above approx. 15.5 kgf/cm² (220.4 psi, 1520 kpa)
Close below approx. 12.5 kgf/cm² (177.7 psi, 1225.8 kpa)

W3 WATER TEMP. SW

1-2 : Open above approx. 90°C (194°F)
Closed below approx. 83°C (181.4°F)

○ : PARTS LOCATION

Code	See Page	Code	See Page	Code	See Page
A2	36 (1UZ-FE)	J5	37 (1UZ-FE)	R1	39 (2JZ-GE)
	38 (2JZ-GE)		39 (2JZ-GE)	W3	37 (1UZ-FE)
A4	36 (1UZ-FE)	J14	41		
	38 (2JZ-GE)	R1	37 (1UZ-FE)		

○ : RELAY BLOCKS

Code	See Page	Relay Blocks (Relay Block Location)
1	22	Engine Room No.1 R/B (Engine Compartment Right)
3	24	Engine Room No.3 R/B (Engine Compartment Left)

○ : JUNCTION BLOCK AND WIRE HARNESS CONNECTOR

Code	See Page	Junction Block and Wire Harness (Connector Location)
1G	27	Cowl Wire and Driver Side J/B (Left Kick Panel)

□ : CONNECTOR JOINING WIRE HARNESS AND WIRE HARNESS

Code	See Page	Joining Wire Harness and Wire Harness (Connector Location)
EB1	46 (1UZ-FE)	Cowl Wire and Relay Block Wire (Inside of the Engine Room No.3 R/B)
	48 (2JZ-GE)	
EB2	46 (1UZ-FE)	
	48 (2JZ-GE)	
IA1	50	Engine Room Main Wire and Cowl Wire (Near the Driver Side J/B)
II2	52	Engine Room Main Wire and Cowl Wire (Near the Passenger Side R/B)

▽ : GROUND POINTS

Code	See Page	Ground Points Location
EB	46 (1UZ-FE)	Left Fender
	48 (2JZ-GE)	
EE	46 (1UZ-FE)	Under the ABS & TRAC & VSC Actuator
	48 (2JZ-GE)	
IG	50	Left Side of the Cowl Panel

○ : SPLICE POINTS

Code	See Page	Wire Harness with Splice Points	Code	See Page	Wire Harness with Splice Points
E4	46 (1UZ-FE)	Cowl Wire	I1	52	Cowl Wire
	48 (2JZ-GE)				

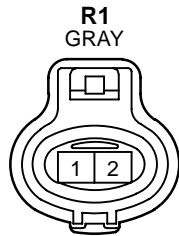
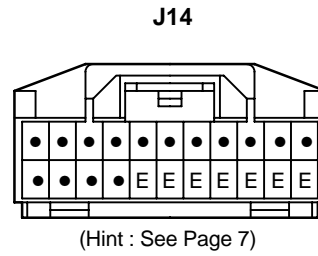
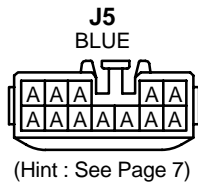
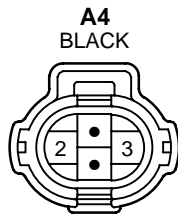
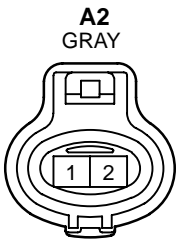

RADIO AND PLAYER (EXCEPT NAKAMICHI)

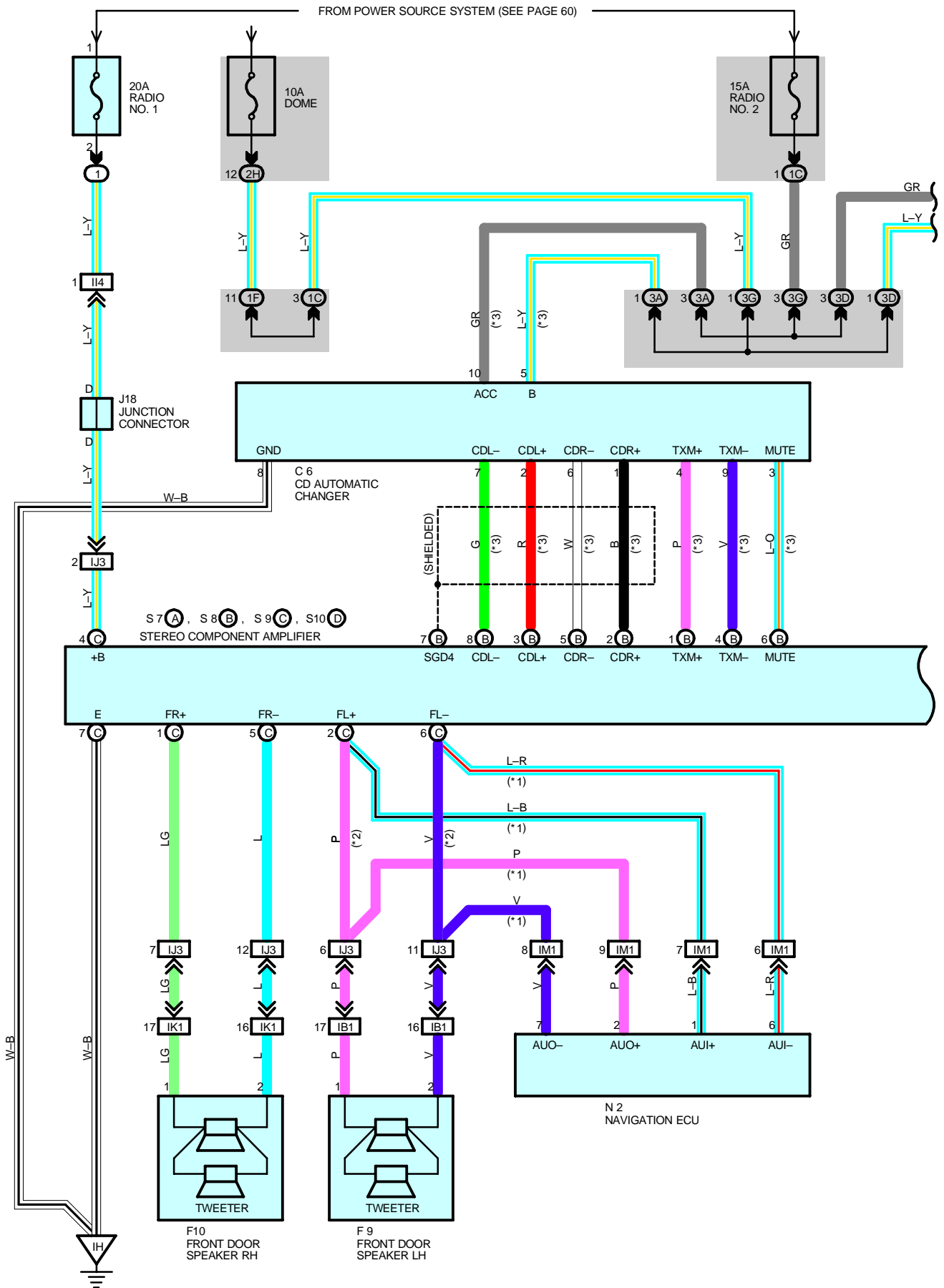

- * 1 : W/ LEXUS NAVIGATION SYSTEM
- * 2 : W/O LEXUS NAVIGATION SYSTEM
- * 3 : W/ CD AUTOMATIC CHANGER
- * 4 : W/ AUTO ANTENNA

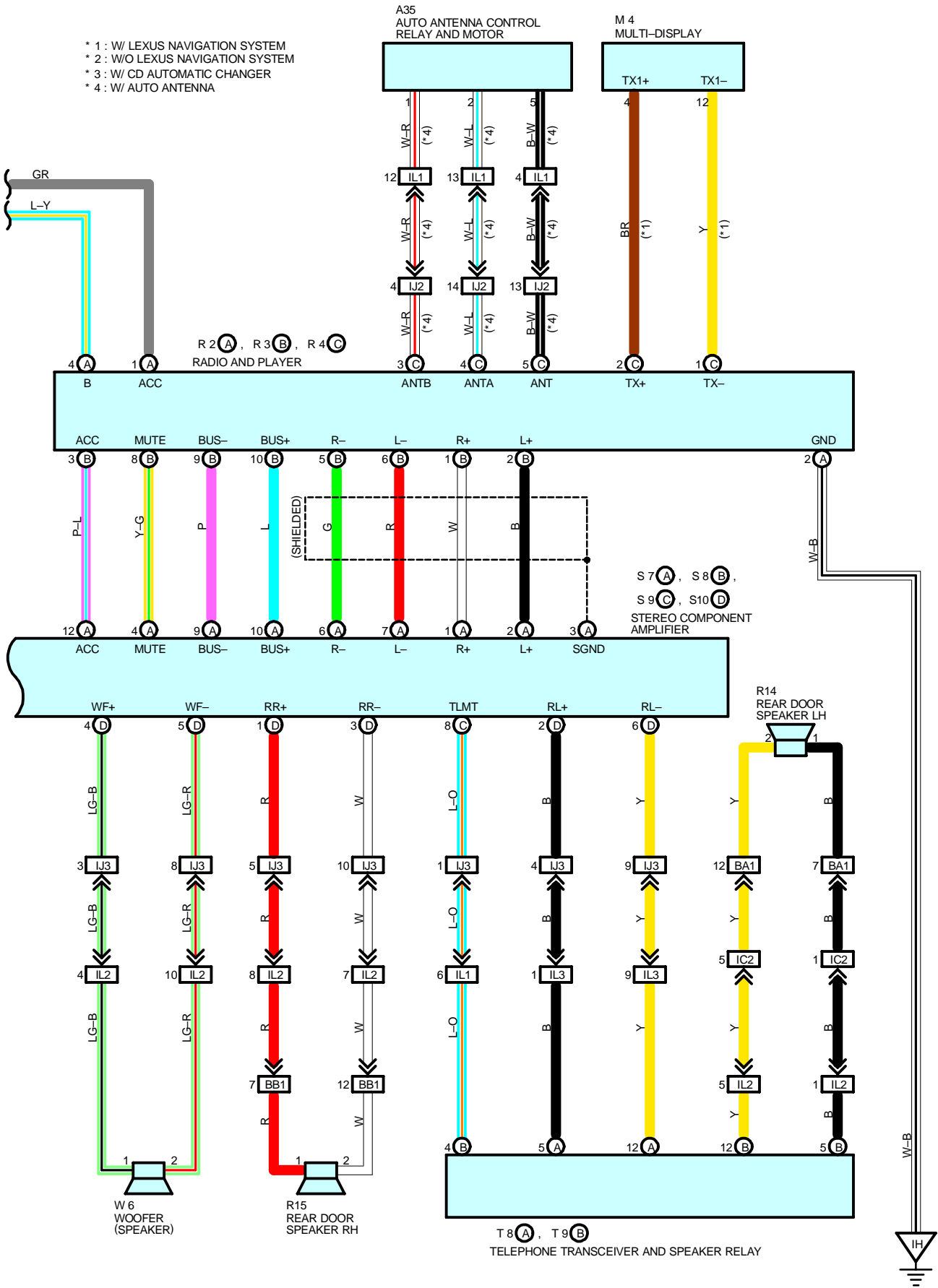

RADIO AND PLAYER (EXCEPT NAKAMICHI)

SERVICE HINTS

R2 (A) RADIO AND PLAYER

- (A) 1-GROUND : Approx. 12 volts with ignition SW at **ACC** or **ON** position
- (A) 4-GROUND : Always approx. 12 volts
- (A) 2-GROUND : Always continuity

S9 (C) STEREO COMPONENT AMPLIFIER

- (C) 4-GROUND : Always approx. 12 volts
- (C) 7-GROUND : Always continuity

C6 CD AUTOMATIC CHANGER

- 5-GROUND : Always approx. 12 volts
- 10-GROUND : Approx. 12 volts with ignition SW at **ACC** or **ON** position
- 8-GROUND : Always continuity

○ : PARTS LOCATION

Code	See Page	Code	See Page	Code	See Page
A35	42	R2	A 41	S9	C 41
C6	40	R3	B 41	S10	D 41
F9	42	R4	C 41	T8	A 43
F10	42	R14	43	T9	B 43
J18	41	R15	43	W6	43
M4	41	S7	A 41		
N2	43	S8	B 41		

○ : RELAY BLOCKS

Code	See Page	Relay Blocks (Relay Block Location)
1	22	Engine Room No.1 R/B (Engine Compartment Right)

○ : JUNCTION BLOCK AND WIRE HARNESS CONNECTOR

Code	See Page	Junction Block and Wire Harness (Connector Location)
1C	26	Instrument Panel Wire and Driver Side J/B (Left Kick Panel)
1F	26	Cowl Wire and Driver Side J/B (Left Kick Panel)
2H	29	Cowl Wire and Passenger Side J/B (Right Kick Panel)
3A	30	Instrument Panel Wire and Instrument Panel J/B (Instrument Panel Reinforcement Center)
3D		
3G		

□ : CONNECTOR JOINING WIRE HARNESS AND WIRE HARNESS

Code	See Page	Joining Wire Harness and Wire Harness (Connector Location)
IB1	50	Front Door LH Wire and Cowl Wire (Left Kick Panel)
IC2	50	Floor No.2 Wire and Cowl Wire (Left Kick Panel)
II4	52	Engine Room Main Wire and Cowl Wire (Near the Passenger Side R/B)
IJ2	52	Instrument Panel Wire and Cowl Wire (Left Side of the Blower Unit)
IJ3		
IK1	52	Front Door RH Wire and Cowl Wire (Right Kick Panel)
IL1	52	Floor No.1 Wire and Cowl Wire (Right Kick Panel)
IL2		
IL3		
IM1	52	Instrument Panel Wire and Floor No.1 Wire (Front RH Side of the Shift Lever)
BA1	54	Rear Door LH Wire and Floor No.2 Wire (Under the Center Pillar LH)
BB1	54	Rear Door RH Wire and Floor No.1 Wire (Under the Center Pillar RH)

▽ : GROUND POINTS

Code	See Page	Ground Points Location
IH	50	Instrument Panel Brace RH

A35

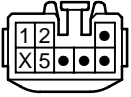

C6

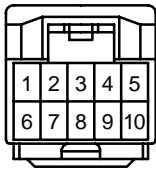

F9



F10



J18
BLUE

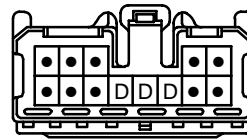

(Hint : See Page 7)

M4

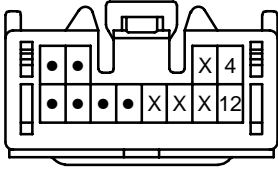

N2

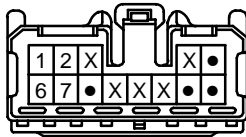

R2 (A)

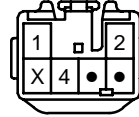

R3 (B)

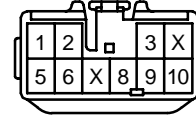

R4 (C)

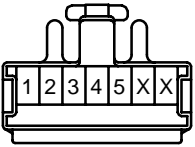

R14



R15



S7 (A)
BLACK

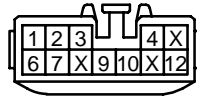

S8 (B)
ORANGE



S9 (C)

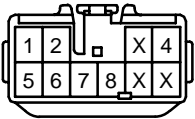

S10 (D)

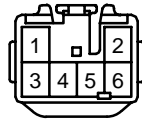

T8 (A)

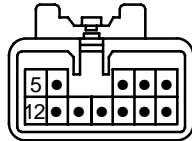

T9 (B)

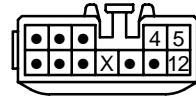

W6

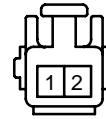

RADIO AND PLAYER (NAKAMICHI)

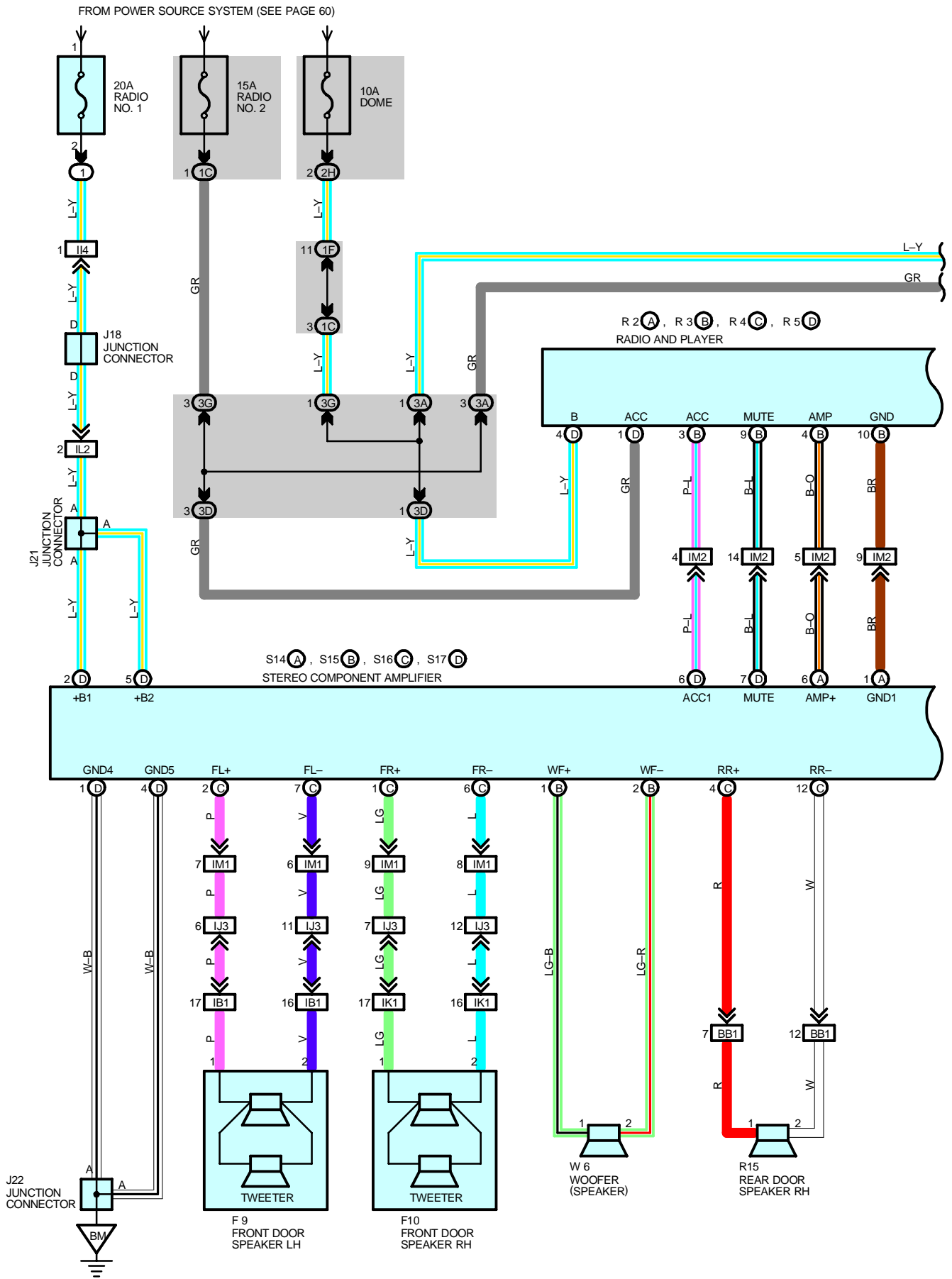

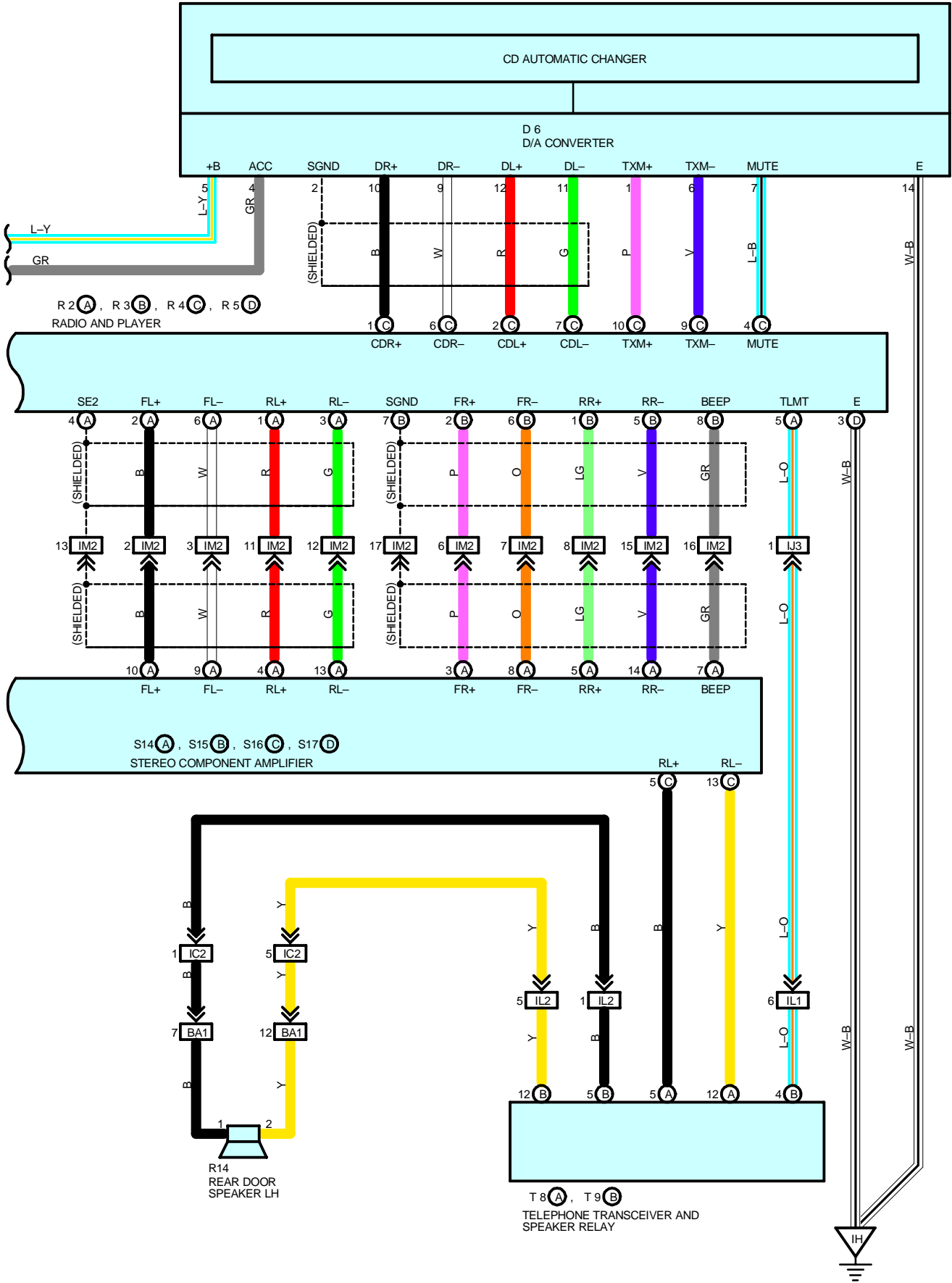

RADIO AND PLAYER (NAKAMICHI)

SERVICE HINTS

R5 (D) RADIO AND PLAYER

(D) 1-GROUND : Approx. 12 volts with ignition SW at **ACC** or **ON** position

(D) 4-GROUND : Always approx. 12 volts

(D) 3-GROUND : Always continuity

S17 (D) STEREO COMPONENT AMPLIFIER

(D) 2, (D) 5-GROUND : Always approx. 12 volts

(D) 1, (D) 4-GROUND : Always continuity

D6 D/A CONVERTER

4-GROUND : Approx. 12 volts with ignition SW at **ACC** or **ON** position

5-GROUND : Always approx. 12 volts

○ : PARTS LOCATION

Code	See Page	Code	See Page	Code	See Page
D 6	40	R3	B 41	S16	C 43
F9	42	R4	C 41	S17	D 43
F10	42	R5	D 41	T8	A 43
J18	41	R14	43	T9	B 43
J21	42	R15	43	W6	43
J22	42	S14	A 43		
R2	A 41	S15	B 43		

○ : RELAY BLOCKS

Code	See Page	Relay Blocks (Relay Block Location)
1	22	Engine Room No.1 R/B (Engine Compartment Right)

○ : JUNCTION BLOCK AND WIRE HARNESS CONNECTOR

Code	See Page	Junction Block and Wire Harness (Connector Location)
1C	26	Instrument Panel Wire and Driver Side J/B (Left Kick Panel)
1F	26	Cowl Wire and Driver Side J/B (Left Kick Panel)
2H	29	Cowl Wire and Passenger Side J/B (Right Kick Panel)
3A	30	Instrument Panel Wire and Instrument Panel J/B (Instrument Panel Reinforcement Center)
3D		
3G	31	

□ : CONNECTOR JOINING WIRE HARNESS AND WIRE HARNESS

Code	See Page	Joining Wire Harness and Wire Harness (Connector Location)
IB1	50	Front Door LH Wire and Cowl Wire (Left Kick Panel)
IC2	50	Floor No.2 Wire and Cowl Wire (Left Kick Panel)
II4	52	Engine Room Main Wire and Cowl Wire (Near the Passenger Side R/B)
IJ3	52	Instrument Panel Wire and Cowl Wire (Left Side of the Blower Unit)
IK1	52	Front Door RH Wire and Cowl Wire (Right Kick Panel)
IL1	52	Floor No.1 Wire and Cowl Wire (Right Kick Panel)
IL2		
IM1	52	Instrument Panel Wire and Floor No.1 Wire (Front RH Side of the Shift Lever)
IM2		
BA1	54	Rear Door LH Wire and Floor No.2 Wire (Under the Center Pillar LH)
BB1	54	Rear Door RH Wire and Floor No.1 Wire (Under the Center Pillar RH)

▽ : GROUND POINTS

Code	See Page	Ground Points Location
IH	50	Instrument Panel Brace RH
BM	54	Quarter Panel RH

D6

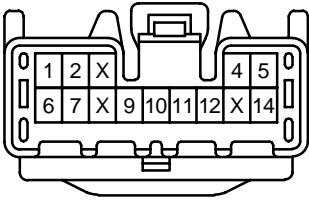

F9



F10



J18
BLUE

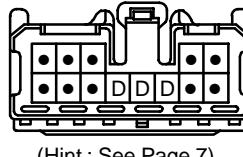

(Hint : See Page 7)

J21
BLACK



(Hint : See Page 7)

J22

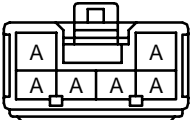

(Hint : See Page 7)

R2 (A)

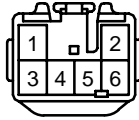

R3 (B)

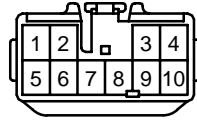

R4 (C)

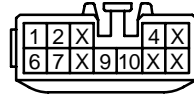

R5 (D)
ORANGE

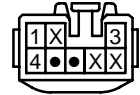

R14



R15



S14 (A)

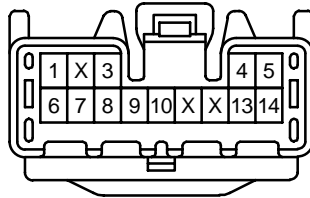

S15 (B)
GRAY

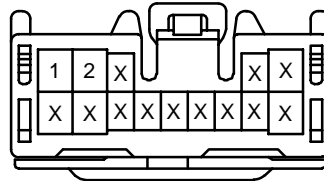

S16 (C)
GREEN

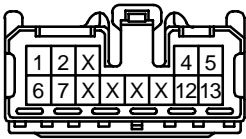

S17 (D)
ORANGE

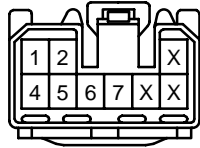

T8 (A)

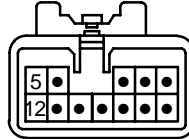

T9 (B)

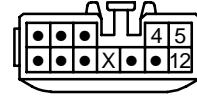

W6

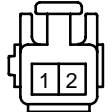

REAR WINDOW DEFOGGER AND MIRROR HEATER

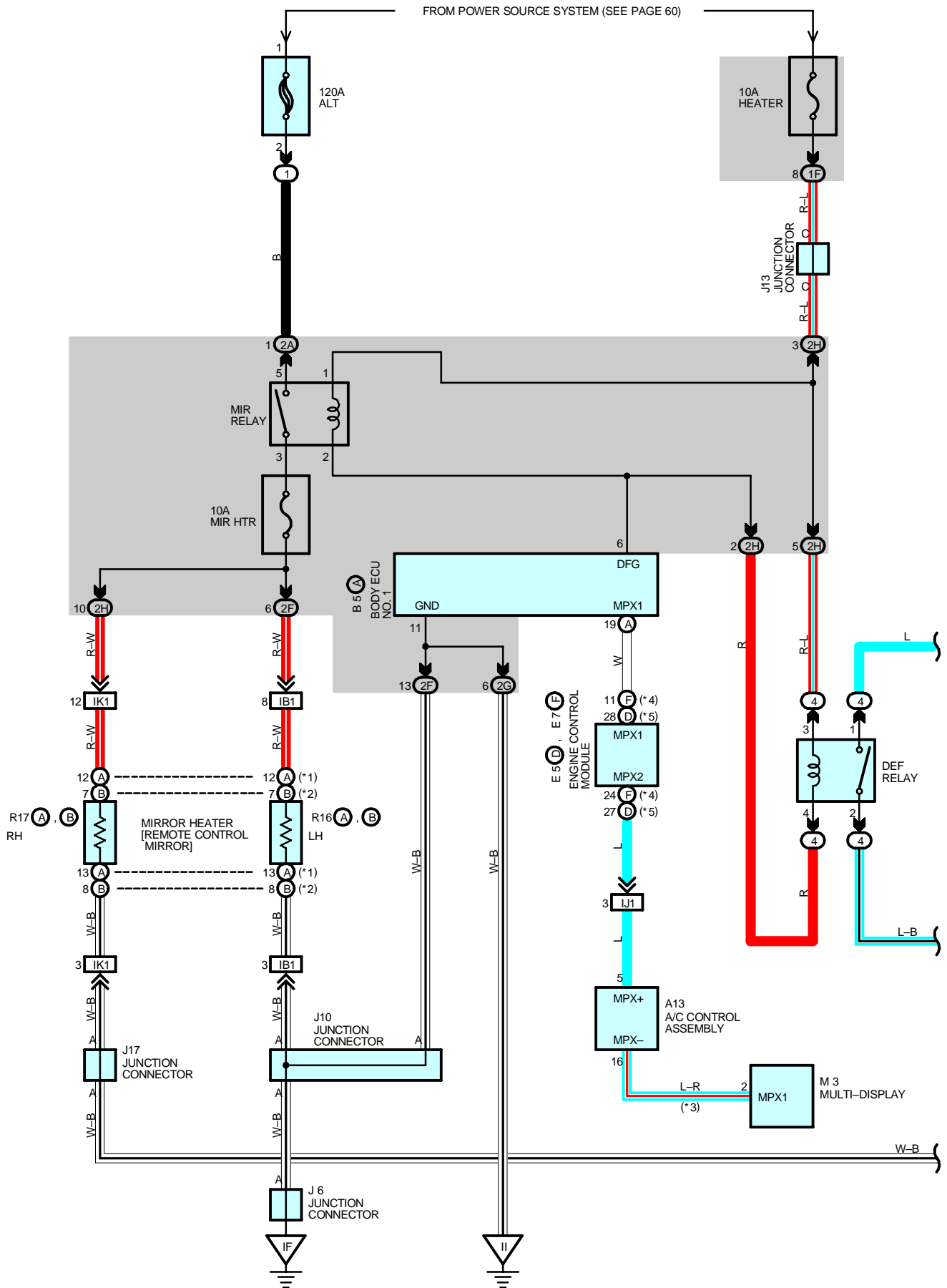

FROM POWER SOURCE SYSTEM (SEE PAGE 60)

- * 1 : W/ DRIVING POSITION MEMORY
- * 2 : W/O DRIVING POSITION MEMORY
- * 3 : W/ LEXUS NAVIGATION SYSTEM
- * 4 : 1UZ-FE
- * 5 : 2JZ-GE

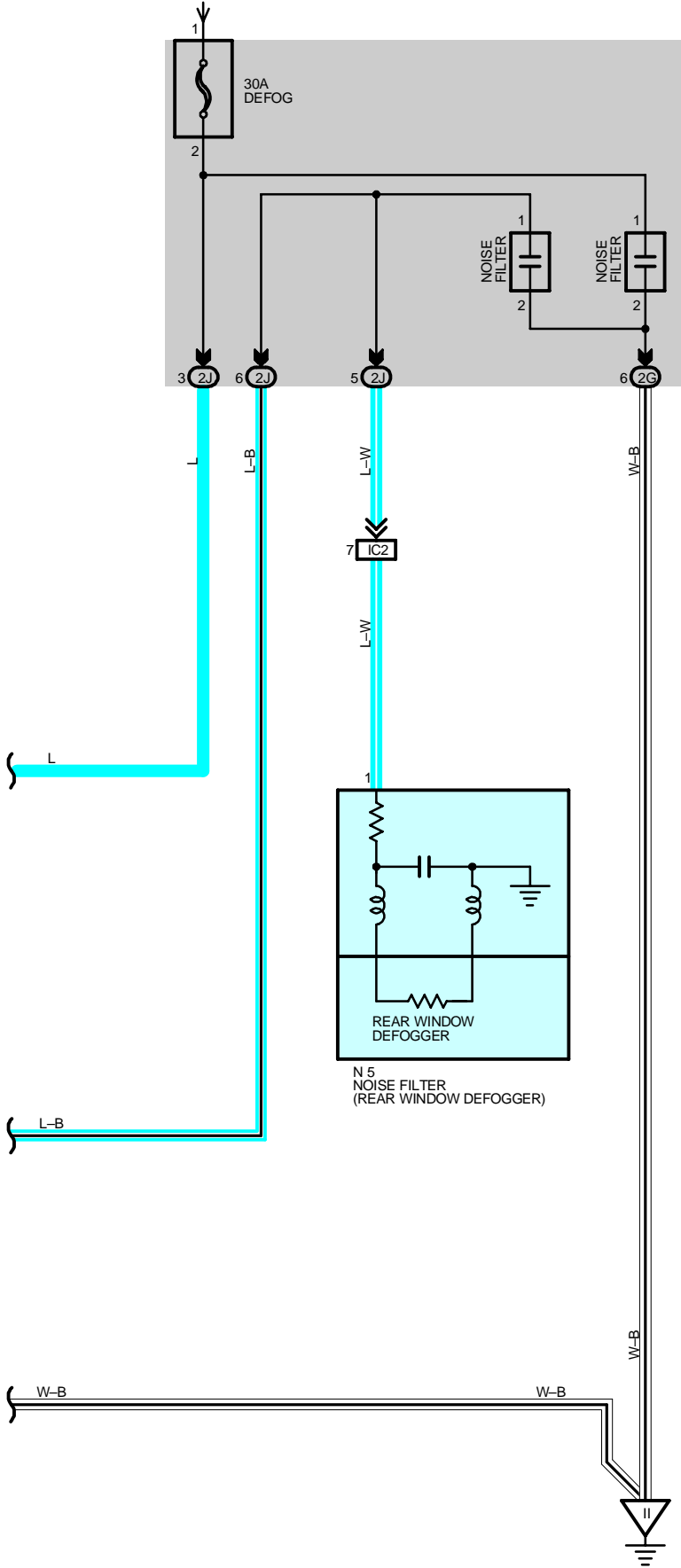

REAR WINDOW DEFOGGER AND MIRROR HEATER

SERVICE HINTS

DEF RELAY

1-2 : Closed with ignition SW at **ON** position and defogger SW on

○ : PARTS LOCATION

Code	See Page	Code	See Page	Code	See Page
A13	40	J10	41	R16	A 43
B5	A 40	J13	41		B 43
E5	D 38 (2JZ-GE)	J17	41	R17	A 43
E7	F 36 (1UZ-FE)	M3	41		B 43
J6	41	N5	43		

○ : RELAY BLOCKS

Code	See Page	Relay Blocks (Relay Block Location)
1	22	Engine Room No.1 R/B (Engine Compartment Right)
4	25	Passenger Side R/B (Right Kick Panel)

○ : JUNCTION BLOCK AND WIRE HARNESS CONNECTOR

Code	See Page	Junction Block and Wire Harness (Connector Location)
1F	26	Cowl Wire and Driver Side J/B (Left Kick Panel)
2A	28	Engine Room Main Wire and Passenger Side J/B (Right Kick Panel)
2F	28	Cowl Wire and Passenger Side J/B (Right Kick Panel)
2G	29	
2H		
2J		

□ : CONNECTOR JOINING WIRE HARNESS AND WIRE HARNESS

Code	See Page	Joining Wire Harness and Wire Harness (Connector Location)
IB1	50	Front Door LH Wire and Cowl Wire (Left Kick Panel)
IC2	50	Floor No.2 Wire and Cowl Wire (Left Kick Panel)
IJ1	52	Instrument Panel Wire and Cowl Wire (Left Side of the Blower Unit)
IK1	52	Front Door RH Wire and Cowl Wire (Right Kick Panel)

▽ : GROUND POINTS

Code	See Page	Ground Points Location
IF	50	Left Kick Panel
II	50	Right Side of the Cowl Panel

A13

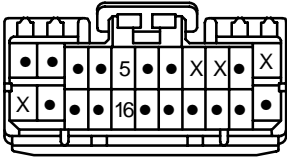

B5 (A)

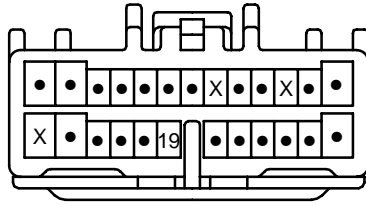

E5 (D)
(2JZ-GE)

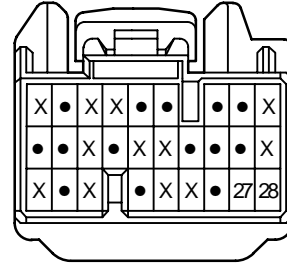

E7 (F)
(1UZ-FE)

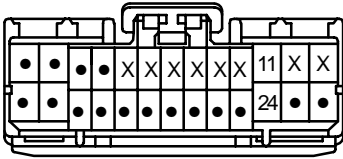

J6

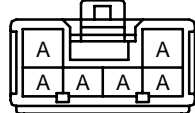

(Hint : See Page 7)

J10
ORANGE

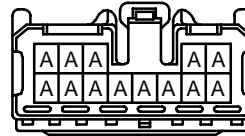

(Hint : See Page 7)

J13

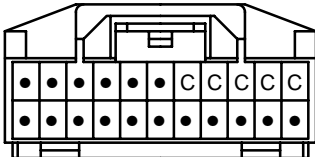

(Hint : See Page 7)

J17



(Hint : See Page 7)

M3
BLUE

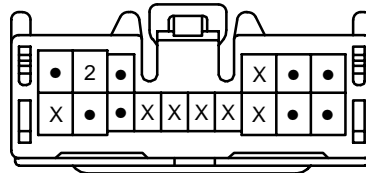

N5



R16 (A)

(w/ Driving Position Memory)

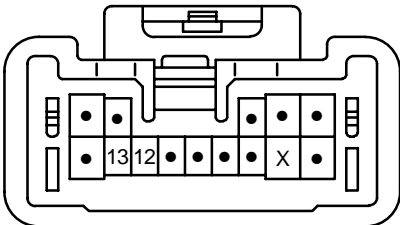

R16 (B)

(w/o Driving Position Memory)



R17 (A)

(w/ Driving Position Memory)

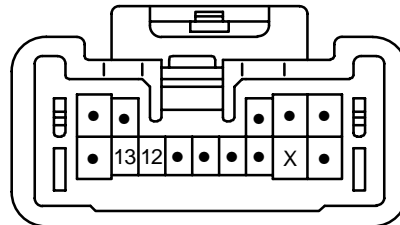

R17 (B)

(w/o Driving Position Memory)



REMOTE CONTROL MIRROR

FROM POWER SOURCE SYSTEM (SEE PAGE 60)

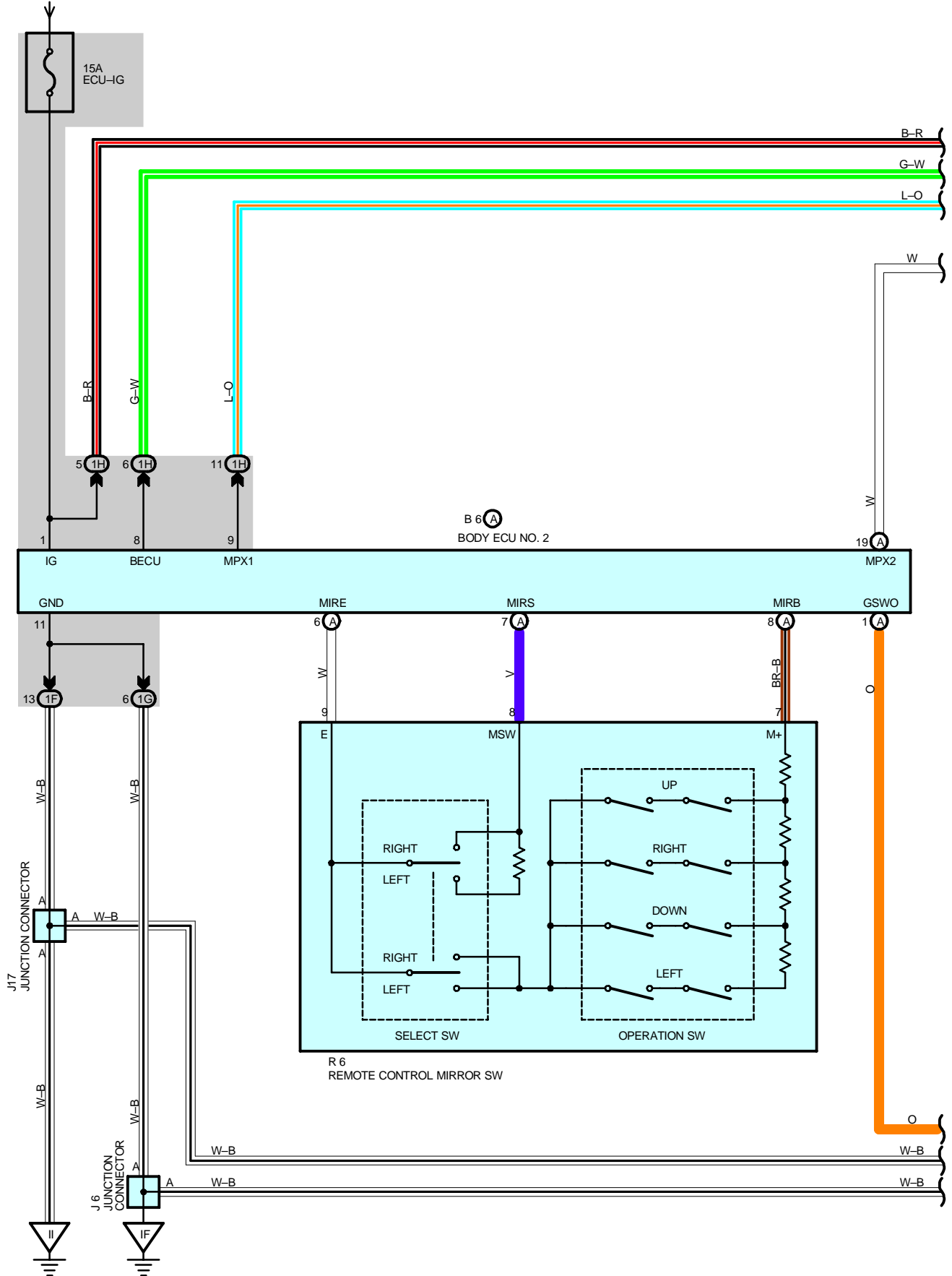

FROM POWER SOURCE SYSTEM (SEE PAGE 60)

- * 1 : W/ LEXUS NAVIGATION SYSTEM
- * 2 : W/O LEXUS NAVIGATION SYSTEM
- * 3 : 1UZ-FE
- * 4 : 2JZ-GE

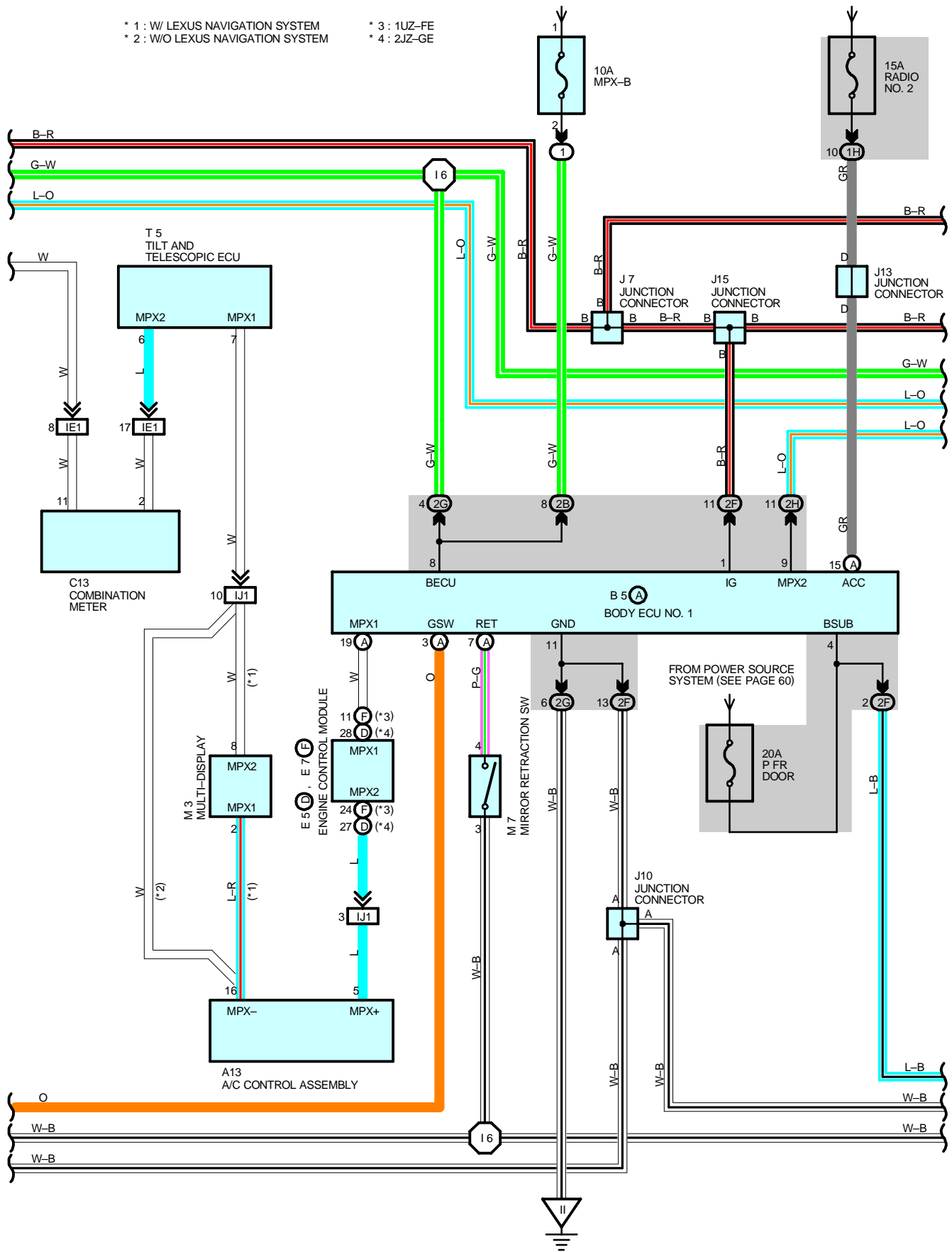

REMOTE CONTROL MIRROR

FROM POWER SOURCE SYSTEM (SEE PAGE 60)

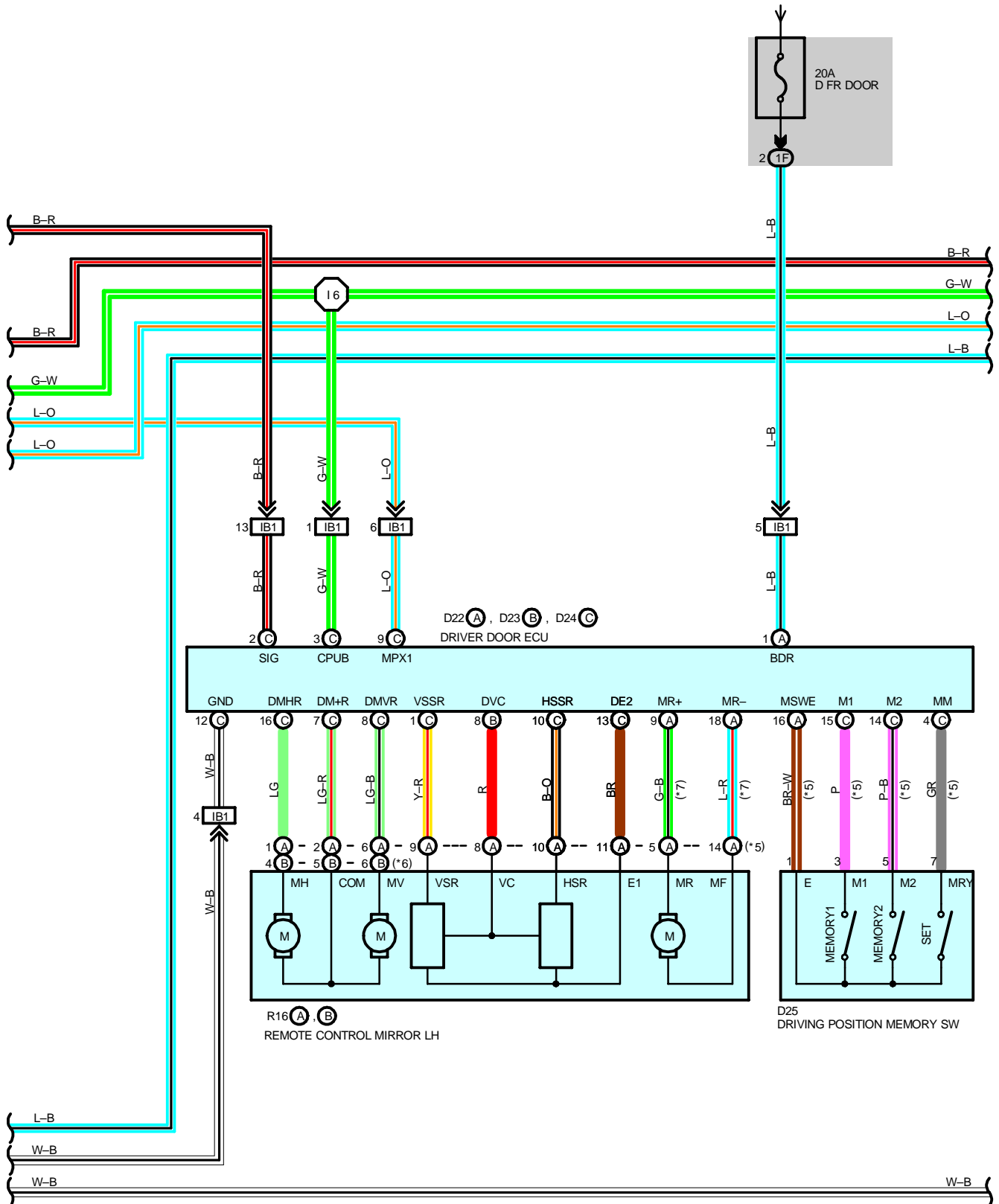

- * 5 : W/ DRIVING POSITION MEMORY
- * 6 : W/O DRIVING POSITION MEMORY
- * 7 : W/ RETRACTION

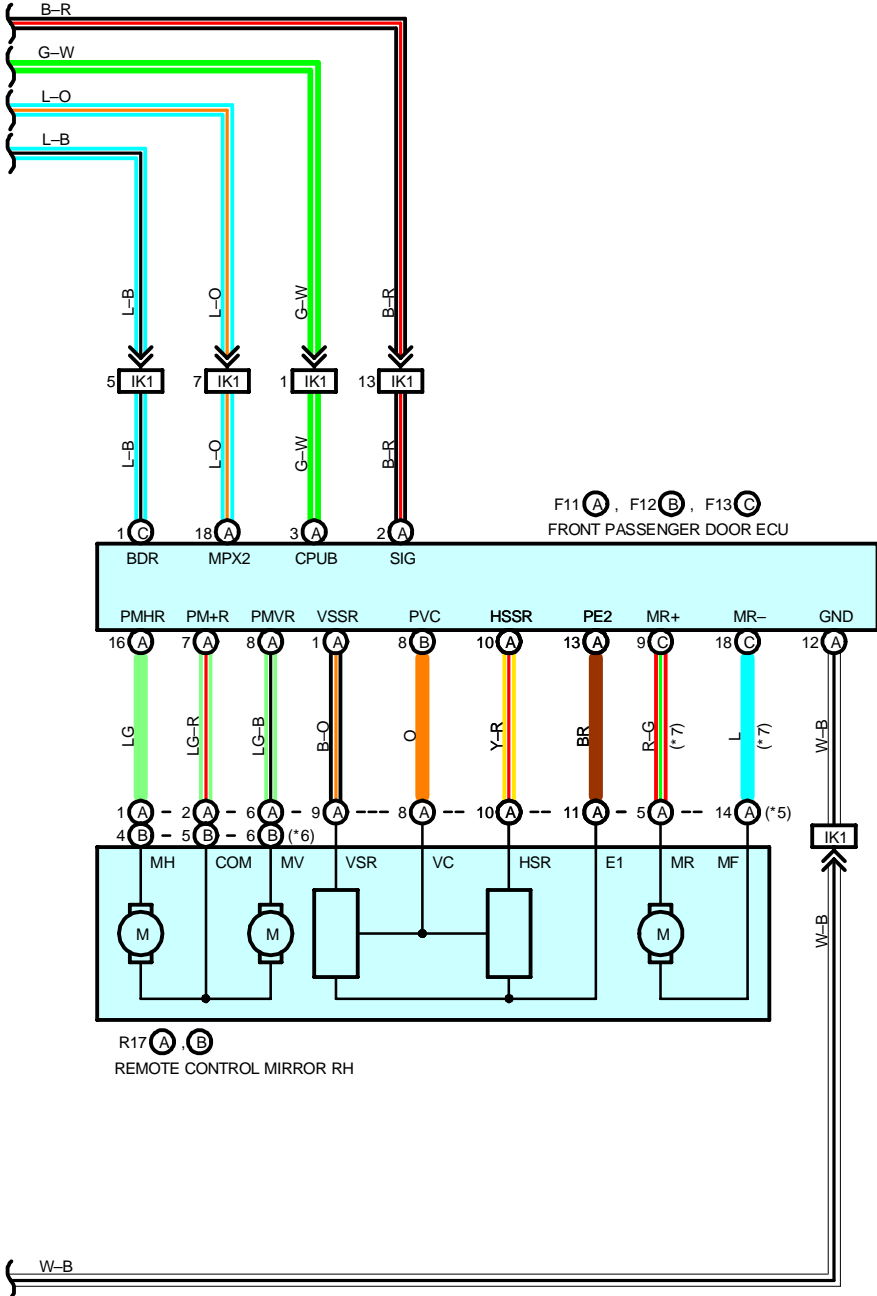

REMOTE CONTROL MIRROR

SYSTEM OUTLINE

REMOTE CONTROL MIRROR OPERATION

When the ignition SW is turned to the ACC or ON position, the outer mirrors can be operated. When the remote control mirror SW is operated, the signal is input to body ECU No.2 and the outer mirror is adjusted to the desired position through communication control of the body ECU and door ECU etc.

In the remote control mirror system, the position sensor detects the number of rotations of each motor (Movement amount of each mirror) and inputs it to the ECU. This makes it possible to store and recall the outer mirror position using the position memory SW. The outer mirror position is stored and recalled through communication control of the body ECU and door ECU etc.

SERVICE HINTS

R6 REMOTE CONTROL MIRROR SW

- 8-9 : Continuity with select SW at right side
Approx. **100** Ω with select SW at left side
- 7-9 : Approx. **100** Ω with operation SW at up side
Approx. **250** Ω with operation SW at right side
Approx. **470** Ω with operation SW at down side
Approx. **800** Ω with operation SW at left side

○ : PARTS LOCATION

Code	See Page	Code	See Page	Code	See Page	
A13	40	E7	F	36 (1UZ-FE)	J17	41
B5	A 40	F11	A	42	M3	41
B6	A 40	F12	B	42	M7	41
C13	40	F13	C	42	R6	41
D22	A 42	J6		41	R16	A 43
D23	B 42	J7		41		B 43
D24	C 42	J10		41	R17	A 43
D25	42	J13		41		B 43
E5	D 38 (2JZ-GE)	J15		41	T5	41

○ : RELAY BLOCKS

Code	See Page	Relay Blocks (Relay Block Location)
1	22	Engine Room No.1 R/B (Engine Compartment Right)

○ : JUNCTION BLOCK AND WIRE HARNESS CONNECTOR

Code	See Page	Junction Block and Wire Harness (Connector Location)
1F	26	Cowl Wire and Driver Side J/B (Left Kick Panel)
1G	27	
1H		
2B	28	Engine Room Main Wire and Passenger Side J/B (Right Kick Panel)
2F	28	Cowl Wire and Passenger Side J/B (Right Kick Panel)
2G	29	
2H		

□ : CONNECTOR JOINING WIRE HARNESS AND WIRE HARNESS

Code	See Page	Joining Wire Harness and Wire Harness (Connector Location)
IB1	50	Front Door LH Wire and Cowl Wire (Left Kick Panel)
IE1	50	Instrument Panel Wire and Cowl Wire (Left Side of the Steering Column)
IJ1	52	Instrument Panel Wire and Cowl Wire (Left Side of the Blower Unit)
IK1	52	Front Door RH Wire and Cowl Wire (Right Kick Panel)



: GROUND POINTS

Code	See Page	Ground Points Location
IF	50	Left Kick Panel
II	50	Right Side of the Cowl Panel



: SPLICE POINTS

Code	See Page	Wire Harness with Splice Points	Code	See Page	Wire Harness with Splice Points
I 6	52	Cowl Wire			

A13

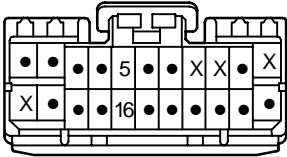

B5 (A)

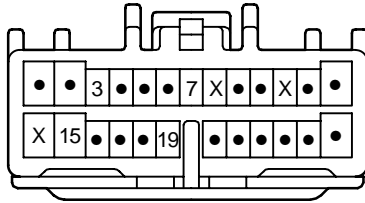

B6 (A)

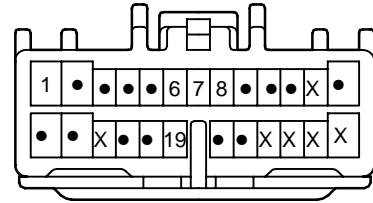

C13

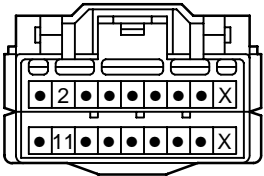

D22 (A)
GRAY

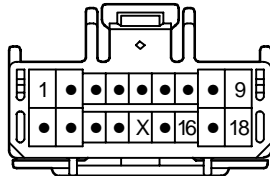

D23 (B)
GRAY

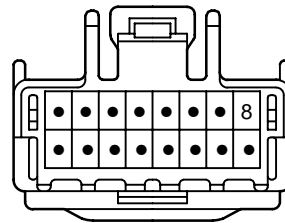

D24 (C)
GRAY

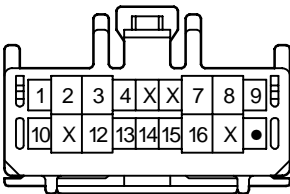

D25
BLUE

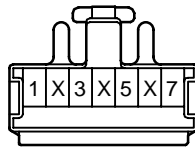

E5 (D)
(2JZ-GE)

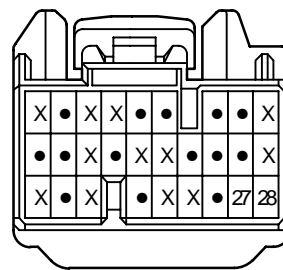

E7 (F)
(1UZ-FE)

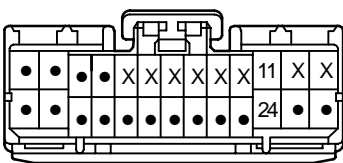

F11 (A)
GRAY

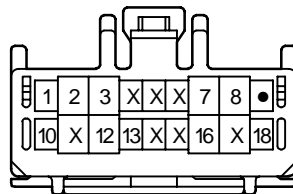

F12 (B)
GRAY

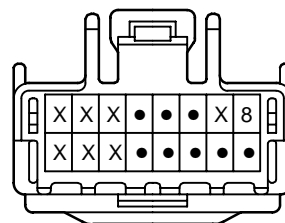

REMOTE CONTROL MIRROR

F13 (C)
GRAY

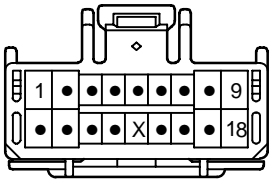

J6

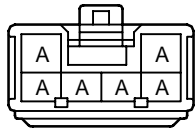

(Hint : See Page 7)

J7
GRAY

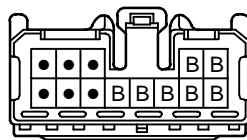

(Hint : See Page 7)

J10
ORANGE

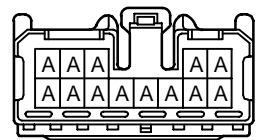

(Hint : See Page 7)

J13

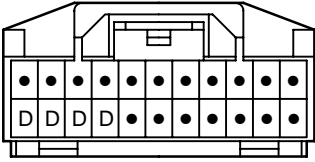

(Hint : See Page 7)

J15

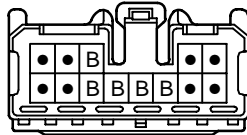

(Hint : See Page 7)

J17

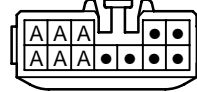

(Hint : See Page 7)

M3
BLUE

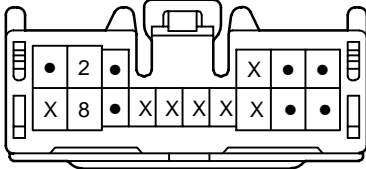

M7
DARK GRAY

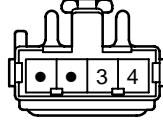

R6
BLACK

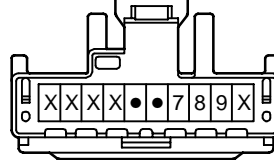

R16 (A)

(w/ Driving Position Memory)

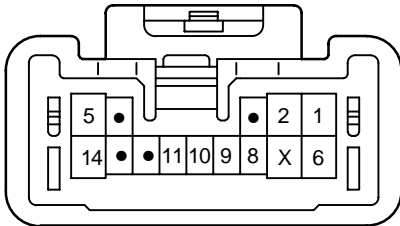

R16 (B)

(w/o Driving Position Memory)

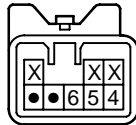

R17 (A)

(w/ Driving Position Memory)

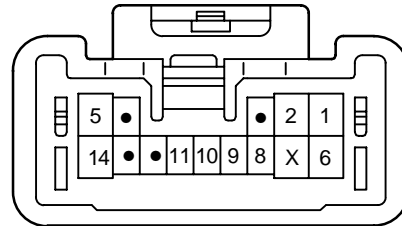

R17 (B)

(w/o Driving Position Memory)



T5
GRAY

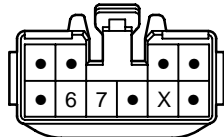

SEAT HEATER

FROM POWER SOURCE SYSTEM (SEE PAGE 60)

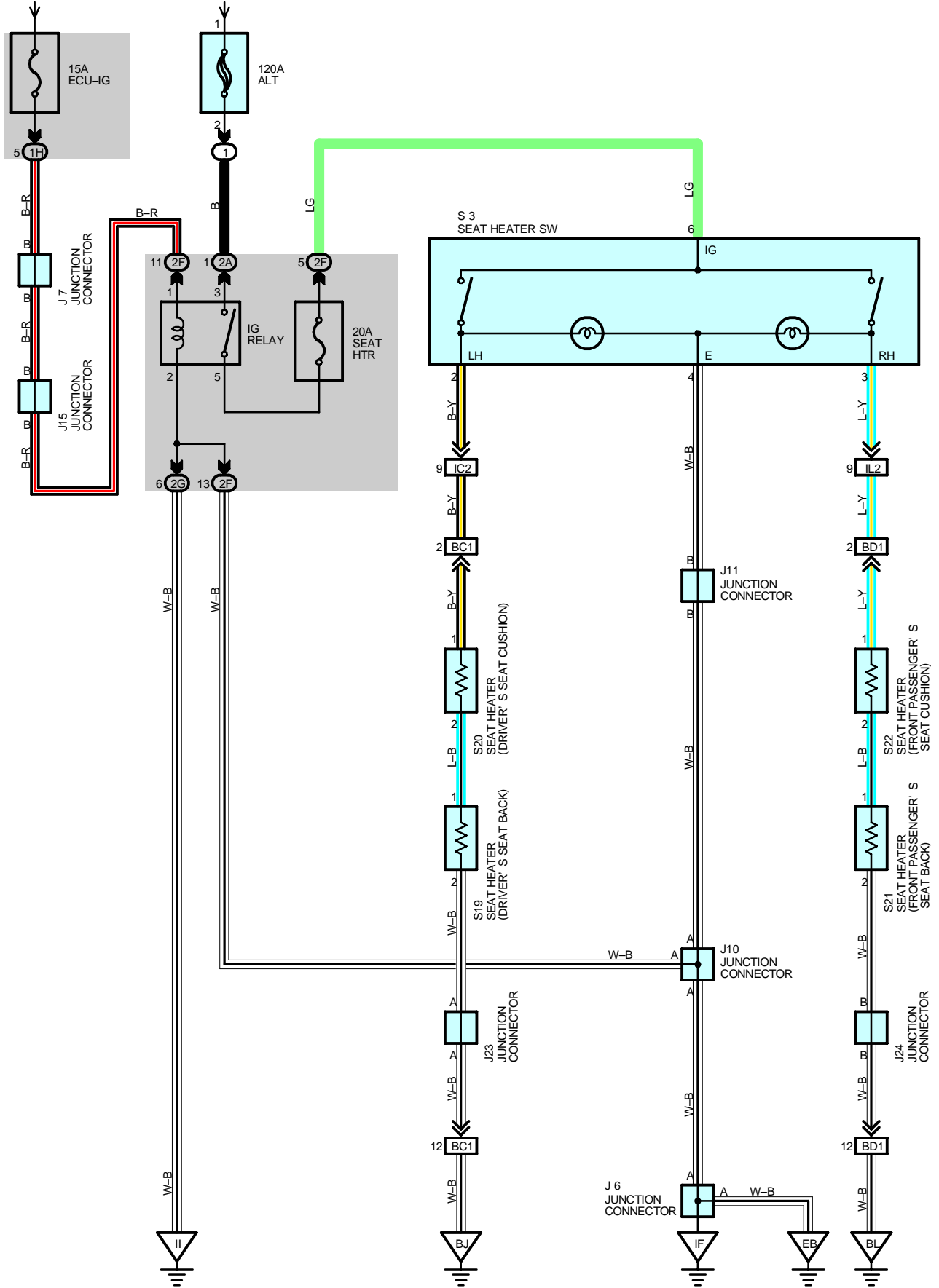

SERVICE HINTS**S3 SEAT HEATER SW**6-GROUND : Approx. 12 volts with ignition SW at **ON** or **ST** position

4-GROUND : Always continuity

○ : PARTS LOCATION

Code	See Page	Code	See Page	Code	See Page
J6	41	J15	41	S19	44
J7	41	J23	44	S20	44
J10	41	J24	44	S21	44
J11	41	S3	41	S22	44

○ : RELAY BLOCKS

Code	See Page	Relay Blocks (Relay Block Location)
1	22	Engine Room No.1 R/B (Engine Compartment Right)

○ : JUNCTION BLOCK AND WIRE HARNESS CONNECTOR

Code	See Page	Junction Block and Wire Harness (Connector Location)
1H	27	Cowl Wire and Driver Side J/B (Left Kick Panel)
2A	28	Engine Room Main Wire and Passenger Side J/B (Right Kick Panel)
2F	28	Cowl Wire and Passenger Side J/B (Right Kick Panel)
2G	29	

□ : CONNECTOR JOINING WIRE HARNESS AND WIRE HARNESS

Code	See Page	Joining Wire Harness and Wire Harness (Connector Location)
IC2	50	Floor No.2 Wire and Cowl Wire (Left Kick Panel)
IL2	52	Floor No.1 Wire and Cowl Wire (Right Kick Panel)
BC1	56	Floor No.2 Wire and Front Seat LH Wire (Under the Driver's Seat)
BD1	56	Floor No.1 Wire and Front Seat RH Wire (Under the Front Passenger's Seat)

▽ : GROUND POINTS

Code	See Page	Ground Points Location
EB	46 (1UZ-FE)	Left Fender
	48 (2JZ-GE)	
IF	50	Left Kick Panel
II	50	Right Side of the Cowl Panel
BJ	54	Rear Floor Partition Panel LH
BL	54	Rear Floor Partition Panel RH

SEAT HEATER

J6

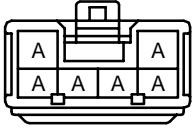

(Hint : See Page 7)

J7
GRAY

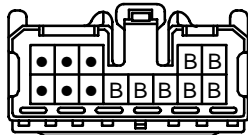

(Hint : See Page 7)

J10
ORANGE

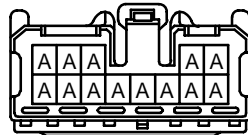

(Hint : See Page 7)

J11
GRAY

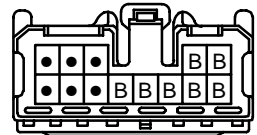

(Hint : See Page 7)

J15

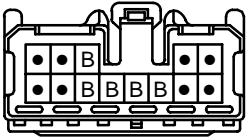

(Hint : See Page 7)

J23



(Hint : See Page 7)

J24



(Hint : See Page 7)

S3

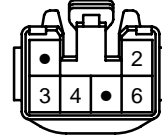

S19
GRAY



S20
GRAY

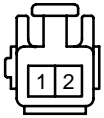

S21
GRAY

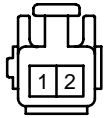

S22
GRAY

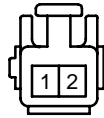

SHIFT LOCK

FROM POWER SOURCE SYSTEM (SEE PAGE 60)

* 1 : 1UZ-FE
* 2 : 2JZ-GE

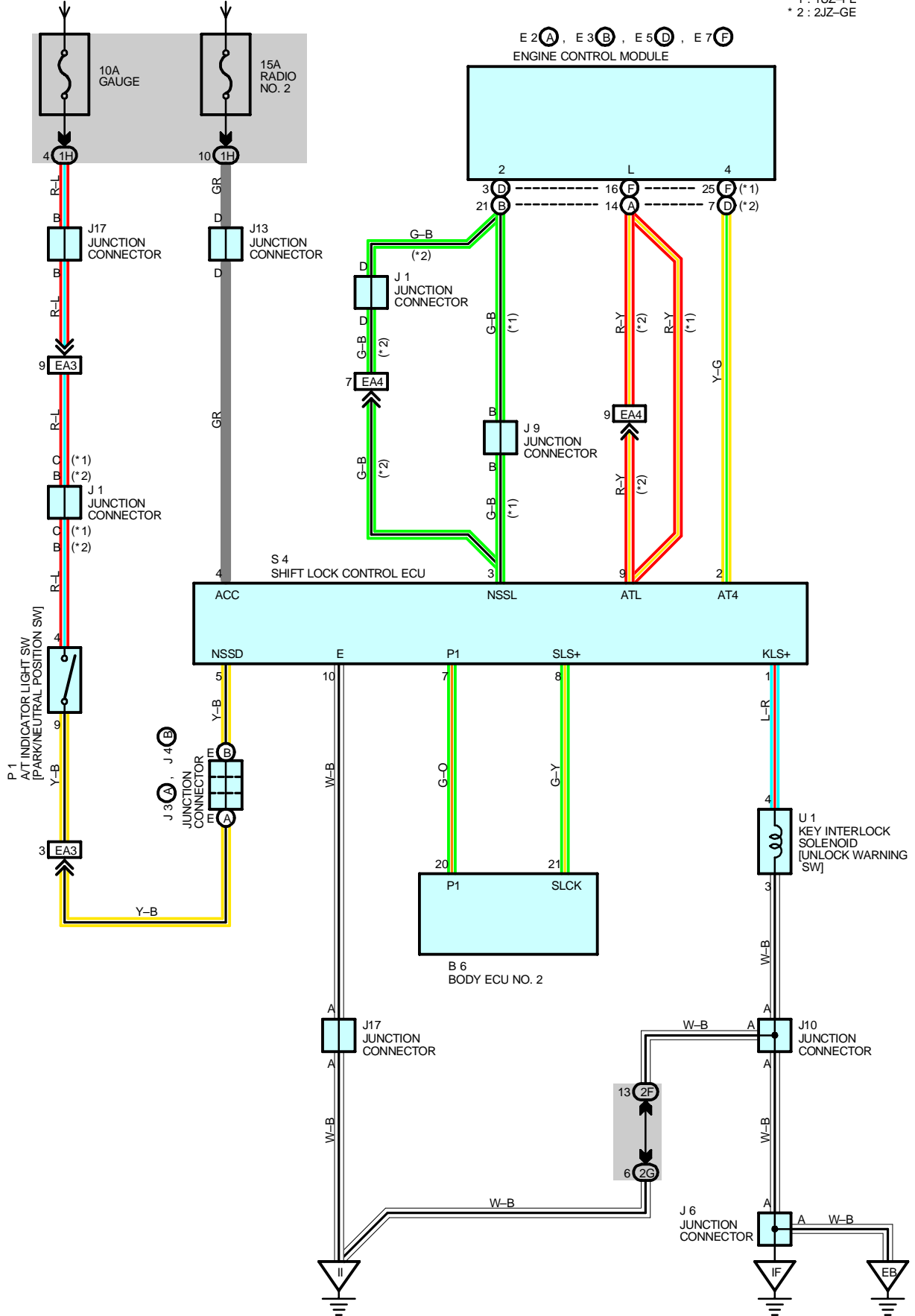

SYSTEM OUTLINE

1. SHIFT LOCK MECHANISM

If the brake pedal is depressed with the ignition SW set at ON (The stop light SW is on), the shift lock control ECU is activated, allowing the driver to change the shift lever to a position other than the P position.

2. REVERSE INHIBIT MECHANISM

Changing the shift lever to the R position is inhibited by operation of the shift lock control ECU and body ECU No.2 while the vehicle is travelling forward.

If the vehicle speed is almost 0 km/h, the signal is input to TERMINAL 8 of the shift lock control ECU through communication control of the body ECU and door ECU etc. , allowing the driver to change the shift lever to the R position.

3. KEY INTERLOCK MECHANISM

When the ignition SW is turned to the ACC or ON position and the shift lever is at a position other than the P position, the shift lock control ECU is activated to flow the current into the key interlock solenoid. This inhibits to turn the ignition SW from the ACC position to the OFF position.

SERVICE HINTS

S4 SHIFT LOCK CONTROL ECU

4-GROUND : Approx. 12 volts with ignition SW at **ACC** or **ON** position

10-GROUND : Always continuity

○ : PARTS LOCATION

Code	See Page	Code	See Page	Code	See Page
B6	40	J1	39 (2JZ-GE)	J10	41
E2	A	J3	A	J13	41
E3	B			39 (2JZ-GE)	J17
E5	D	J4	B	P1	37 (1UZ-FE)
					39 (2JZ-GE)
E7	F	J6	41	S4	41
J1	37 (1UZ-FE)	J9	41	U1	41

○ : JUNCTION BLOCK AND WIRE HARNESS CONNECTOR

Code	See Page	Junction Block and Wire Harness (Connector Location)
1H	27	Cowl Wire and Driver Side J/B (Left Kick Panel)
2F	28	Cowl Wire and Passenger Side J/B (Right Kick Panel)
2G	29	

□ : CONNECTOR JOINING WIRE HARNESS AND WIRE HARNESS

Code	See Page	Joining Wire Harness and Wire Harness (Connector Location)
EA3	46 (1UZ-FE)	Engine Wire and Cowl Wire (Inside of the ECU Box)
	48 (2JZ-GE)	
EA4	48 (2JZ-GE)	

▽ : GROUND POINTS

Code	See Page	Ground Points Location
EB	46 (1UZ-FE)	Left Fender
	48 (2JZ-GE)	
IF	50	Left Kick Panel
II	50	Right Side of the Cowl Panel

SHIFT LOCK

B6

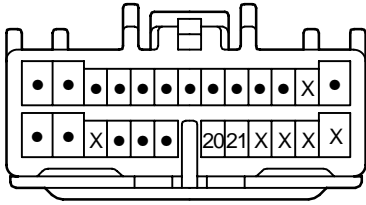

E2 (A)
(2JZ-GE)

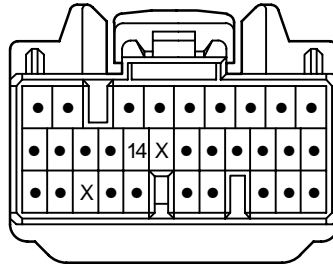

E3 (B)
(2JZ-GE)

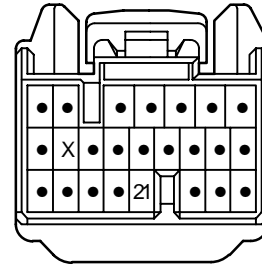

E5 (D)
(1UZ-FE)

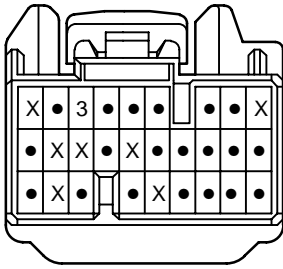

E5 (D)
(2JZ-GE)

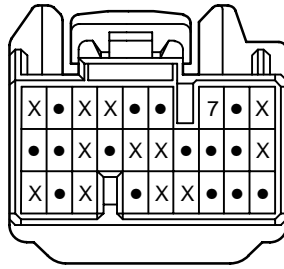

E7 (F)
(1UZ-FE)

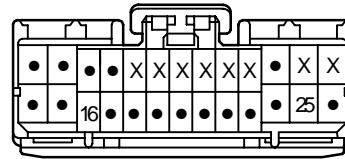

J1
(1UZ-FE) GRAY

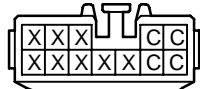

(Hint : See Page 7)

J1
(2JZ-GE) BLACK

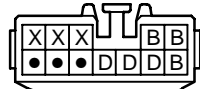

(Hint : See Page 7)

J3 (A)

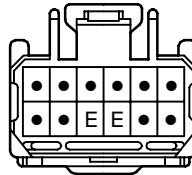

(Hint : See Page 7)

J4 (B)

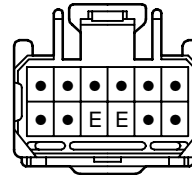

(Hint : See Page 7)

J6

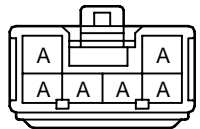

(Hint : See Page 7)

J9
(1UZ-FE)

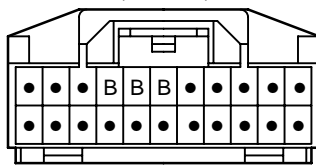

(Hint : See Page 7)

J10
ORANGE

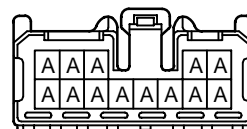

(Hint : See Page 7)

J13

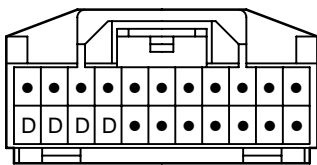

(Hint : See Page 7)

J17



(Hint : See Page 7)

P1
GRAY

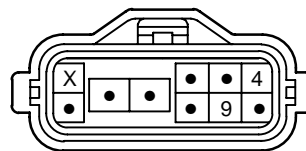

S4

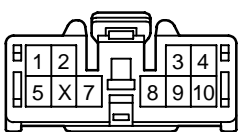

U1

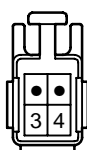

NOTICE: When inspecting or repairing the SRS, perform the operation in accordance with the following precautionary instructions and the procedure and precautions in the Repair Manual for the applicable model year.

- Malfunction symptoms of the SRS are difficult to confirm, so the DTCs become the most important source of information when troubleshooting. When troubleshooting the SRS, always inspect the DTCs before disconnecting the battery.
- **Work must be started after 90 seconds from when the ignition switch is turned to the "LOCK" position and the negative (-) terminal cable is disconnected from the battery.**
(The SRS is equipped with a back-up power source so that if work is started within 90 seconds from disconnecting the negative (-) terminal cable of the battery, the SRS may be deployed.)
- When the negative (-) terminal cable is disconnected from the battery, the memory of the clock and audio system will be canceled. So before starting work, make a record of the contents memorized in the audio memory system. When work is finished, reset the audio systems as they were before and adjust the clock. To avoid erasing the memory in each memory system, never use a back-up power supply from outside the vehicle.
- Before repairs, remove the airbag sensor if shocks are likely to be applied to the sensor during repairs.
- Do not expose the steering wheel pad, front passenger airbag assembly, side airbag assembly, seat belt pretensioner, center airbag sensor assembly, front airbag sensor or side airbag sensor assembly directly to hot air or flames.
- Even in cases of a minor collision where the SRS does not deploy, the steering wheel pad, front passenger airbag assembly, side airbag assembly, seat belt pretensioner, center airbag sensor assembly, front airbag sensor assembly and side airbag sensor assembly should be inspected.
- Never use SRS parts from another vehicle. When replacing parts, replace them with new parts.
- Never disassemble and repair the steering wheel pad, front passenger airbag assembly, side airbag assembly, seat belt pretensioner center airbag sensor assembly, front airbag sensor assembly or side airbag sensor assembly in order to reuse it.
- If the steering wheel pad, front passenger airbag assembly, side airbag assembly, seat belt pretensioner, center airbag sensor assembly, front airbag sensor assembly or side airbag sensor assembly has been dropped, or if there are cracks, dents or other defects in the case, bracket or connector, replace them with new ones.
- Use a volt/ohmmeter with high impedance (10 k Ω /V minimum) for troubleshooting the system's electrical circuits.
- Information labels are attached to the periphery of the SRS components. Follow the instructions on the notices.
- After work on the SRS is completed, perform the SRS warning light check or SRS side airbag warning light check.
- If the vehicle is equipped with a mobile communication system, refer to the precaution in the IN section of the Repair Manual.

SRS

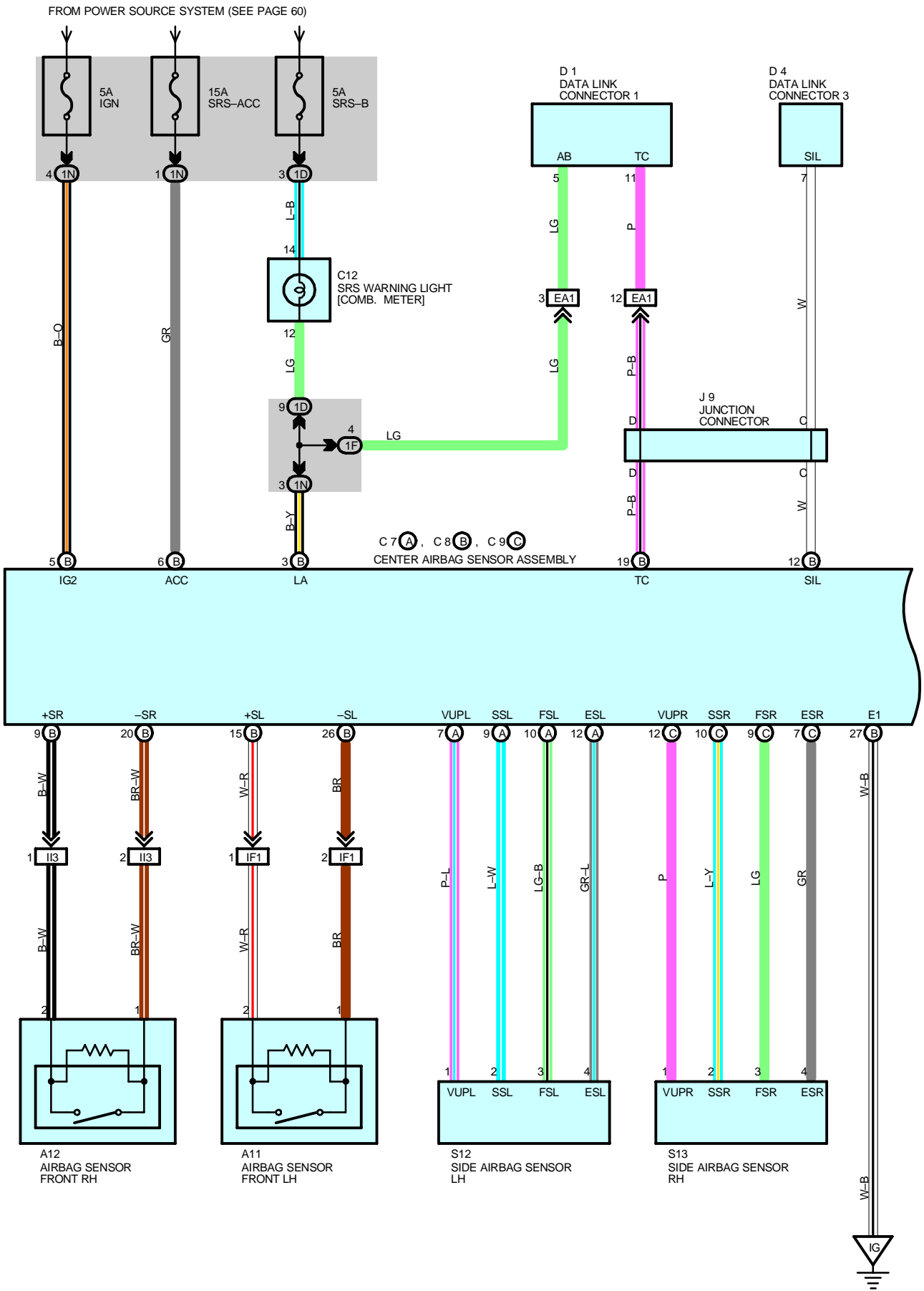

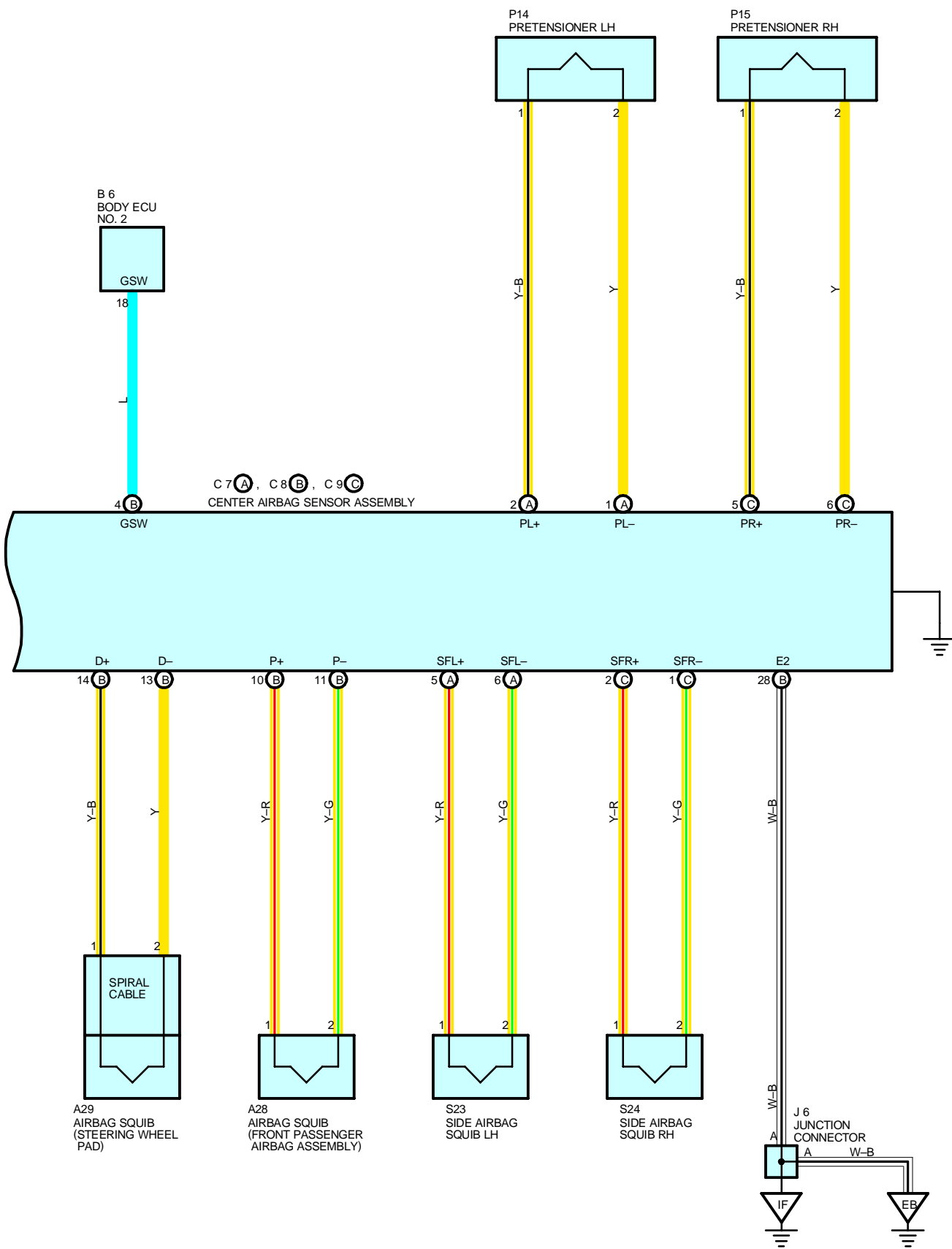

SYSTEM OUTLINE

The SRS is a driver and front passenger protection device which has a supplemental role to the seat belts. When the ignition SW is turned to ACC or ON, the current from the SRS-ACC fuse flows to TERMINAL (B) 6 of the center airbag sensor assembly. Only when the ignition SW is on does the current flow from the IGN fuse to TERMINAL (B) 5 of the center airbag sensor assembly.

If an accident occurs while driving, when the frontal impact exceeds a set level, the current from the SRS-ACC or IGN fuse flows to TERMINALS (B) 14, (B) 10, (C) 5 and (A) 2 of the center airbag sensor assembly to TERMINAL 1 of the airbag squibs and the pretensioners to TERMINAL 2 to TERMINALS (B) 13, (B) 11, (C) 6 and (A) 1 of the center airbag sensor assembly to TERMINAL (B) 27, (B) 28 or BODY GROUND to GROUND, so that current flows to the airbag squibs and the pretensioners and causes them to operate.

When the side impact also exceeds a set level, the current from the SRS-ACC or IGN fuse flows to TERMINALS (C) 2, (A) 5, (C) 5 and (A) 2 of the center airbag sensor assembly to TERMINAL 1 of the side airbag squibs and the pretensioners to TERMINAL 2 to TERMINALS (C) 1, (A) 6, (C) 6 and (A) 1 of the center airbag sensor assembly to TERMINAL (B) 27, (B) 28 or BODY GROUND to GROUND, causing side airbag squibs and the pretensioners to operate.

The airbag stored inside the steering wheel pad is instantaneously expanded to soften the shock to the driver. The airbag stored inside the passenger's instrument panel is instantaneously expanded to soften the shock to the front passenger. Side airbags are instantaneously expanded to soften the shock of side to the driver and front passenger. The pretensioners make sure of the seat belt restrainability.

○ : PARTS LOCATION

Code	See Page	Code	See Page	Code	See Page	
A11	36 (1UZ-FE)	C8	B	40	P14	43
	38 (2JZ-GE)	C9	C	40	P15	43
A12	36 (1UZ-FE)	C12		40	S12	43
	38 (2JZ-GE)	D1		36 (1UZ-FE)	S13	43
A28	40			38 (2JZ-GE)	S23	44
A29	40	D4		40	S24	44
B6	40	J6		41		
C7	A	J9		41		

○ : JUNCTION BLOCK AND WIRE HARNESS CONNECTOR

Code	See Page	Junction Block and Wire Harness (Connector Location)
1D	26	Instrument Panel Wire and Driver Side J/B (Left Kick Panel)
1F	26	Cowl Wire and Driver Side J/B (Left Kick Panel)
1N	27	

□ : CONNECTOR JOINING WIRE HARNESS AND WIRE HARNESS

Code	See Page	Joining Wire Harness and Wire Harness (Connector Location)
EA1	46 (1UZ-FE)	Engine Wire and Cowl Wire (Inside of the ECU Box)
	48 (2JZ-GE)	
IF1	50	Cowl Wire and Cowl Wire (Right Side of the Steering Column)
II3	52	Engine Room Main Wire and Cowl Wire (Near the Passenger Side R/B)

▽ : GROUND POINTS

Code	See Page	Ground Points Location
EB	46 (1UZ-FE)	Left Fender
	48 (2JZ-GE)	
IF	50	Left Kick Panel
IG	50	Left Side of the Cowl Panel

A11
YELLOW



A12
YELLOW

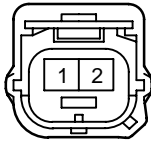

A28
YELLOW

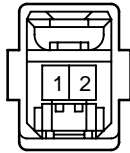

A29
YELLOW

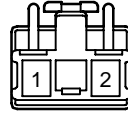

B6

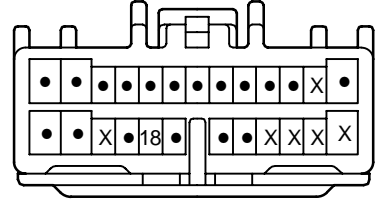

C7 (A)
YELLOW

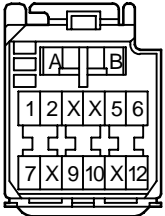

C8 (B)
YELLOW

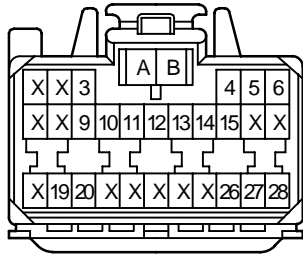

C9 (C)
YELLOW

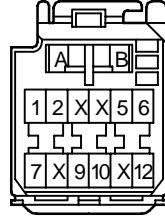

C12

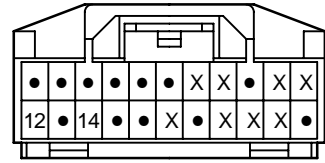

D1
(1UZ-FE) BLACK

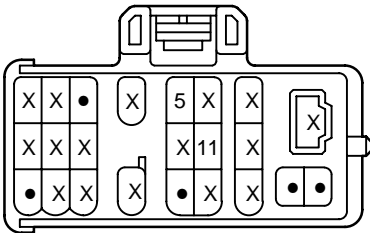

D1
(2JZ-FE) BLACK

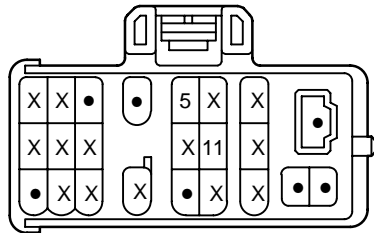

D4

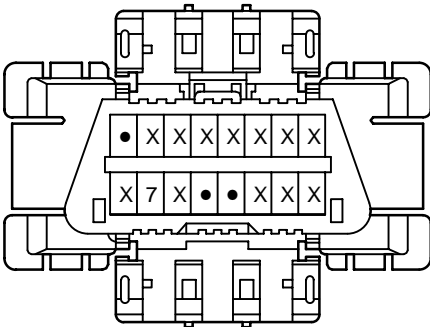

J6

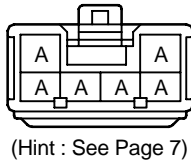

J9
(1UZ-FE)

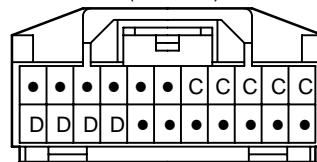

J9
(2JZ-GE)

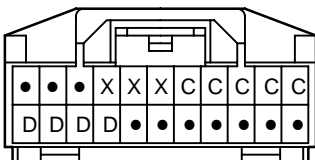

P14
YELLOW

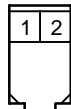

P15
YELLOW



S12
YELLOW

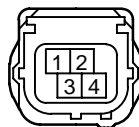

S13
YELLOW

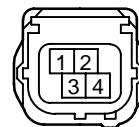

(Hint : See Page 7)

SRS

S23
YELLOW



S24
YELLOW



STARTING AND IGNITION (1UZ-FE)

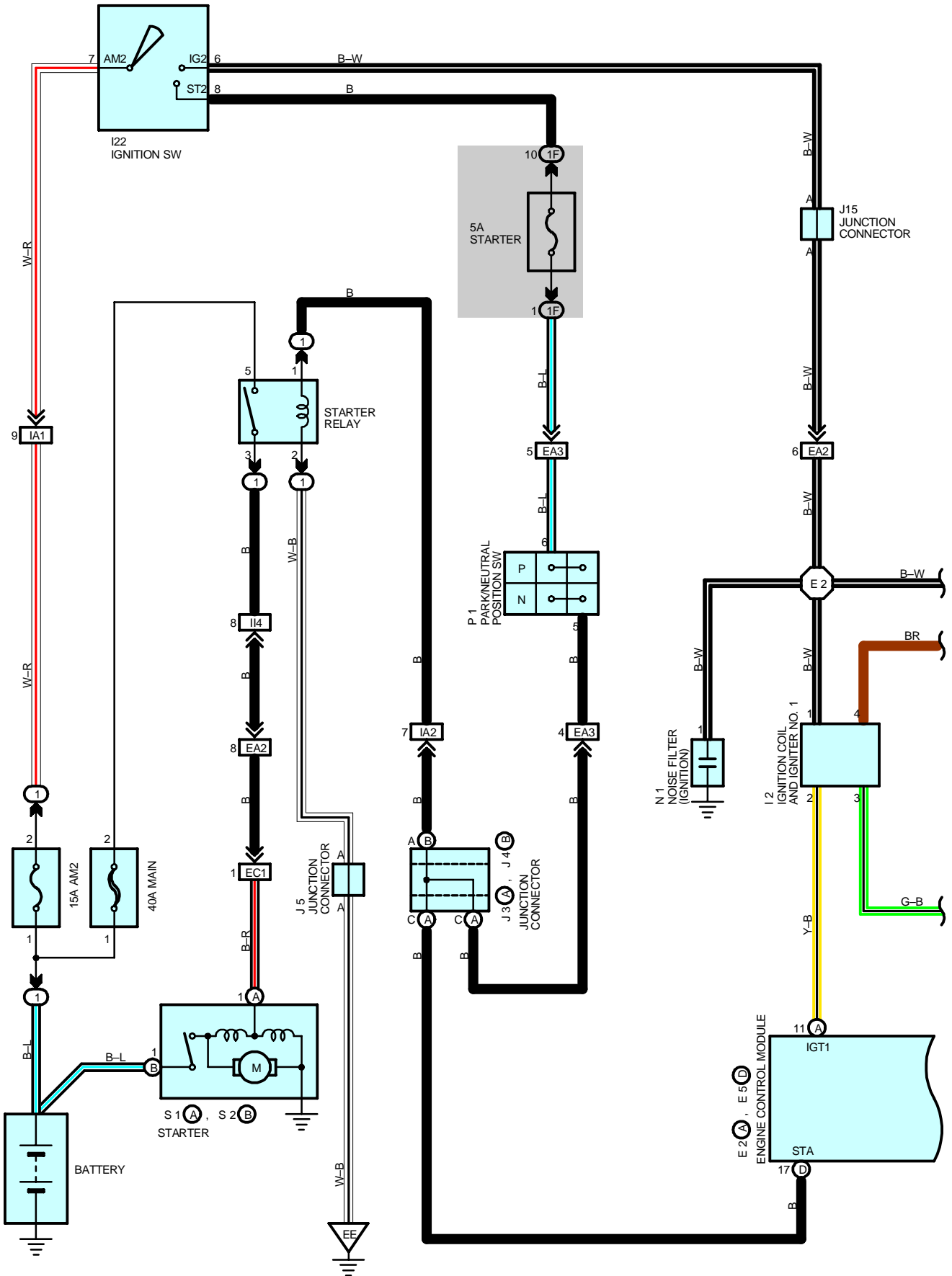

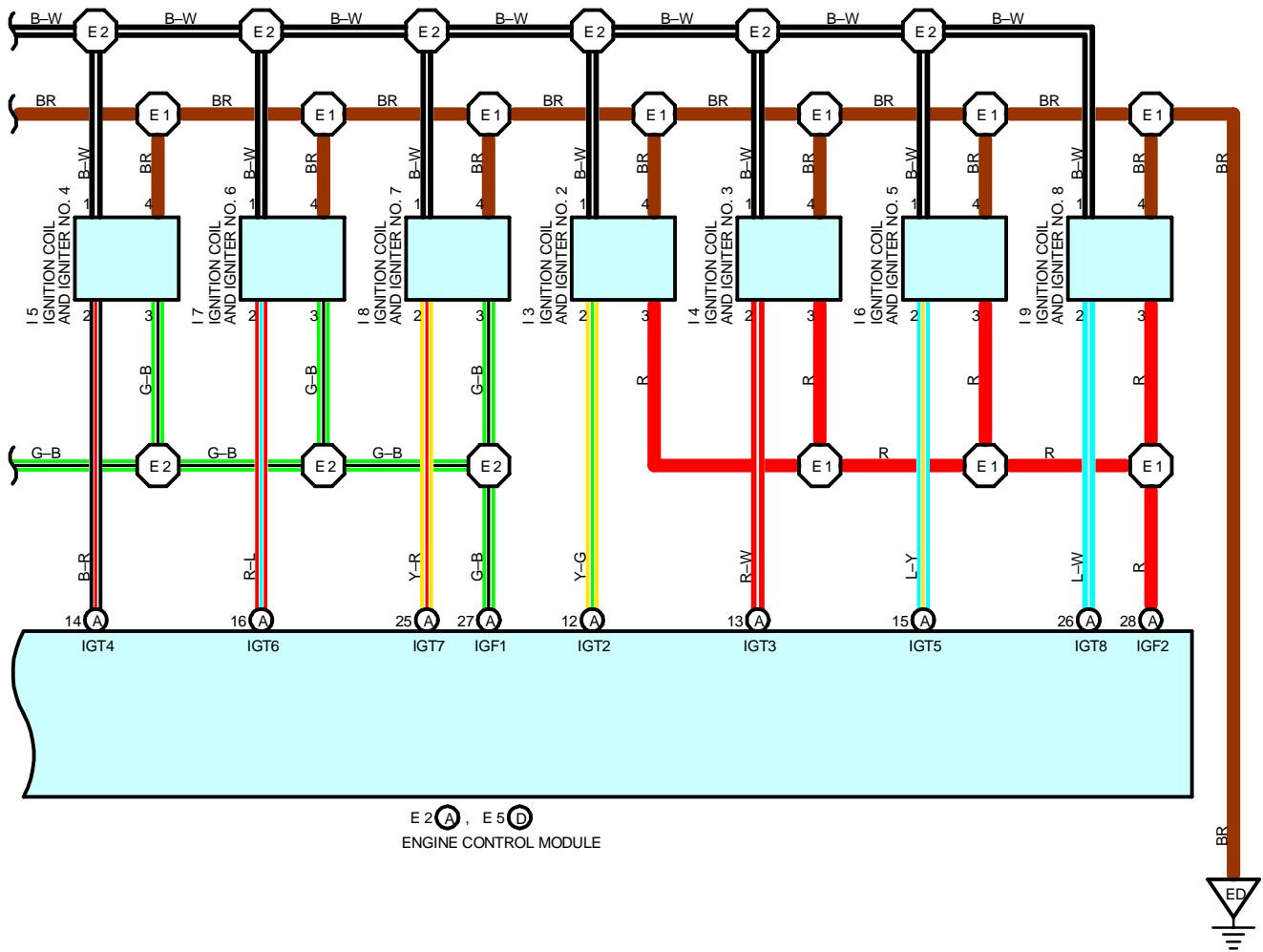

STARTING AND IGNITION (1UZ-FE)

SERVICE HINTS

I22 IGNITION SW

7-6 : Closed with ignition SW at **ON** or **ST** position

7-8 : Closed with ignition SW at **ST** position

P1 PARK/NEUTRAL POSITION SW

6-5 : Closed with A/T shift lever in **P** or **N** position

S1 (A), S2 (B) STARTER

Points closed with Park/Neutral position SW at **P** or **N** position and ignition SW at **ST** position

○ : PARTS LOCATION

Code	See Page	Code	See Page	Code	See Page		
E2	A	36 (1UZ-FE)	I7	37 (1UZ-FE)	J15	41	
E5	D	36 (1UZ-FE)	I8	37 (1UZ-FE)	N1	37 (1UZ-FE)	
I2		37 (1UZ-FE)	I9	37 (1UZ-FE)	P1	37 (1UZ-FE)	
I3		37 (1UZ-FE)	I22	41	S1	A	37 (1UZ-FE)
I4		37 (1UZ-FE)	J3	A	S2	B	37 (1UZ-FE)
I5		37 (1UZ-FE)	J4	B			
I6		37 (1UZ-FE)	J5	37 (1UZ-FE)			

○ : RELAY BLOCKS

Code	See Page	Relay Blocks (Relay Block Location)
1	22	Engine Room No.1 R/B (Engine Compartment Right)

○ : JUNCTION BLOCK AND WIRE HARNESS CONNECTOR

Code	See Page	Junction Block and Wire Harness (Connector Location)
1F	26	Cowl Wire and Driver Side J/B (Left Kick Panel)

□ : CONNECTOR JOINING WIRE HARNESS AND WIRE HARNESS

Code	See Page	Joining Wire Harness and Wire Harness (Connector Location)
EA2	46 (1UZ-FE)	Engine Wire and Cowl Wire (Inside of the ECU Box)
EA3		
EC1	46 (1UZ-FE)	Engine No.2 Wire and Engine Wire (Near the Starter)
IA1	50	Engine Room Main Wire and Cowl Wire (Near the Driver Side J/B)
IA2		
II4	52	Engine Room Main Wire and Cowl Wire (Near the Passenger Side R/B)

▽ : GROUND POINTS

Code	See Page	Ground Points Location
ED	46 (1UZ-FE)	LH Bank of the Cylinder Head
EE	46 (1UZ-FE)	Under the ABS & TRAC & VSC Actuator

○ : SPLICE POINTS

Code	See Page	Wire Harness with Splice Points	Code	See Page	Wire Harness with Splice Points
E1	46 (1UZ-FE)	Engine Wire	E2	46 (1UZ-FE)	Engine Wire

E2 (A)

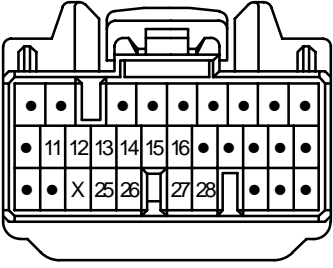

E5 (D)

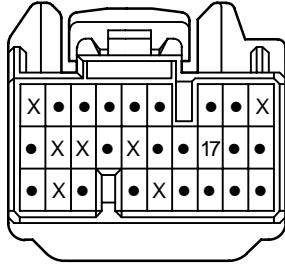

I2
BLACK

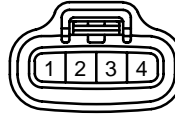

I3
BLACK



I4
BLACK



I5
BLACK



I6
BLACK



I7
BLACK



I8
BLACK



I9
BLACK



I22

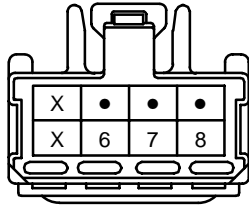

J3 (A)

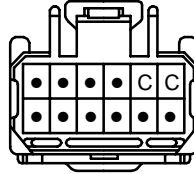

(Hint : See Page 7)

J4 (B)

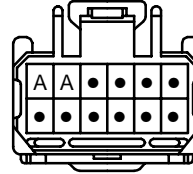

(Hint : See Page 7)

J5
BLUE



(Hint : See Page 7)

J15

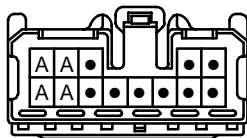

(Hint : See Page 7)

N1
GRAY



P1
GRAY

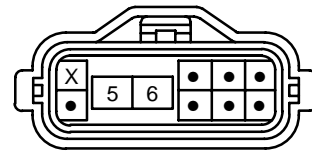

S1 (A)
BLACK



S2 (B)

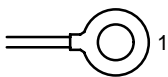

STARTING AND IGNITION (2JZ-GE)

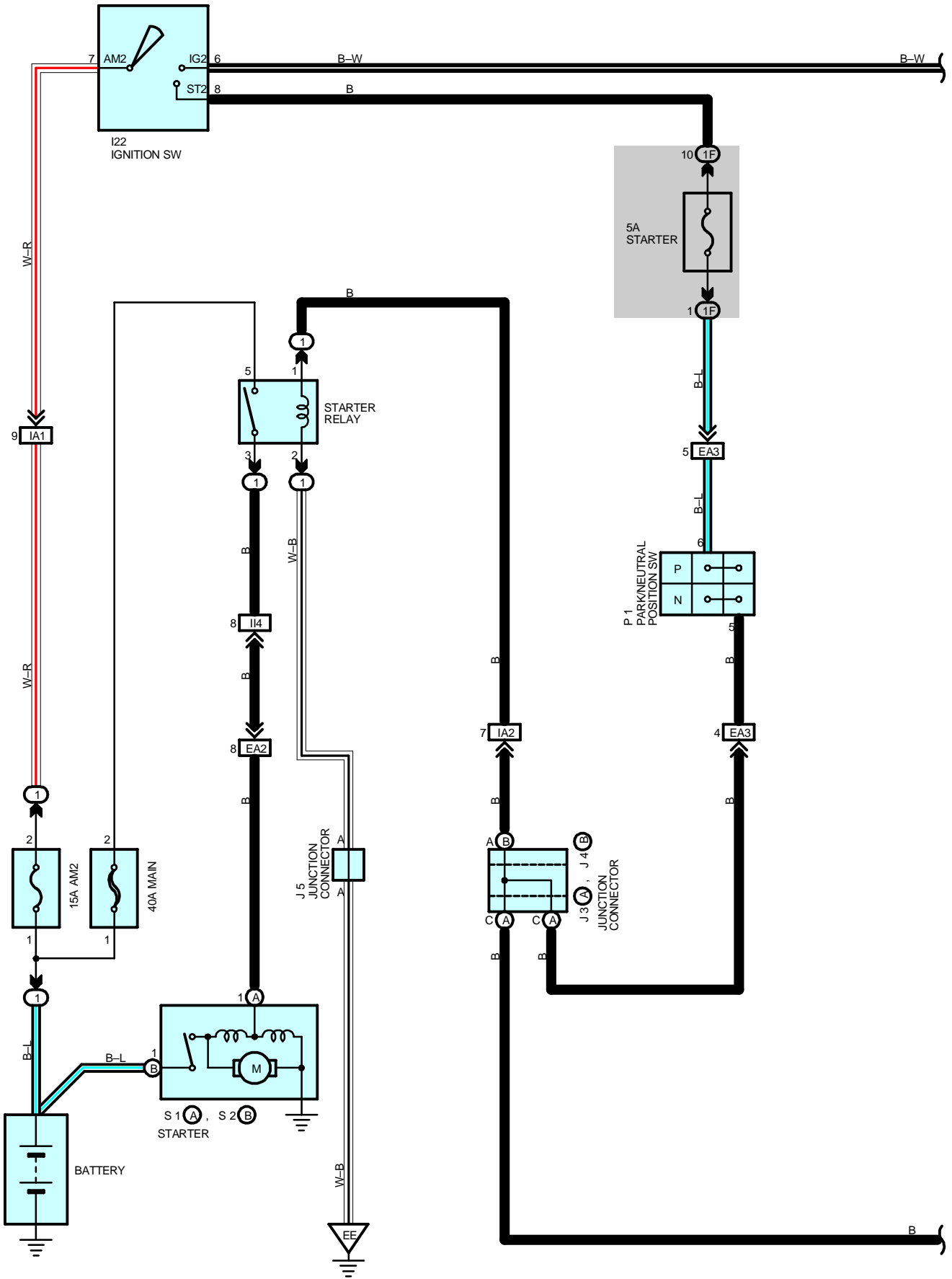

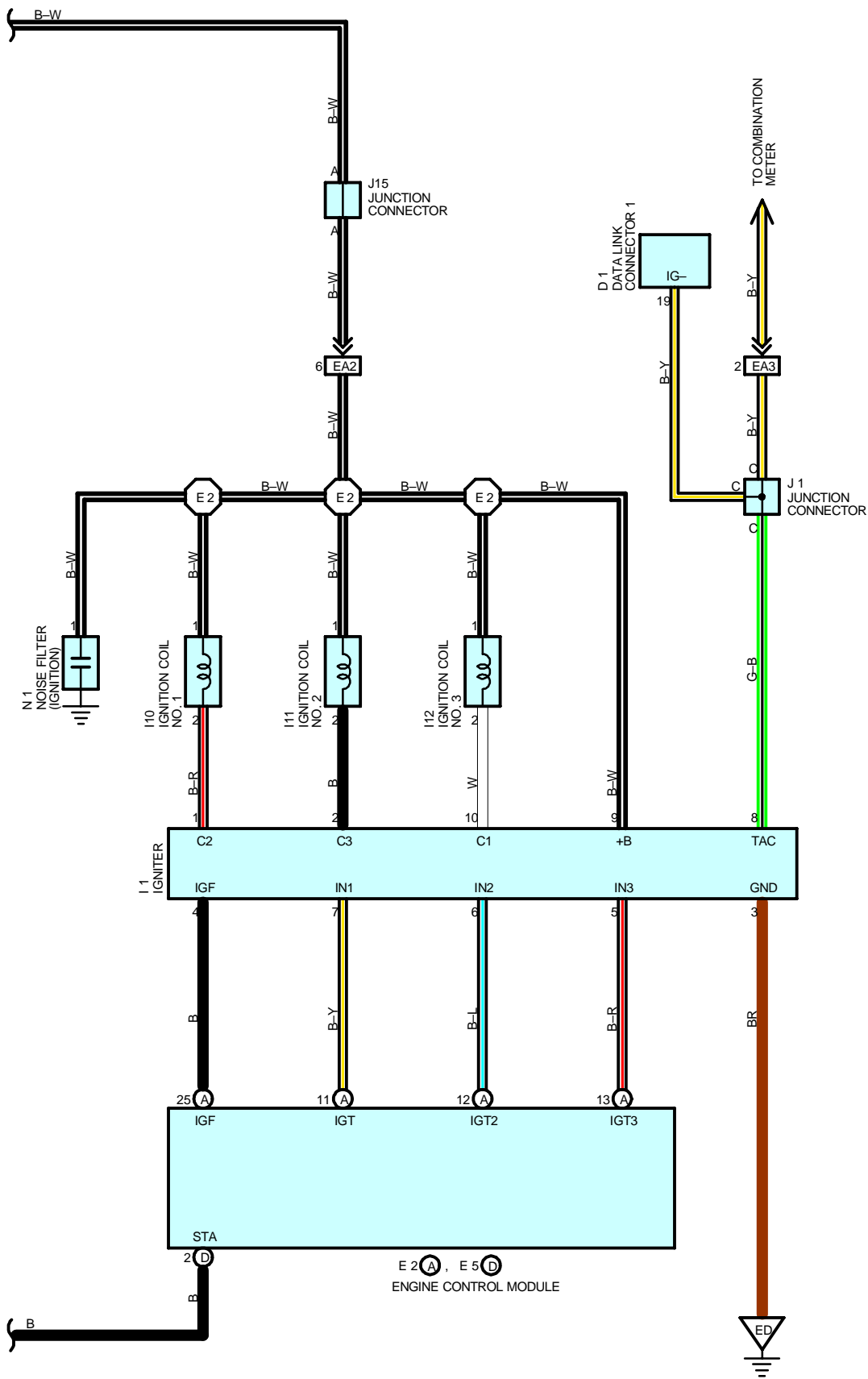

STARTING AND IGNITION (2JZ-GE)

SERVICE HINTS

I22 IGNITION SW

- 7-6 : Closed with ignition SW at **ON** or **ST** position
- 7-8 : Closed with ignition SW at **ST** position

P1 PARK/NEUTRAL POSITION SW

- 6-5 : Closed with A/T shift lever in **P** or **N** position

S1 (A), S2 (B) STARTER

- Points closed with Park/Neutral position SW at **P** or **N** position and ignition SW at **ST** position

○ : PARTS LOCATION

Code	See Page	Code	See Page	Code	See Page	
D1		I12	39 (2JZ-GE)	J15	41	
E2	A	I22	41	N1	39 (2JZ-GE)	
E5	D	J1	39 (2JZ-GE)	P1	39 (2JZ-GE)	
I1	39 (2JZ-GE)	J3	A	S1	A	39 (2JZ-GE)
I10	39 (2JZ-GE)	J4	B	S2	B	39 (2JZ-GE)
I11	39 (2JZ-GE)	J5	39 (2JZ-GE)			

○ : RELAY BLOCKS

Code	See Page	Relay Blocks (Relay Block Location)
1	22	Engine Room No.1 R/B (Engine Compartment Right)

○ : JUNCTION BLOCK AND WIRE HARNESS CONNECTOR

Code	See Page	Junction Block and Wire Harness (Connector Location)
1F	26	Cowl Wire and Driver Side J/B (Left Kick Panel)

□ : CONNECTOR JOINING WIRE HARNESS AND WIRE HARNESS

Code	See Page	Joining Wire Harness and Wire Harness (Connector Location)
EA2	48 (2JZ-GE)	Engine Wire and Cowl Wire (Inside of the ECU Box)
EA3		
IA1	50	Engine Room Main Wire and Cowl Wire (Near the Driver Side J/B)
IA2		
II4	52	Engine Room Main Wire and Cowl Wire (Near the Passenger Side R/B)

▽ : GROUND POINTS

Code	See Page	Ground Points Location
ED	48 (2JZ-GE)	Rear Side of the Intake Manifold
EE	48 (2JZ-GE)	Under the ABS & TRAC & VSC Actuator

○ : SPLICE POINTS

Code	See Page	Wire Harness with Splice Points	Code	See Page	Wire Harness with Splice Points
E 2	48 (2JZ-GE)	Engine Wire			

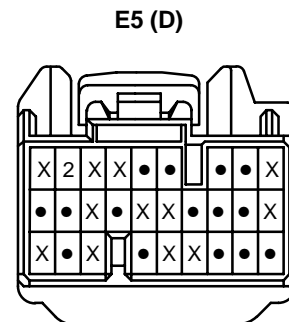
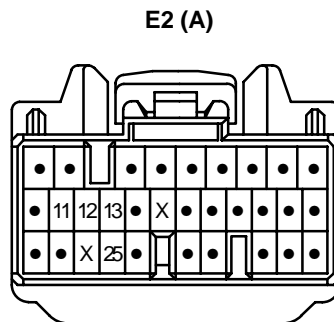
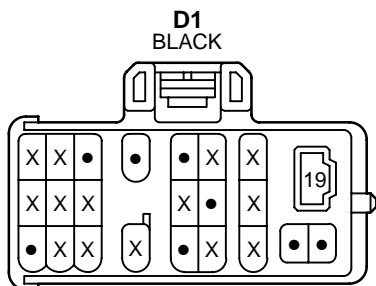

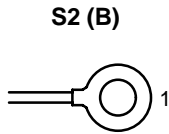
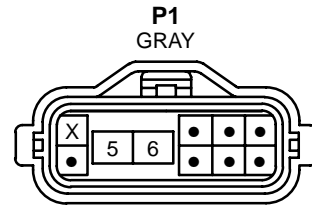
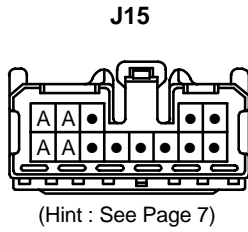
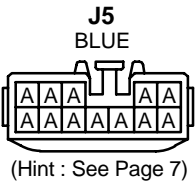
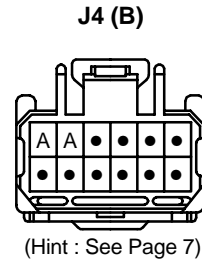
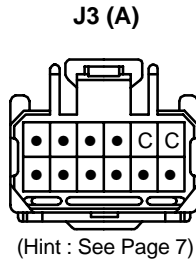
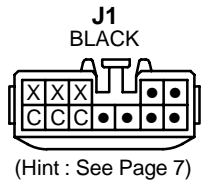
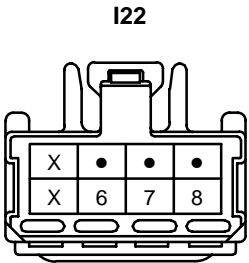
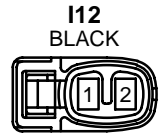
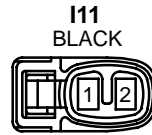
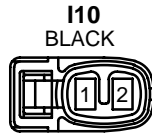
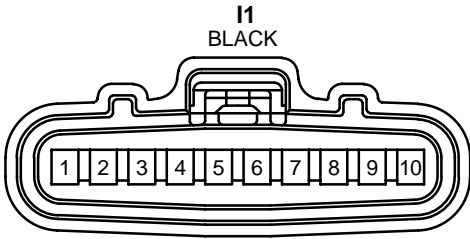

STOP LIGHT

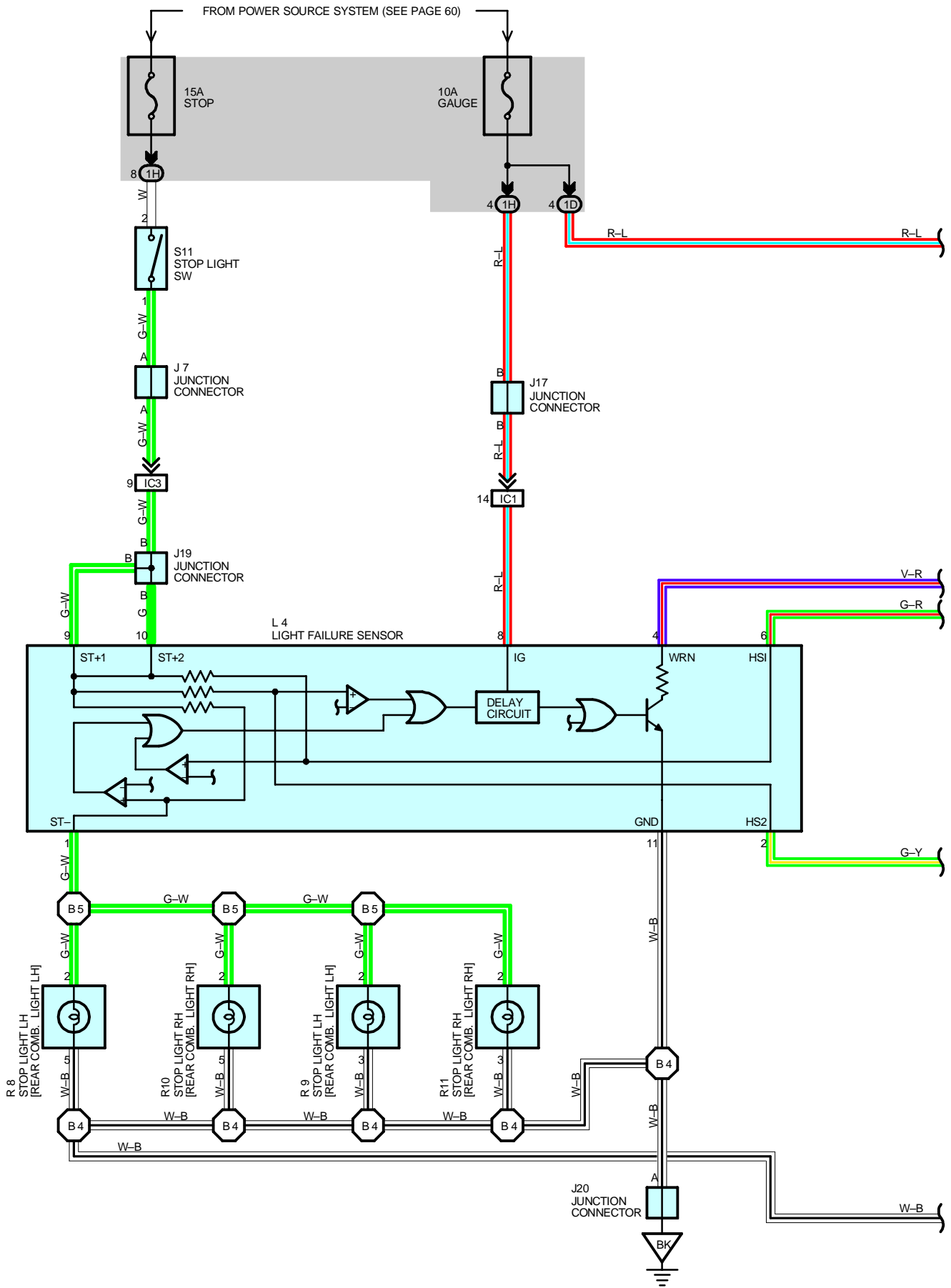

* 1 : W/ REAR SPOILER
 * 2 : W/O REAR SPOILER

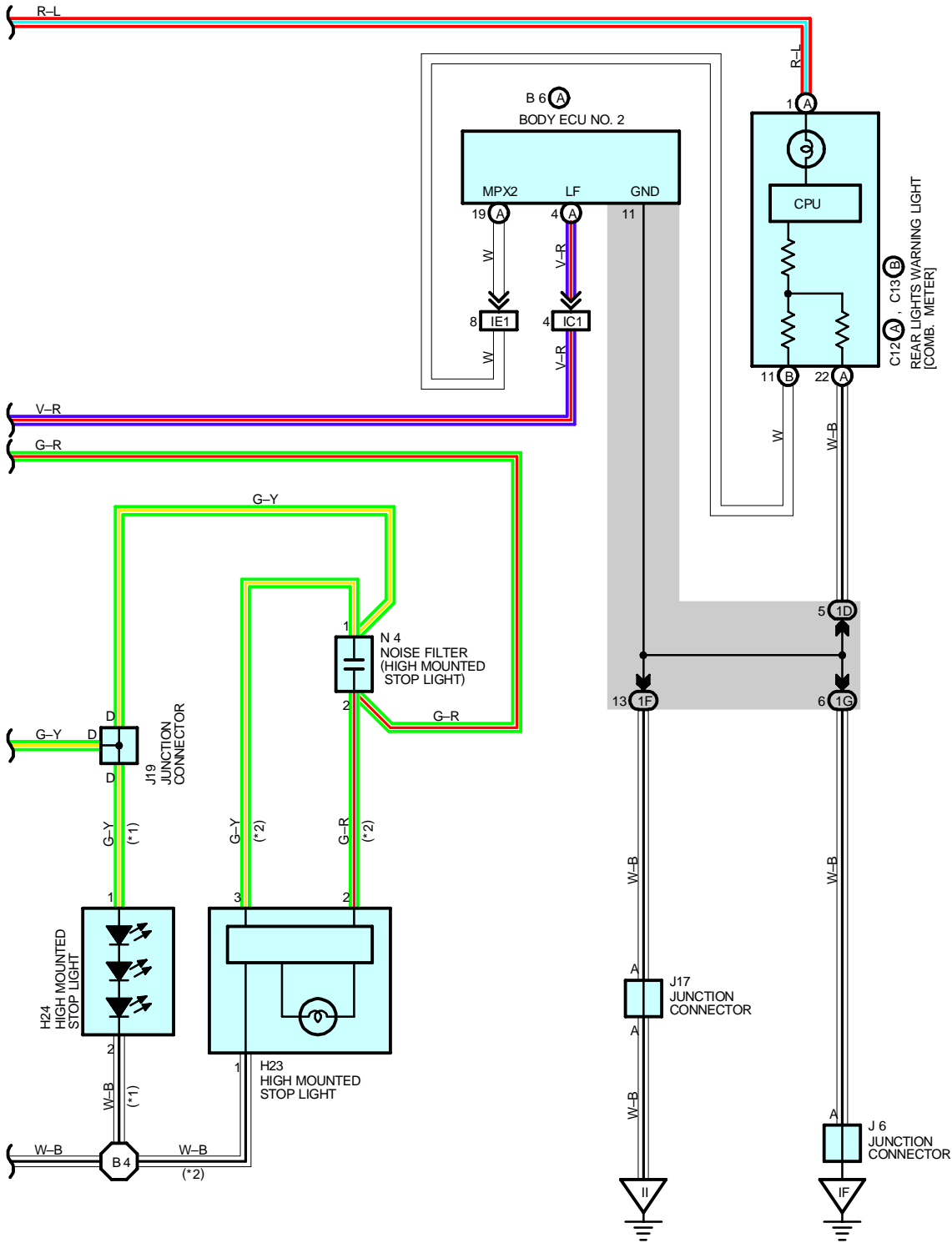

STOP LIGHT

SYSTEM OUTLINE

The current always flows from the STOP fuse into TERMINAL 2 of the stop light SW. If the brake pedal is depressed, the stop lights light up.

STOP LIGHT DISCONNECTION WARNING

If any stop light wiring is faulty when the brake pedal is depressed with the ignition SW set at ON, the light failure sensor detects a voltage difference and inputs the signal to TERMINAL 4 of the body ECU No.2. The body ECU No.2 controls the combination meter through the communication to turn on the rear lights warning light to warn the driver. The warning light is remained lit until the ignition SW is turned to the OFF position.

SERVICE HINTS

S11 STOP LIGHT SW

1-2 : Closed with brake pedal depressed

L4 LIGHT FAILURE SENSOR

9, 10-GROUND : Approx. 12 volts with stop light SW on

8-GROUND : Approx. 12 volts with Ignition SW at **ON** or **ST** position

11-GROUND : Always continuity

○ : PARTS LOCATION

Code	See Page	Code	See Page	Code	See Page	
B6	A	40	J7	41	R8	43
C12	A	40	J17	41	R9	43
C13	B	40	J19	42	R10	43
H23		42	J20	42	R11	43
H24		42	L4	43	S11	41
J6		41	N4	43		

○ : JUNCTION BLOCK AND WIRE HARNESS CONNECTOR

Code	See Page	Junction Block and Wire Harness (Connector Location)	
1D	26	Instrument Panel Wire and Driver Side J/B (Left Kick Panel)	
1F	26		
1G	27		Cowl Wire and Driver Side J/B (Left Kick Panel)
1H			

□ : CONNECTOR JOINING WIRE HARNESS AND WIRE HARNESS

Code	See Page	Joining Wire Harness and Wire Harness (Connector Location)
IC1	50	Floor No.2 Wire and Cowl Wire (Left Kick Panel)
IC3		
IE1	50	Instrument Panel Wire and Cowl Wire (Left Side of the Steering Column)

▽ : GROUND POINTS

Code	See Page	Ground Points Location
IF	50	Left Kick Panel
II	50	Right Side of the Cowl Panel
BK	54	Quarter Panel LH

○ : SPLICE POINTS

Code	See Page	Wire Harness with Splice Points	Code	See Page	Wire Harness with Splice Points
B4	54	Floor No.2 Wire	B5	54	Floor No.2 Wire

B6 (A)

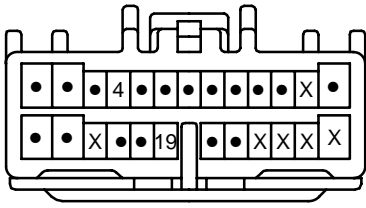

C12 (A)

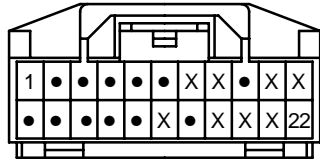

C13 (B)

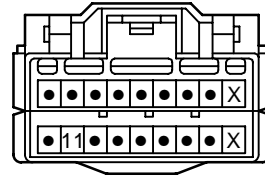

H23

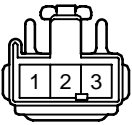

H24

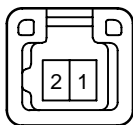

J6

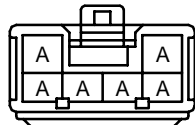

(Hint : See Page 7)

**J7
GRAY**

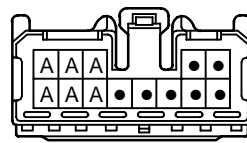

(Hint : See Page 7)

J17



(Hint : See Page 7)

**J19
BLUE**

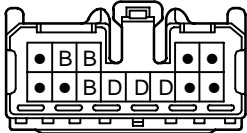

(Hint : See Page 7)

J20

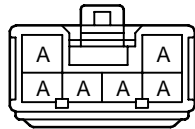

(Hint : See Page 7)

L4

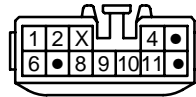

N4

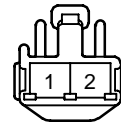

R8

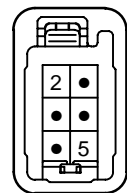

R9

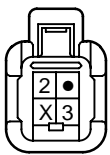

R10

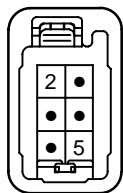

R11



**S11
BLUE**

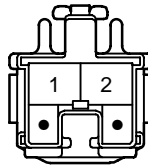

TAILLIGHT

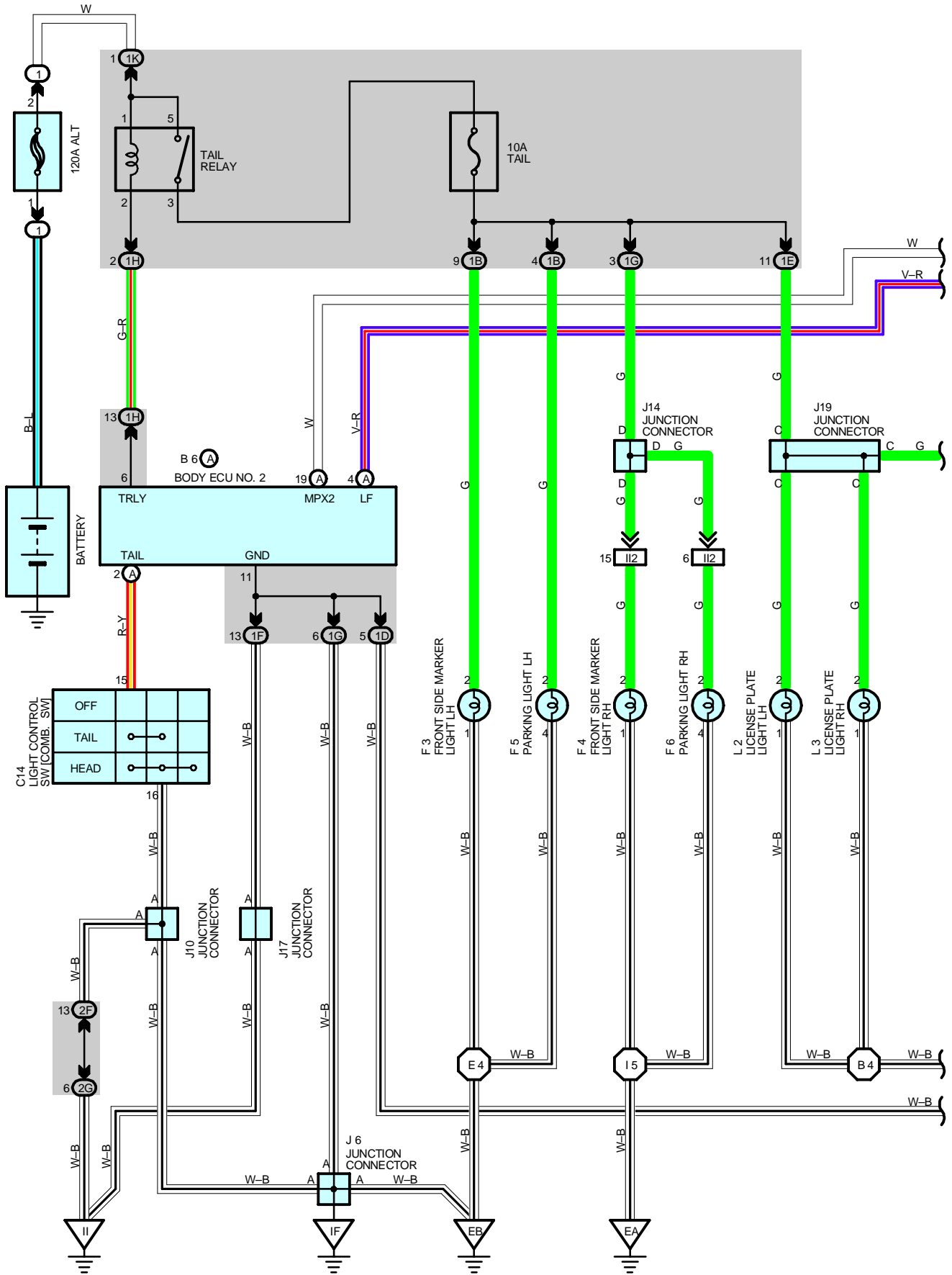

FROM POWER SOURCE SYSTEM (SEE PAGE 60)

* 1 : CANADA, TAIWAN

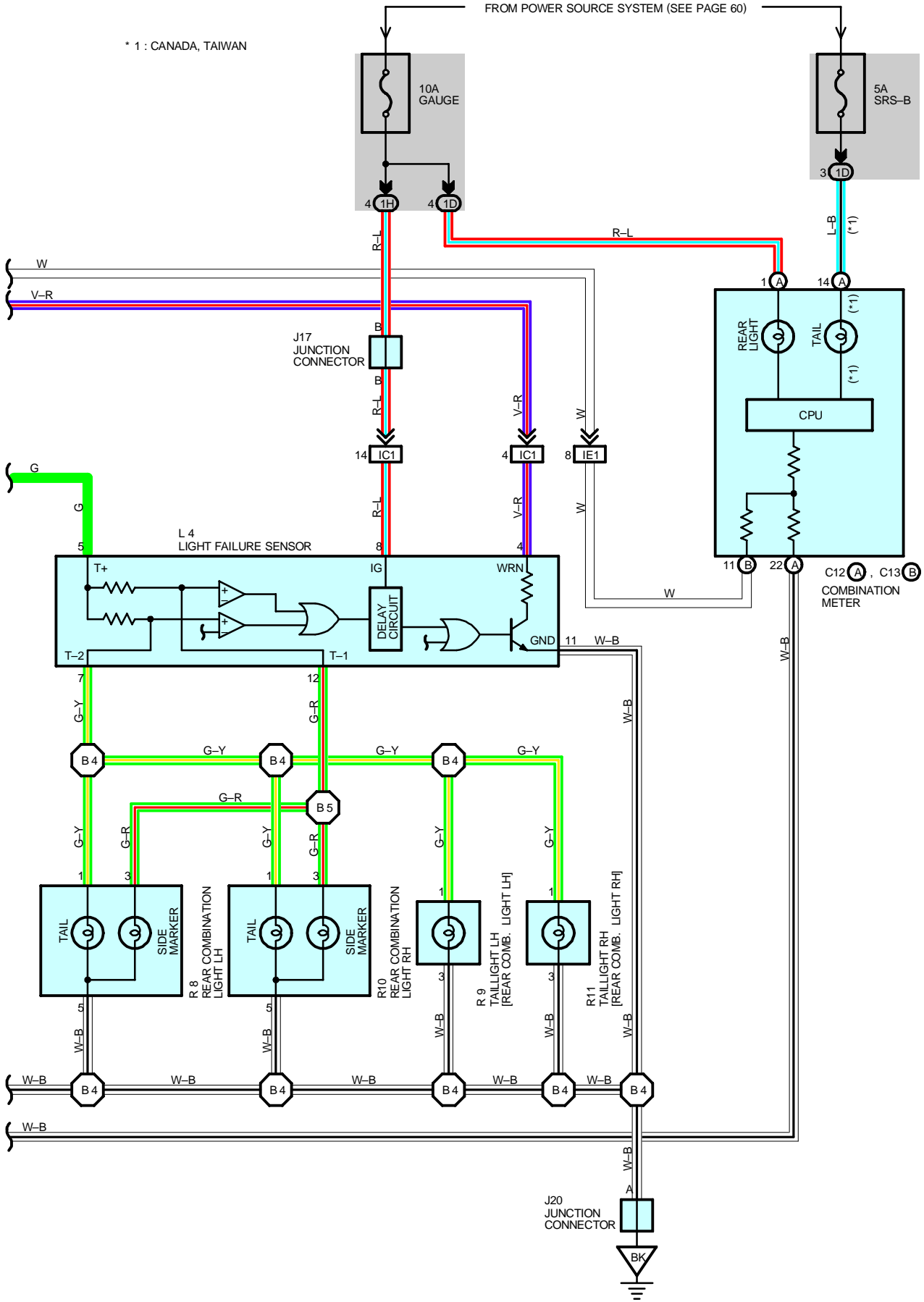

TAILLIGHT

SYSTEM OUTLINE

When the light control SW is turned to the TAIL or HEAD position, the signal is input to TERMINAL TAIL of the body ECU No.2. This activates the body ECU No.2 to flow the current from the battery into the ALT fuse, TAIL relay (Coil side), TERMINAL TRLY of the body ECU No.2 to GROUND in that order to turn on the TAIL relay. The current flows from the TAIL fuse into the parking lights, front side marker lights, license plate lights, TERMINAL 5 of the light failure sensor to TERMINAL 7 and 12 to taillights, and rear side marker lights in that order to turn on each light.

TAILLIGHT DISCONNECTION WARNING

If any taillight wiring is faulty when the ignition SW is turned to the ON position with the light control SW set at TAIL or HEAD, the light failure sensor detects a voltage difference and inputs the signal to TERMINAL LF of the body ECU No.2. The body ECU No.2 is activated to turn on the rear lights warning light in the combination meter to warn the driver.

SERVICE HINTS

C14 LIGHT CONTROL SW [COMB. SW]

15-16 : Closed with light control SW at **TAIL** or **HEAD** position

L4 LIGHT FAILURE SENSOR

8-GROUND : Approx. 12 volts with ignition SW at **ON** or **ST** position

5-GROUND : Approx. 12 volts with light control SW at **TAIL** or **HEAD** position

11-GROUND : Always continuity

○ : PARTS LOCATION

Code	See Page	Code	See Page	Code	See Page
B6	A 40	F5	38 (2JZ-GE)	L2	43
C12	A 40	F6	36 (1UZ-FE)	L3	43
C13	B 40		38 (2JZ-GE)	L4	43
C14	40	J6	41	R8	43
F3	36 (1UZ-FE)	J10	41	R9	43
	38 (2JZ-GE)	J14	41	R10	43
F4	36 (1UZ-FE)	J17	41	R11	43
	38 (2JZ-GE)	J19	42		
F5	36 (1UZ-FE)	J20	42		

○ : RELAY BLOCKS

Code	See Page	Relay Blocks (Relay Block Location)
1	22	Engine Room No.1 R/B (Engine Compartment Right)

○ : JUNCTION BLOCK AND WIRE HARNESS CONNECTOR

Code	See Page	Junction Block and Wire Harness (Connector Location)
1B	26	Cowl Wire and Driver Side J/B (Left Kick Panel)
1D	26	Instrument Panel Wire and Driver Side J/B (Left Kick Panel)
1E	26	Floor No.2 Wire and Driver Side J/B (Left Kick Panel)
1F	26	Cowl Wire and Driver Side J/B (Left Kick Panel)
1G	27	
1H		
1K	26	Engine Room Main Wire and Driver Side J/B (Left Kick Panel)
2F	28	Cowl Wire and Passenger Side J/B (Right Kick Panel)
2G	29	

□ : CONNECTOR JOINING WIRE HARNESS AND WIRE HARNESS

Code	See Page	Joining Wire Harness and Wire Harness (Connector Location)
IC1	50	Floor No.2 Wire and Cowl Wire (Left Kick Panel)
IE1	50	Instrument Panel Wire and Cowl Wire (Left Side of the Steering Column)



: GROUND POINTS

Code	See Page	Ground Points Location
EA	46 (1UZ-FE)	Right Fender
	48 (2JZ-GE)	
EB	46 (1UZ-FE)	Left Fender
	48 (2JZ-GE)	
IF	50	Left Kick Panel
II	50	Right Side of the Cowl Panel
BK	54	Quarter Panel LH



: SPLICE POINTS

Code	See Page	Wire Harness with Splice Points	Code	See Page	Wire Harness with Splice Points
E4	46 (1UZ-FE)	Cowl Wire	B4	54	Floor No.2 Wire
	48 (2JZ-GE)		B5		
I5	52	Engine Room Main Wire			

B6 (A)

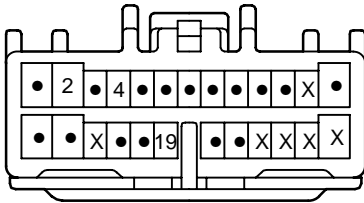

C12 (A)

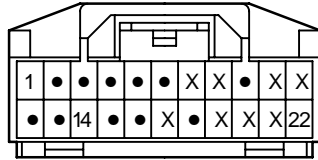

C13 (B)

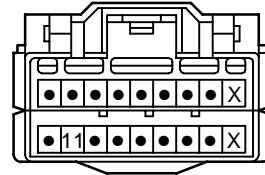

C14

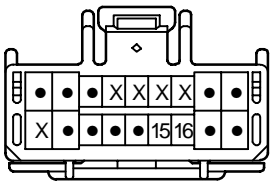

**F3
GRAY**



**F4
GRAY**



**F5
GRAY**



**F6
GRAY**



J6

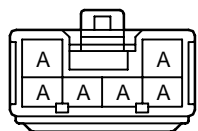

(Hint : See Page 7)

**J10
ORANGE**

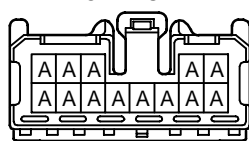

(Hint : See Page 7)

J14

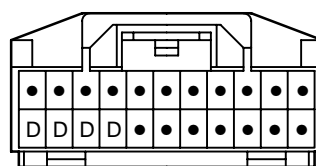

(Hint : See Page 7)

J17



(Hint : See Page 7)

**J19
BLUE**

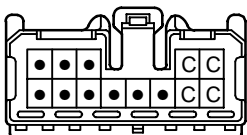

(Hint : See Page 7)

J20

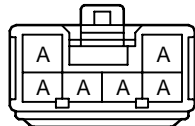

(Hint : See Page 7)

L2

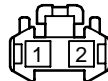

L3

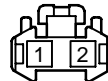

L4

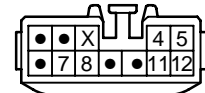

TAILLIGHT

R8

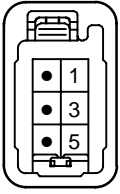

R9

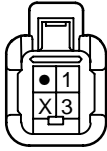

R10

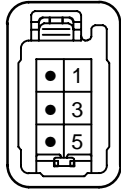

R11



FROM POWER SOURCE SYSTEM (SEE PAGE 60)

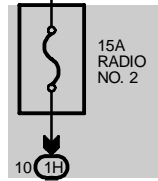
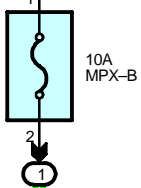

- * 1 : W/ LEXUS NAVIGATION SYSTEM
- * 2 : W/O LEXUS NAVIGATION SYSTEM
- * 3 : 1UZ-FE
- * 4 : 2JZ-GE

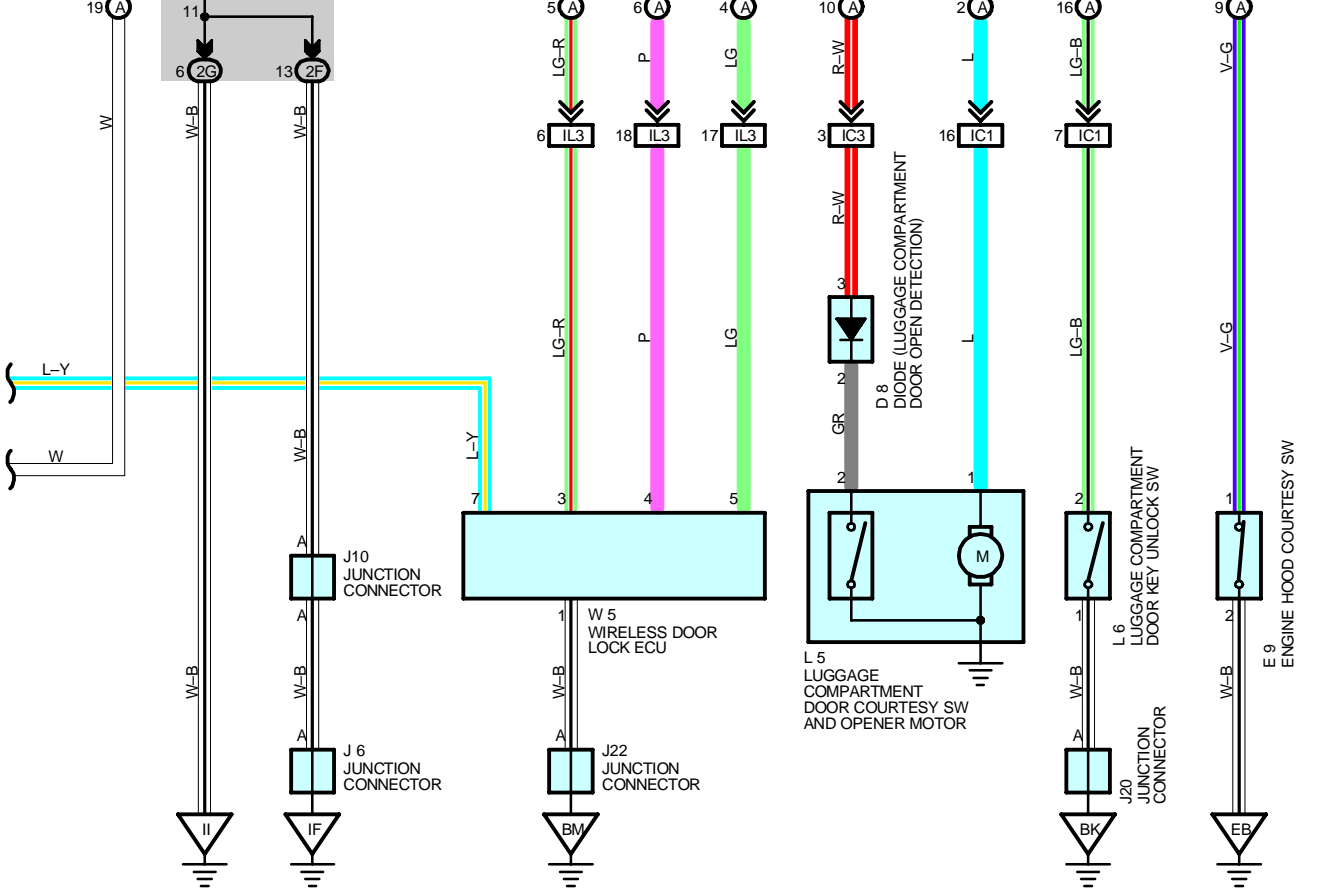
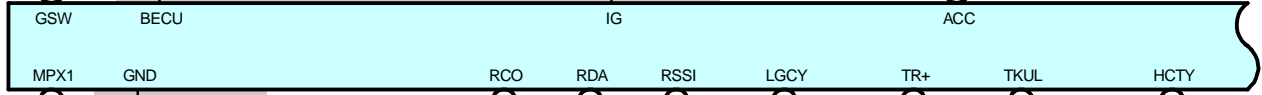
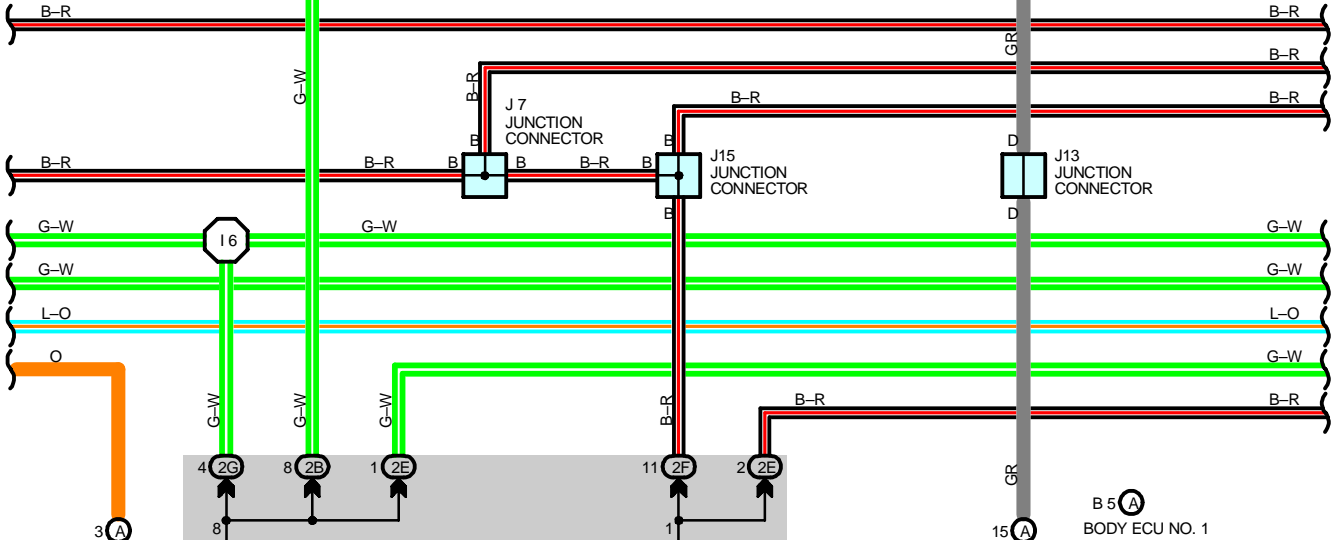

THEFT DETERRENT AND DOOR LOCK CONTROL

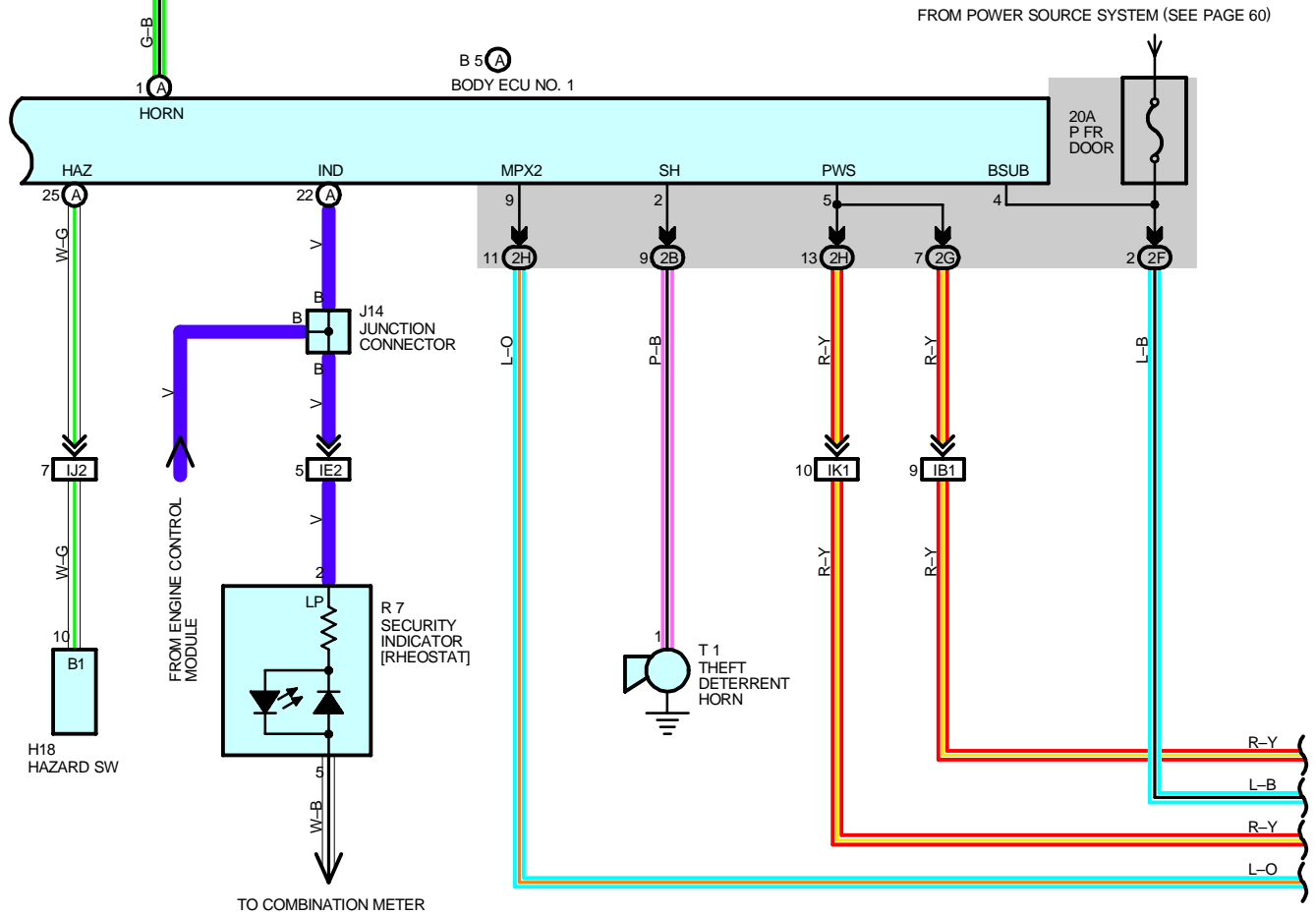
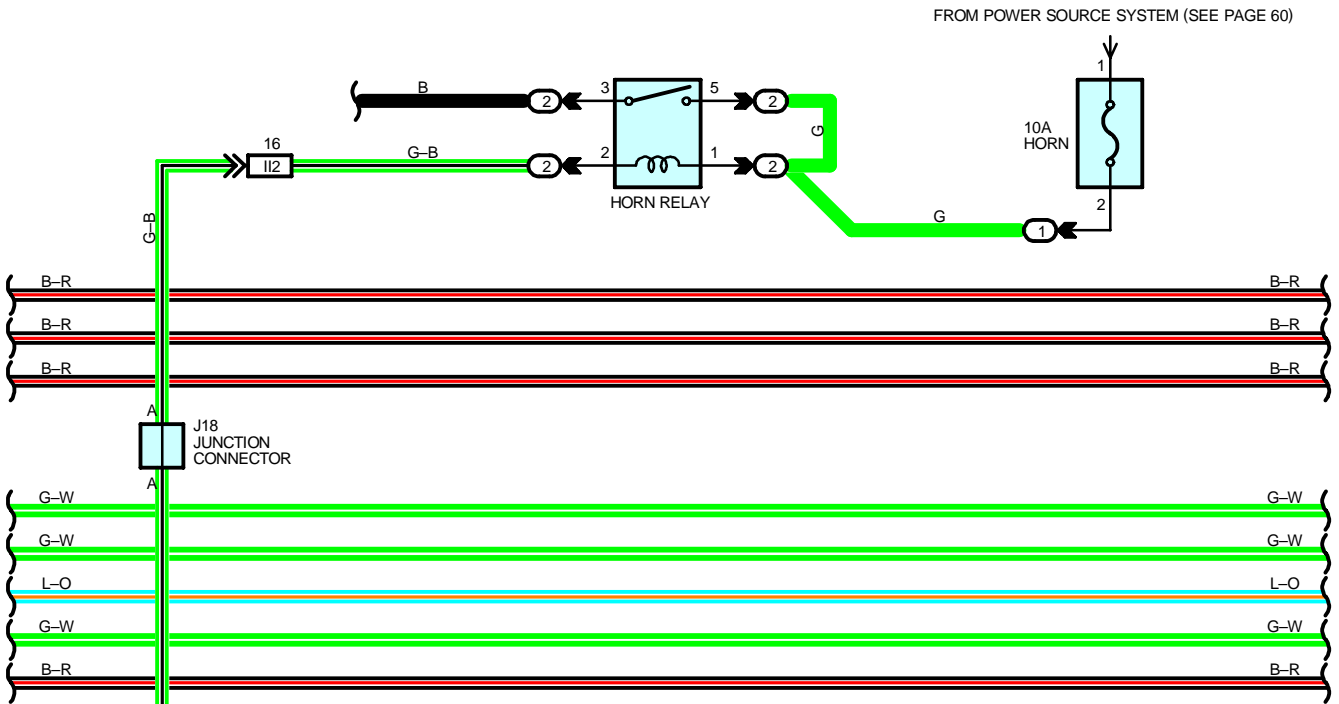

FROM POWER SOURCE SYSTEM (SEE PAGE 60)

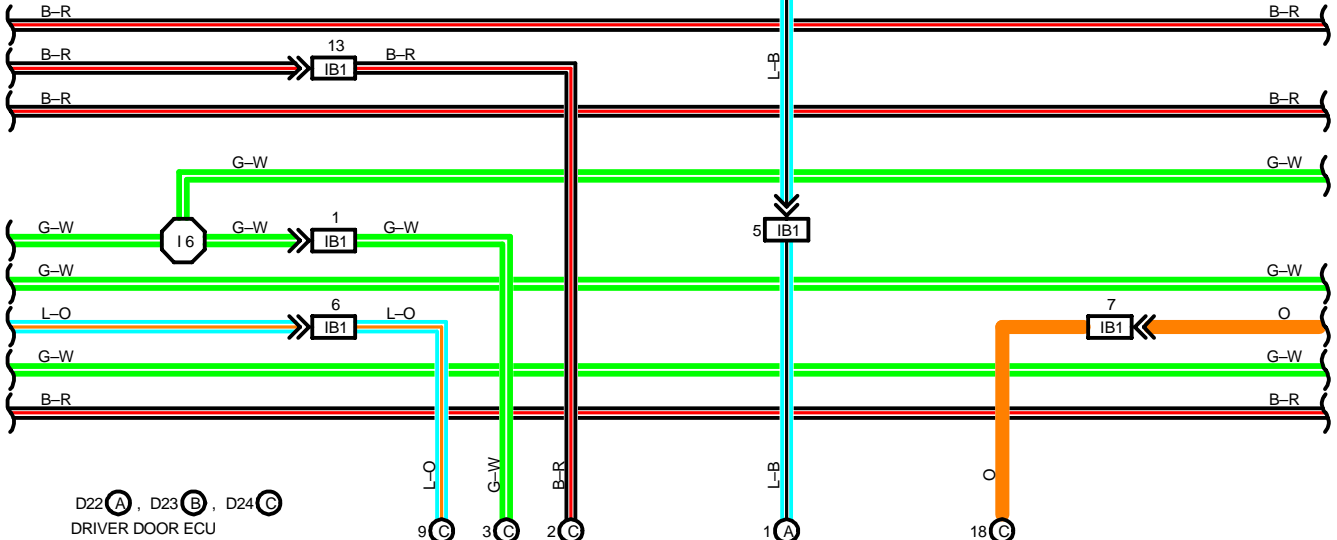
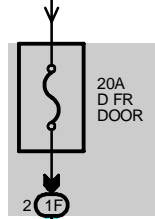

D22 (A), D23 (B), D24 (C)
DRIVER DOOR ECU

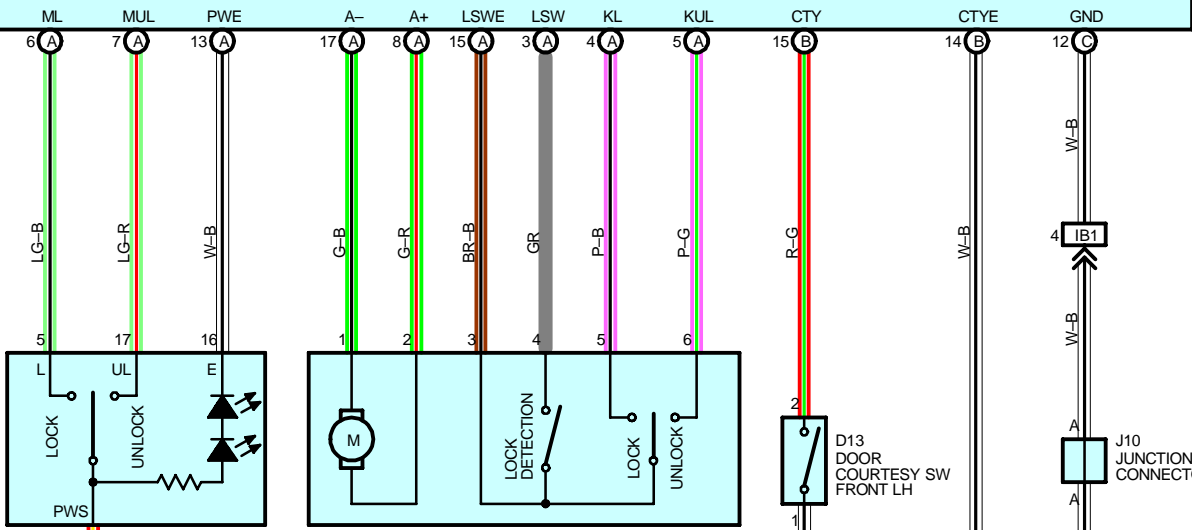

P11
DOOR LOCK CONTROL
SW LH [POWER WINDOW
MASTER SW]

D18
DOOR LOCK MOTOR, DOOR KEY LOCK
AND UNLOCK SW AND DOOR LOCK
DETECTION SW FRONT LH

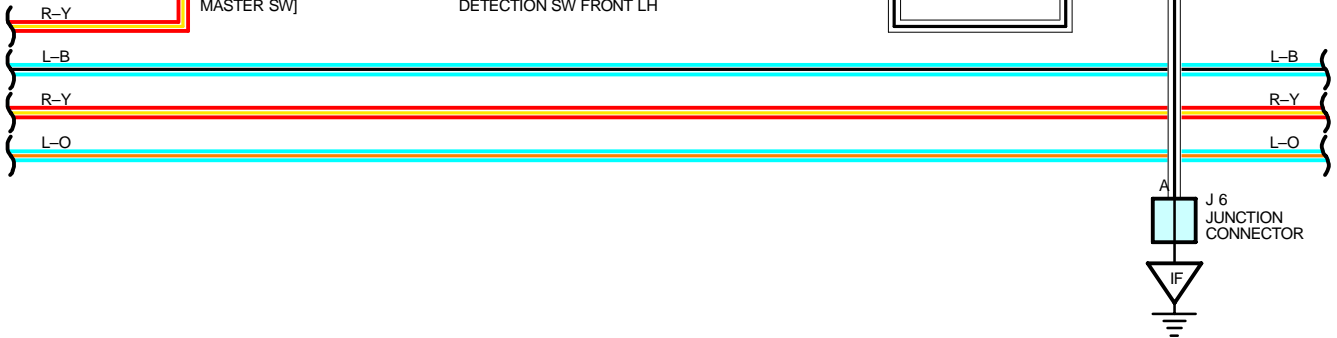

THEFT DETERRENT AND DOOR LOCK CONTROL

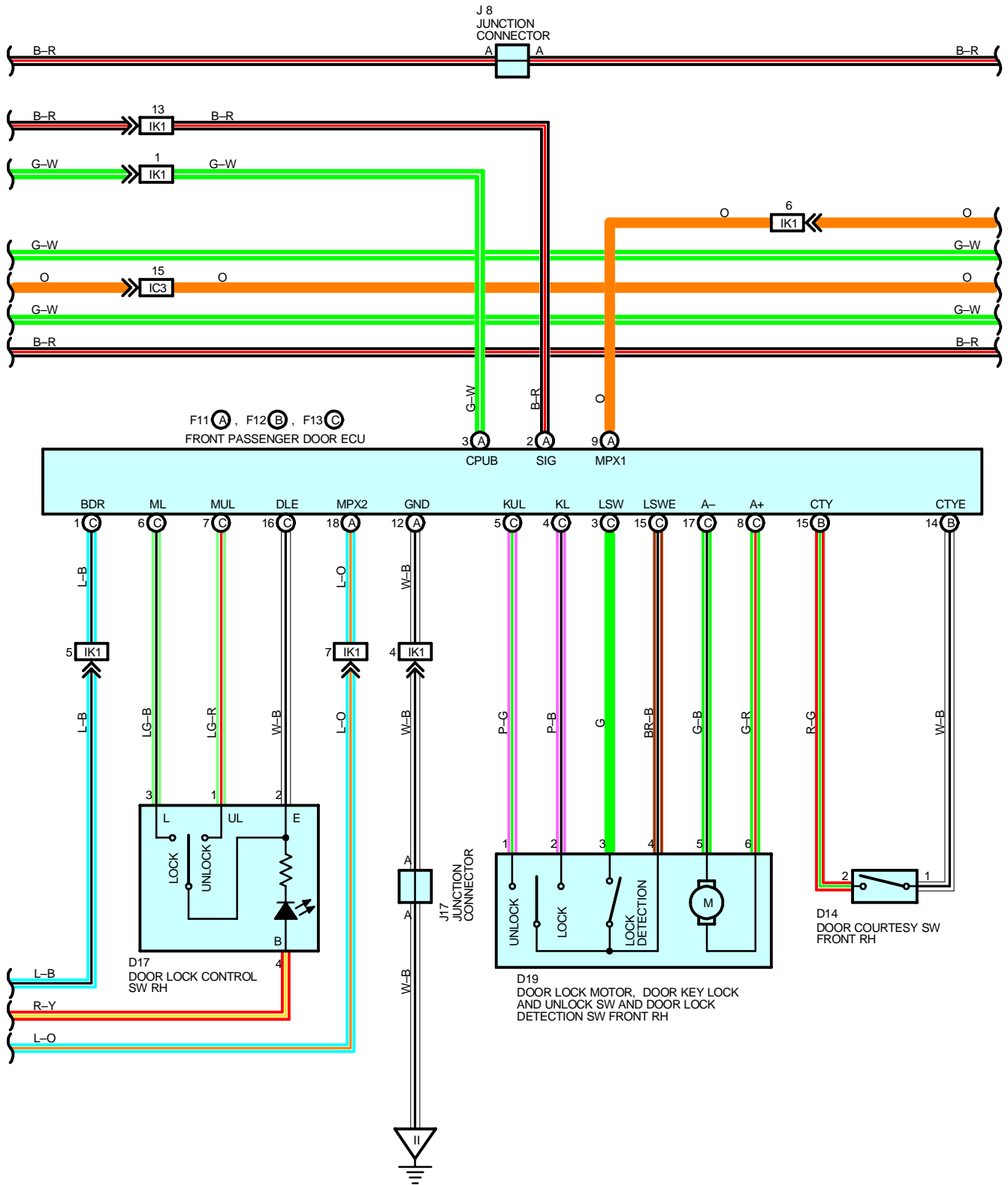

FROM POWER SOURCE SYSTEM (SEE PAGE 60)

* 5 : W/ DRIVING POSITION MEMORY
 * 6 : WO DRIVING POSITION MEMORY

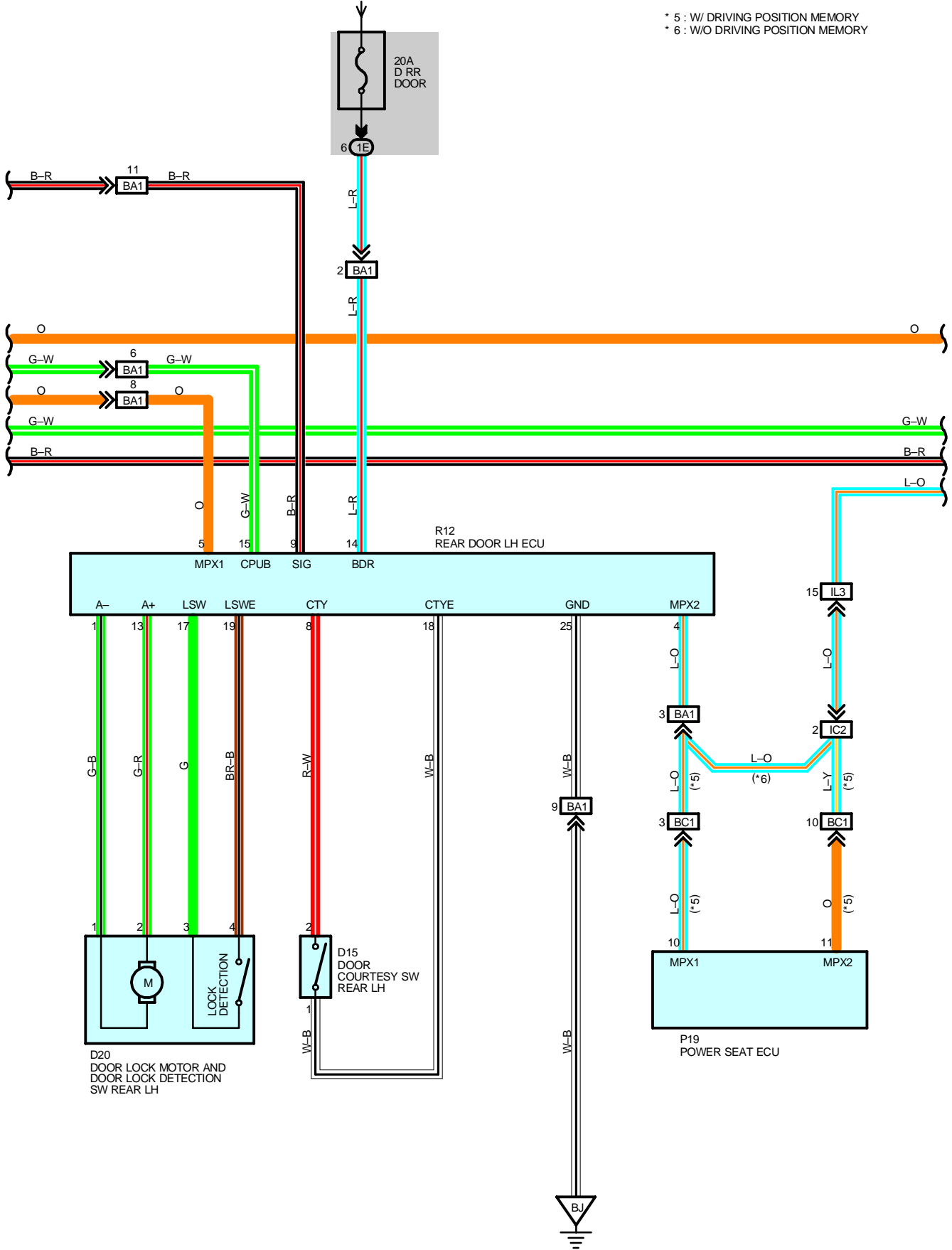

THEFT DETERRENT AND DOOR LOCK CONTROL

FROM POWER SOURCE SYSTEM (SEE PAGE 60)

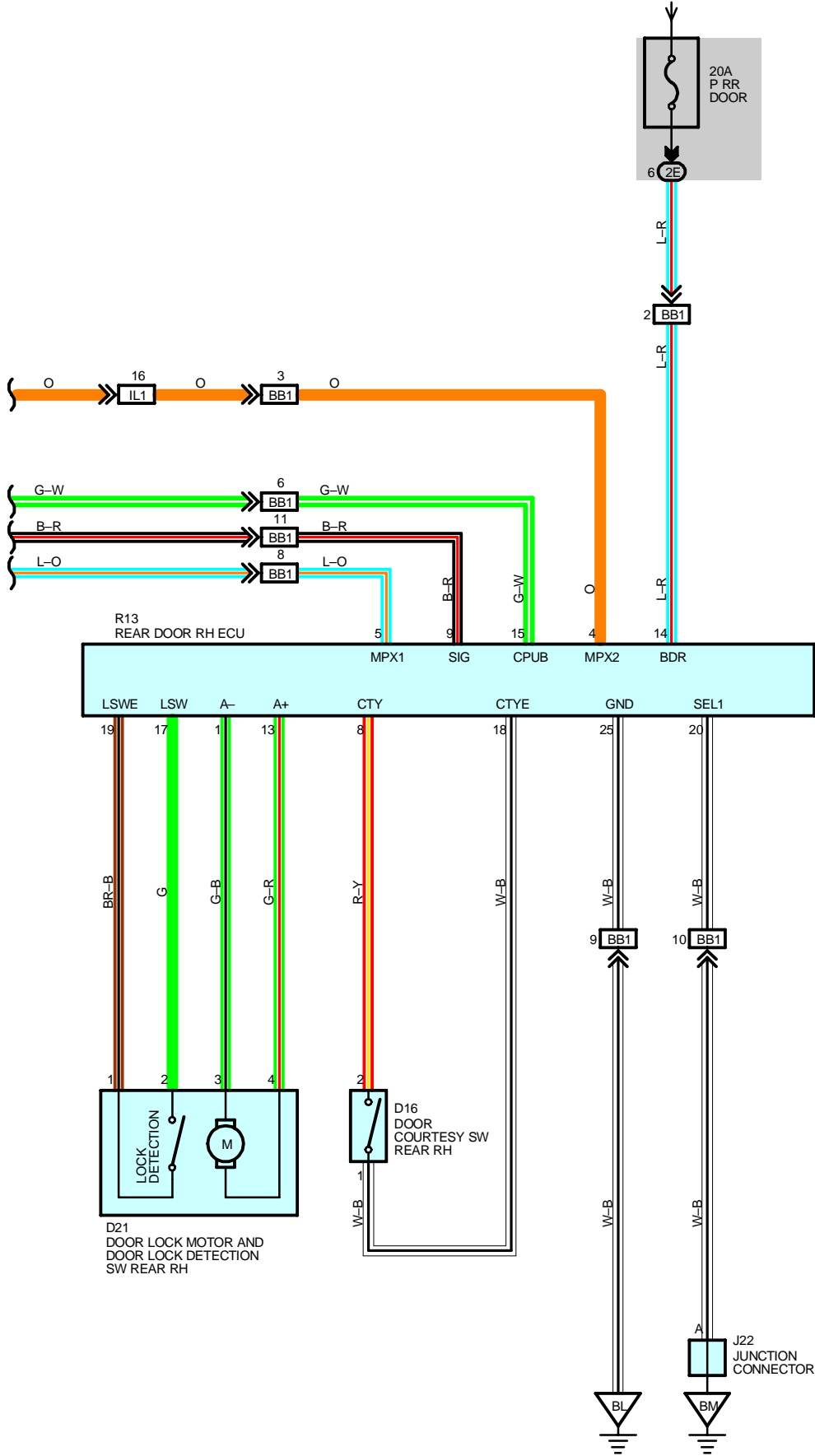

SYSTEM OUTLINE

1. MANUAL UNLOCK OPERATION

When the door lock control SW on the driver or front passenger seat is pressed to the unlock position, the signal is input to TERMINAL MUL of the driver door ECU or front passenger door ECU. Through communication control of the body ECU and door ECU etc. , the current flows from TERMINAL A- of the door ECU into the door lock motor to TERMINAL A+ of the door ECU to GROUND, to unlock the door.

2. MANUAL LOCK OPERATION

When the door lock control SW on the driver or front passenger seat is pressed to LOCK, signal is input to TERMINAL ML of the driver door ECU or front passenger door ECU. Through communication control of the body ECU and door ECU etc. , current flows from TERMINAL A+ of the door ECU to door lock motor to TERMINAL A- of the door ECU to GROUND, to lock the door.

3. DOOR KEY UNLOCK OPERATION

Unlock operation from driver door

When the door is unlocked once by the ignition key from the driver side, the signal from the door key lock and unlock SW in the door lock motor front LH is input to TERMINAL KUL of the driver door ECU. This signal activates the driver door ECU to flow the current from TERMINAL A+ of the driver door ECU into the door lock motor front LH to TERMINAL A+ of the driver door ECU to GROUND, to unlock only the driver door. Accordingly, if the second unlock operation is made within 3 sec. after the above unlock operation, all the doors are unlocked through communication control of the body ECU and door ECU etc.

Unlock operation from passenger door

When the door is unlocked by the ignition key from the front passenger side, the signal from the door key lock and unlock SW in the door lock motor front RH is input to TERMINAL KUL of the front passenger door ECU. Through communication control of the body ECU and door ECU etc. , the current flows from TERMINAL A- of the door ECU into the door lock motor front RH to TERMINAL A+ of the door ECU to GROUND, to unlock all the doors at once.

4. IGNITION KEY REMINDER OPERATION

When the door lock operation is made using the door knob with the ignition key remained inserted in the key cylinder and the door open, unlock operation is automatically made. Additionally, if lock operation is made with the door lock control SW or door key lock and unlock SW, unlock operation is automatically made after the lock operation has been completed.

THEFT DETERRENT AND DOOR LOCK CONTROL

SERVICE HINTS

L6 LUGGAGE COMPARTMENT DOOR KEY UNLOCK SW

1-2 : Closed with door lock cylinder unlocked with key

E9 ENGINE HOOD COURTESY SW

1-2 : Opened with engine hood open

L5 LUGGAGE COMPARTMENT DOOR COURTESY SW AND OPENER MOTOR

2-GROUND : Closed with luggage compartment door open

D13, D14, D15, D16 DOOR COURTESY SW FRONT LH, RH, REAR LH, RH

1-2 : Closed with door open

P11 DOOR LOCK CONTROL SW LH [POWER WINDOW MASTER SW]

5-16 : Closed with **LOCK** position

17-16 : Closed with **UNLOCK** position

D17 DOOR LOCK CONTROL SW RH

3-2 : Closed with **LOCK** position

1-2 : Closed with **UNLOCK** position

D18 DOOR LOCK MOTOR, DOOR KEY LOCK AND UNLOCK SW AND DOOR LOCK DETECTION SW FRONT LH

2-GROUND : Approx. 12 volts with door lock motor at lock operate

1-GROUND : Approx. 12 volts with door lock motor at unlock operate

5-3 : Closed with door lock cylinder locked with key

6-3 : Closed with door lock cylinder unlocked with key

D19 DOOR LOCK MOTOR, DOOR KEY LOCK AND UNLOCK SW AND DOOR LOCK DETECTION SW FRONT RH

6-GROUND : Approx. 12 volts with door lock motor at lock operate

5-GROUND : Approx. 12 volts with door lock motor at unlock operate

2-4 : Closed with door lock cylinder locked with key

1-4 : Closed with door lock cylinder unlocked with key

D20 DOOR LOCK MOTOR AND DOOR LOCK DETECTION SW REAR LH

2-GROUND : Approx. 12 volts with door lock motor at lock operate

1-GROUND : Approx. 12 volts with door lock motor at unlock operate

D21 DOOR LOCK MOTOR AND DOOR LOCK DETECTION SW REAR RH

4-GROUND : Approx. 12 volts with door lock motor at lock operate

3-GROUND : Approx. 12 volts with door lock motor at unlock operate

○ : PARTS LOCATION

Code	See Page	Code	See Page	Code	See Page
A13	40	D24	C 42	J17	41
B5	A 40	E5	D 38 (2JZ-GE)	J18	41
B6	A 40	E7	F 36 (1UZ-FE)	J20	42
C13	40	E9	36 (1UZ-FE)	J22	42
D8	42		38 (2JZ-GE)	L5	43
D13	42	F11	A 42	L6	43
D14	42	F12	B 42	M3	41
D15	42	F13	C 42	P11	43
D16	42	H18	40	P19	44
D17	42	J6	41	R7	41
D18	42	J7	41	R12	43
D19	42	J8	41	R13	43
D20	42	J10	41	T1	37 (1UZ-FE)
D21	42	J13	41		39 (2JZ-GE)
D22	A 42	J14	41	T5	41
D23	B 42	J15	41	W5	43

 : RELAY BLOCKS

Code	See Page	Relay Blocks (Relay Block Location)
1	22	Engine Room No.1 R/B (Engine Compartment Right)
2	23	Engine Room No.2 R/B (Engine Compartment Left)

 : JUNCTION BLOCK AND WIRE HARNESS CONNECTOR

Code	See Page	Junction Block and Wire Harness (Connector Location)
1E	26	Floor No.2 Wire and Driver Side J/B (Left Kick Panel)
1F	26	Cowl Wire and Driver Side J/B (Left Kick Panel)
1G	27	
1H		
1K	26	
2B	28	Engine Room Main Wire and Passenger Side J/B (Right Kick Panel)
2E	28	Floor No.1 Wire and Passenger Side J/B (Right Kick Panel)
2F	28	Cowl Wire and Passenger Side J/B (Right Kick Panel)
2G	29	
2H		

 : CONNECTOR JOINING WIRE HARNESS AND WIRE HARNESS

Code	See Page	Joining Wire Harness and Wire Harness (Connector Location)
IB1	50	Front Door LH Wire and Cowl Wire (Left Kick Panel)
IC1	50	Floor No.2 Wire and Cowl Wire (Left Kick Panel)
IC2		
IC3		
IE1	50	Instrument Panel Wire and Cowl Wire (Left Side of the Steering Column)
IE2		
II2	52	Engine Room Main Wire and Cowl Wire (Near the Passenger Side R/B)
IJ1	52	Instrument Panel Wire and Cowl Wire (Left Side of the Blower Unit)
IJ2		
IK1	52	Front Door RH Wire and Cowl Wire (Right Kick Panel)
IL1	52	Floor No.1 Wire and Cowl Wire (Right Kick Panel)
IL3		
BA1	54	Rear Door LH Wire and Floor No.2 Wire (Under the Center Pillar LH)
BB1	54	Rear Door RH Wire and Floor No.1 Wire (Under the Center Pillar RH)
BC1	56	Floor No.2 Wire and Front Seat LH Wire (Under the Driver's Seat)

 : GROUND POINTS

Code	See Page	Ground Points Location
EB	46 (1UZ-FE)	Left Fender
	48 (2JZ-GE)	
IF	50	Left Kick Panel
II	50	Right Side of the Cowl Panel
BJ	54	Rear Floor Partition Panel LH
BK	54	Quarter Panel LH
BL	54	Rear Floor Partition Panel RH
BM	54	Quarter Panel RH

 : SPLICE POINTS

Code	See Page	Wire Harness with Splice Points	Code	See Page	Wire Harness with Splice Points
I6	52	Cowl Wire			

THEFT DETERRENT AND DOOR LOCK CONTROL

A13

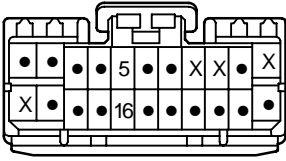

B5 (A)

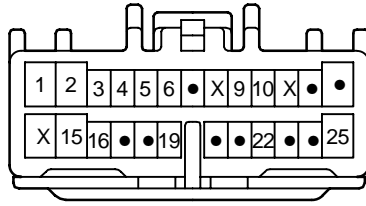

B6 (A)

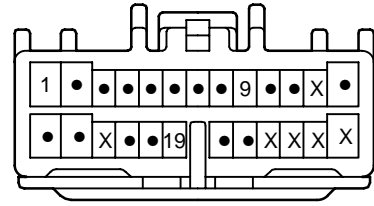

C13

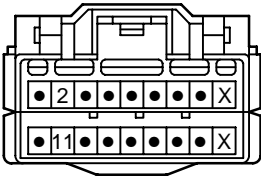

D8
GRAY

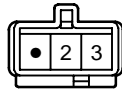

D13
GRAY

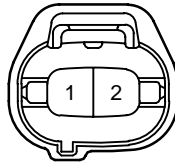

D14
GRAY

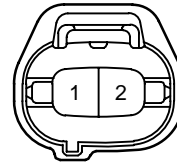

D15
GRAY

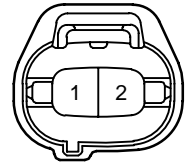

D16
GRAY

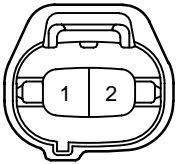

D17

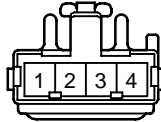

D18
BLACK

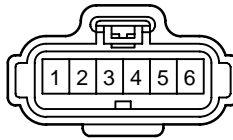

D19
BLACK

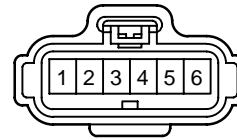

D20
BLACK



D21
BLACK

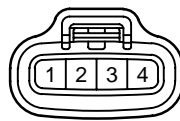

D22 (A)
GRAY

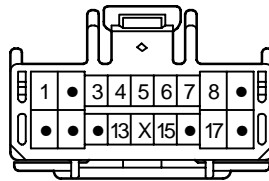

D23 (B)
GRAY

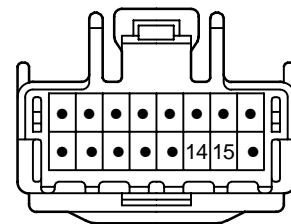

D24 (C)
GRAY

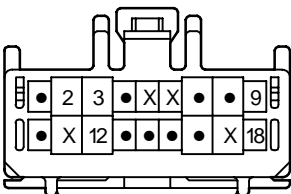

E5 (D)
(2JZ-GE)

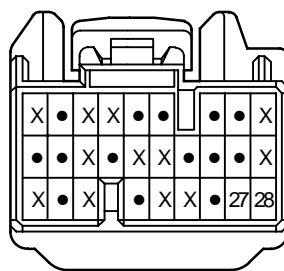

E7 (F)
(1UZ-FE)

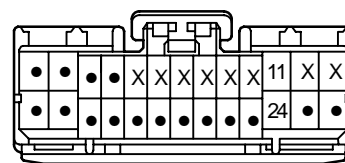

E9
BLACK



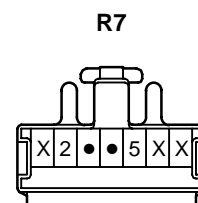
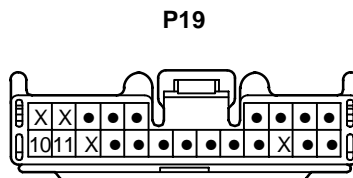
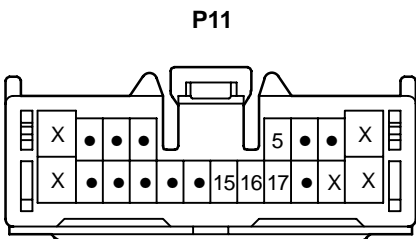
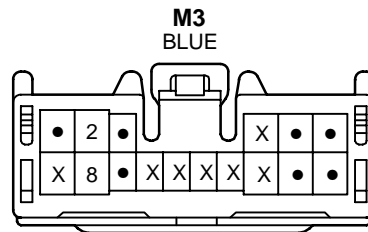
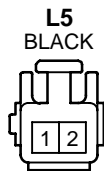
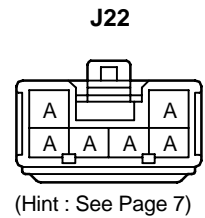
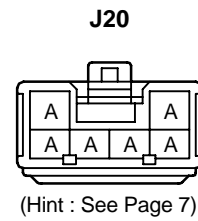
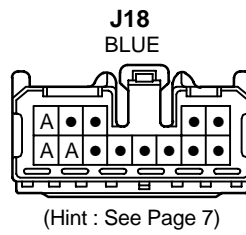
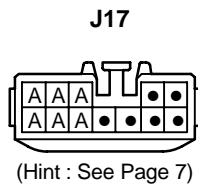
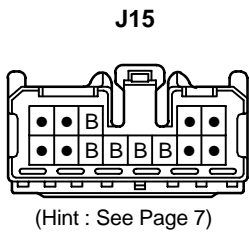
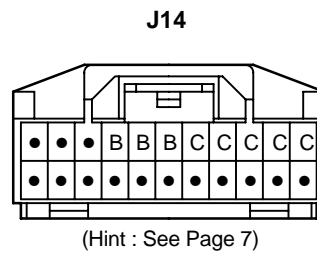
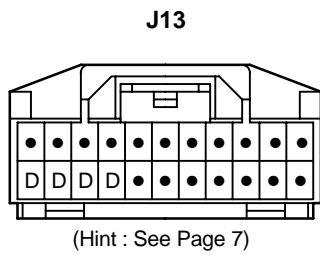
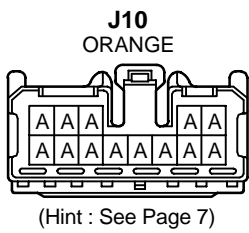
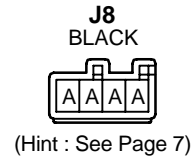
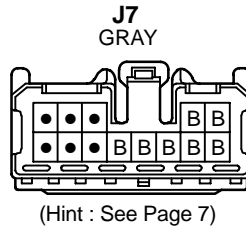
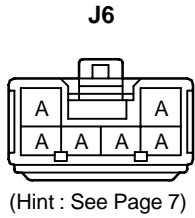
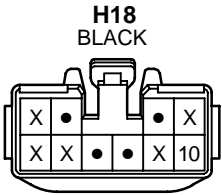
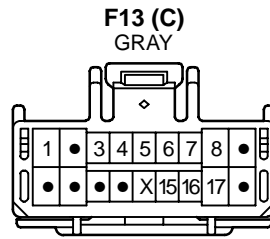
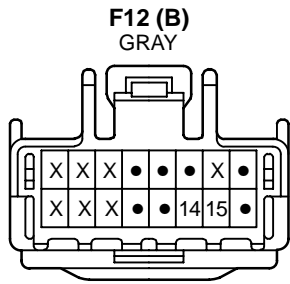
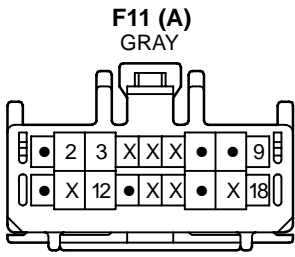

THEFT DETERRENT AND DOOR LOCK CONTROL

R12

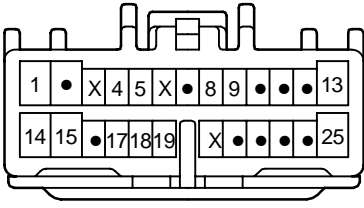

R13

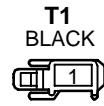
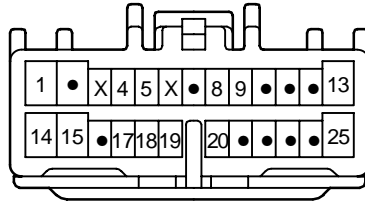

T5
GRAY

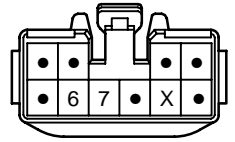

W5

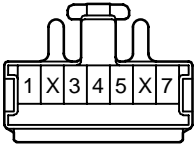

TURN SIGNAL AND HAZARD WARNING LIGHT

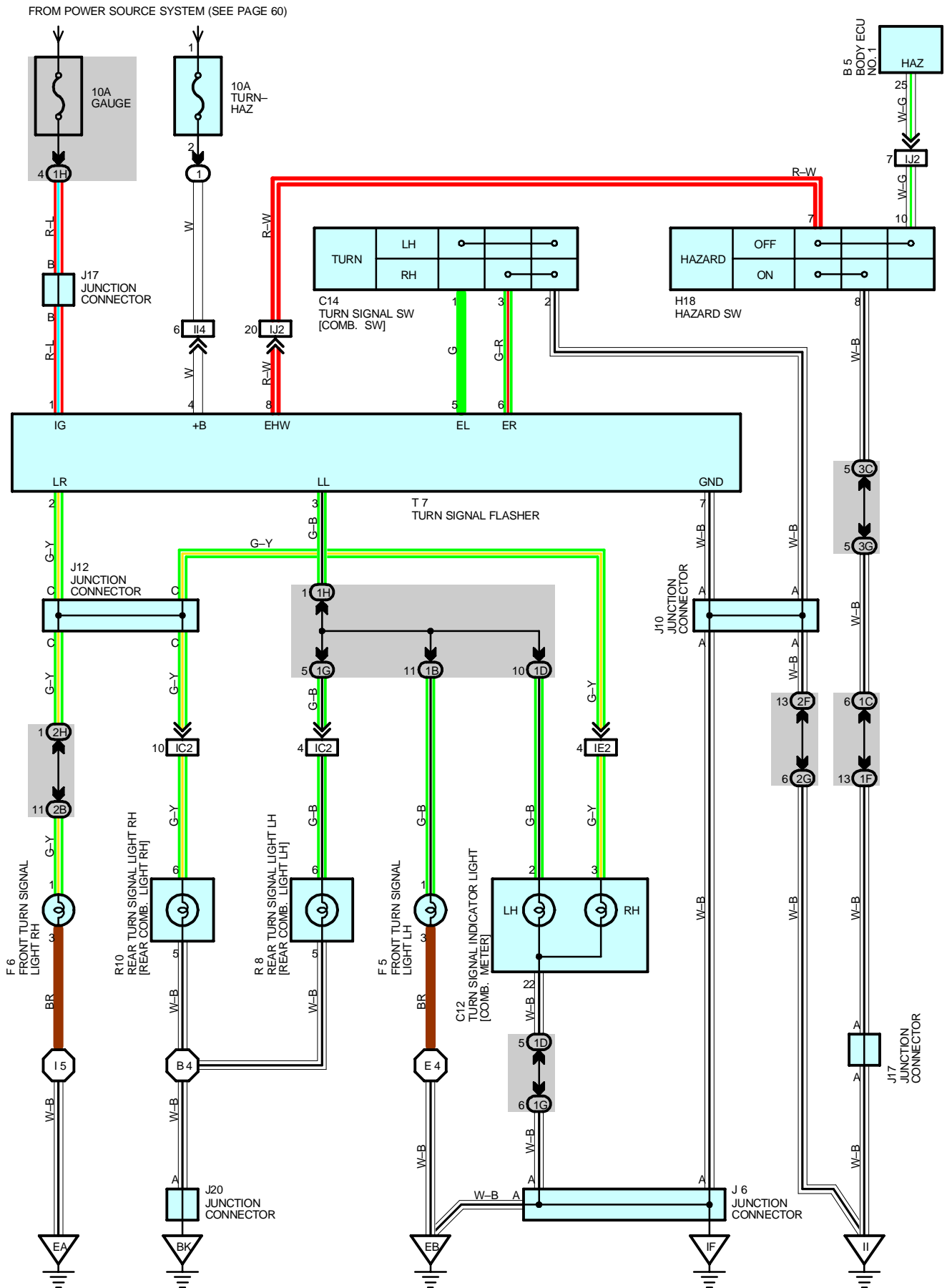

SERVICE HINTS**T7 TURN SIGNAL FLASHER**

4-GROUND : Always approx. 12 volts

1-GROUND : Approx. 12 volts with ignition SW at **ON** or **ST** position

7-GROUND : Always continuity

○ : PARTS LOCATION

Code	See Page	Code	See Page	Code	See Page
B 5	40	F6	38 (2JZ-GE)	J20	42
C12	40	H18	40	R8	43
C14	40	J6	41	R10	43
F5	36 (1UZ-FE)	J10	41	T7	41
	38 (2JZ-GE)	J12	41		
F6	36 (1UZ-FE)	J17	41		

○ : RELAY BLOCKS

Code	See Page	Relay Blocks (Relay Block Location)
1	22	Engine Room No.1 R/B (Engine Compartment Right)

○ : JUNCTION BLOCK AND WIRE HARNESS CONNECTOR

Code	See Page	Junction Block and Wire Harness (Connector Location)
1B	26	Cowl Wire and Driver Side J/B (Left Kick Panel)
1C	26	Instrument Panel Wire and Driver Side J/B (Left Kick Panel)
1D		
1F	26	Cowl Wire and Driver Side J/B (Left Kick Panel)
1G	27	
1H		
2B	28	Engine Room Main Wire and Passenger Side J/B (Right Kick Panel)
2F	28	Cowl Wire and Passenger Side J/B (Right Kick Panel)
2G	29	
2H		
3C	30	Instrument Panel Wire and Instrument Panel J/B (Instrument Panel Reinforcement Center)
3G	31	

□ : CONNECTOR JOINING WIRE HARNESS AND WIRE HARNESS

Code	See Page	Joining Wire Harness and Wire Harness (Connector Location)
IC2	50	Floor No.2 Wire and Cowl Wire (Left Kick Panel)
IE2	50	Instrument Panel Wire and Cowl Wire (Left Side of the Steering Column)
II4	52	Engine Room Main Wire and Cowl Wire (Near the Passenger Side R/B)
IJ2	52	Instrument Panel Wire and Cowl Wire (Left Side of the Blower Unit)

▽ : GROUND POINTS

Code	See Page	Ground Points Location
EA	46 (1UZ-FE)	Right Fender
	48 (2JZ-GE)	
EB	46 (1UZ-FE)	Left Fender
	48 (2JZ-GE)	
IF	50	Left Kick Panel
II	50	Right Side of the Cowl Panel
BK	54	Quarter Panel LH

TURN SIGNAL AND HAZARD WARNING LIGHT

 : SPLICE POINTS

Code	See Page	Wire Harness with Splice Points	Code	See Page	Wire Harness with Splice Points
15	52	Engine Room Main Wire	B4	54	Floor No.2 Wire

B5

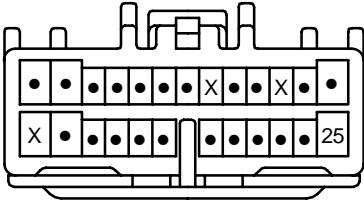

C12

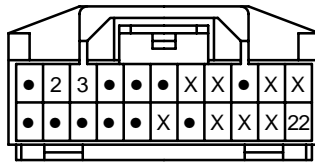

C14

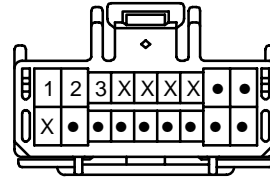

F5
GRAY

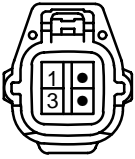

F6
GRAY

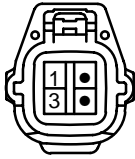

H18
BLACK

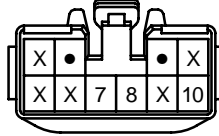

J6

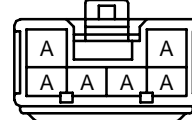

(Hint : See Page 7)

J10
ORANGE

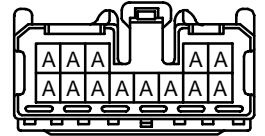

(Hint : See Page 7)

J12
GRAY

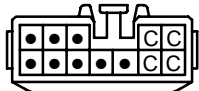

(Hint : See Page 7)

J17



(Hint : See Page 7)

J20

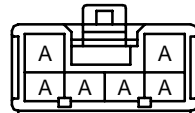

(Hint : See Page 7)

R8

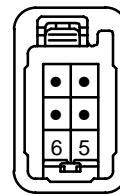

R10

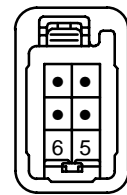

T7
BLACK



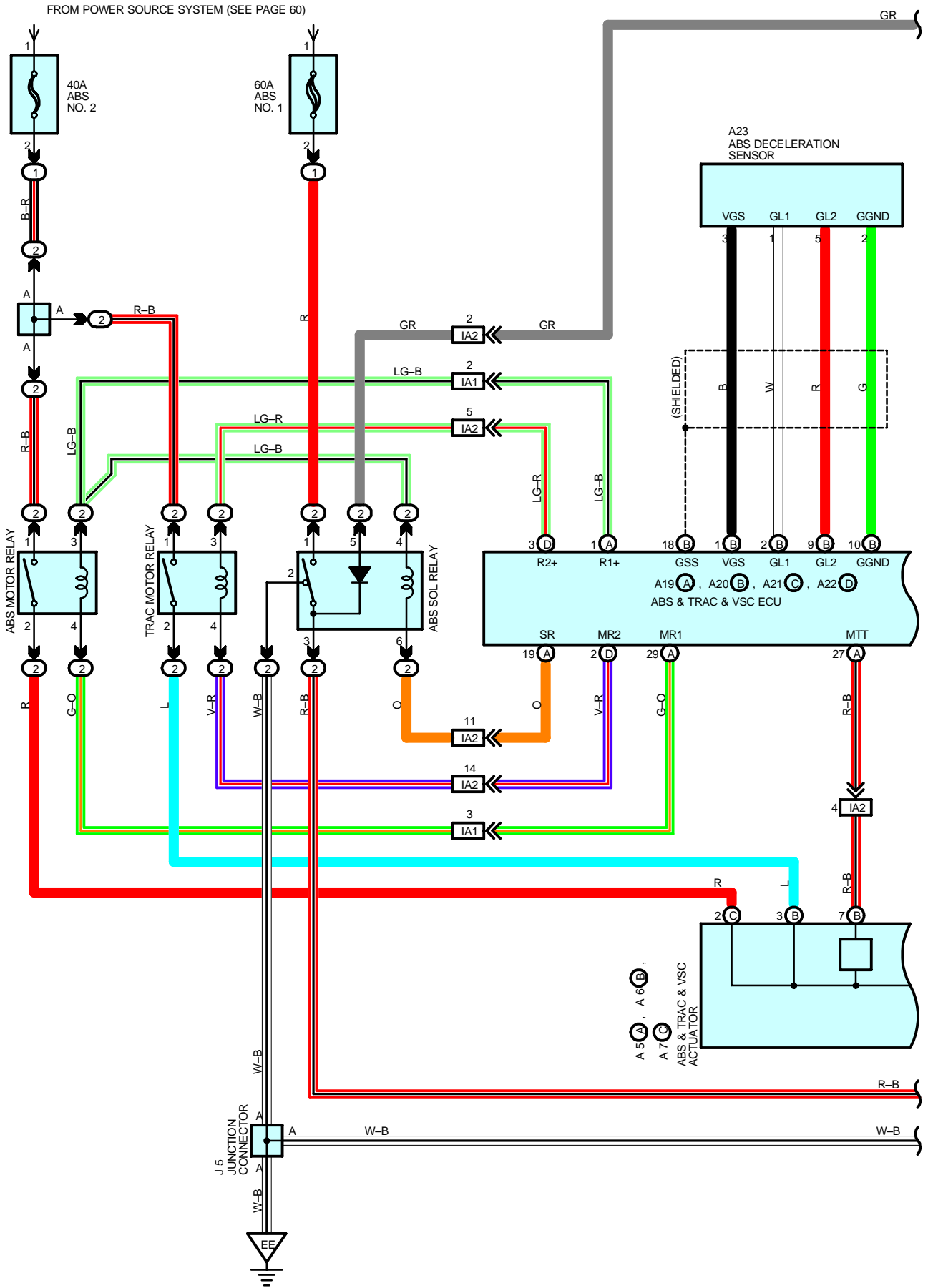

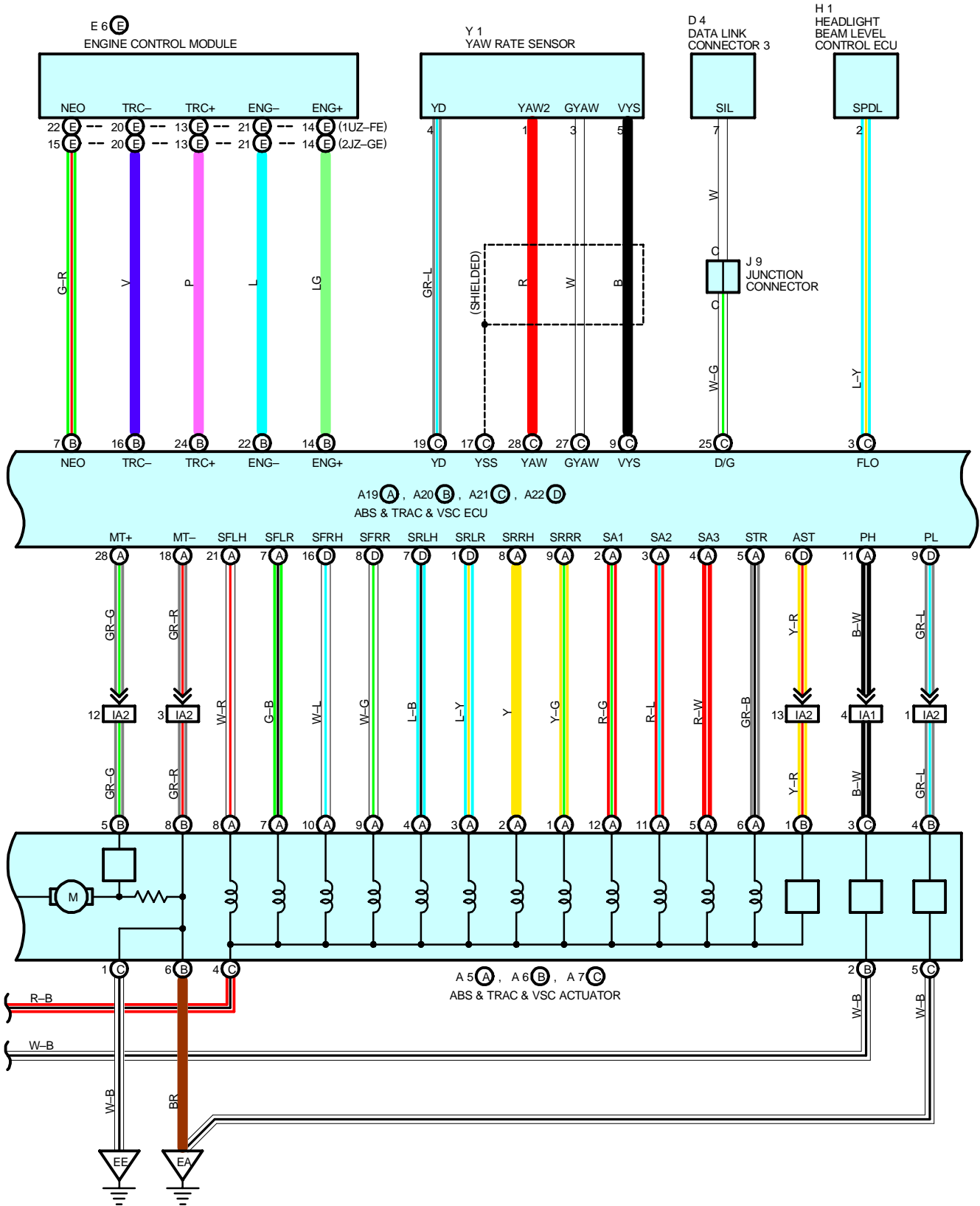



FROM POWER SOURCE SYSTEM (SEE PAGE 60)

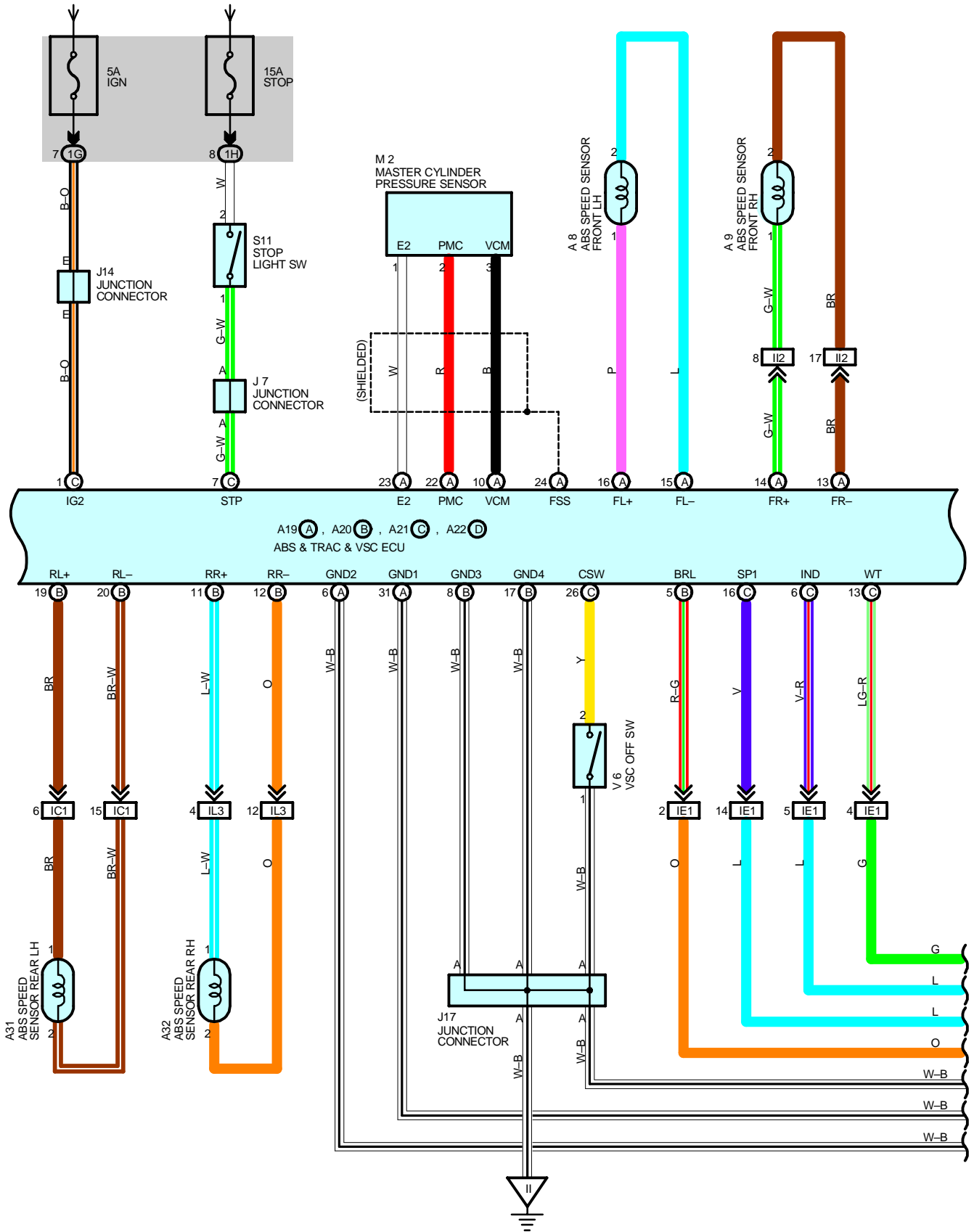

FROM POWER SOURCE SYSTEM (SEE PAGE 60)

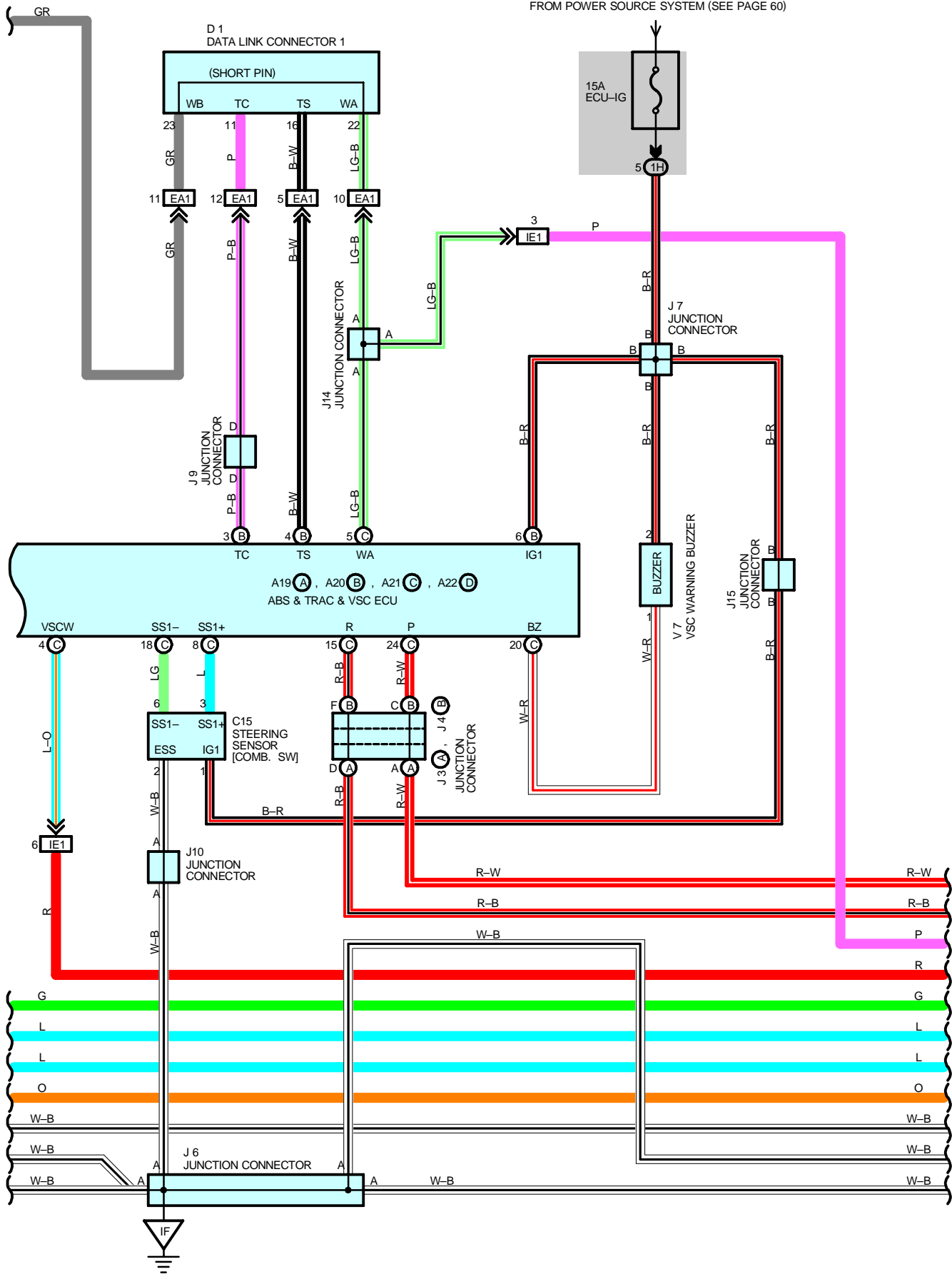

FROM POWER SOURCE SYSTEM (SEE PAGE 60)

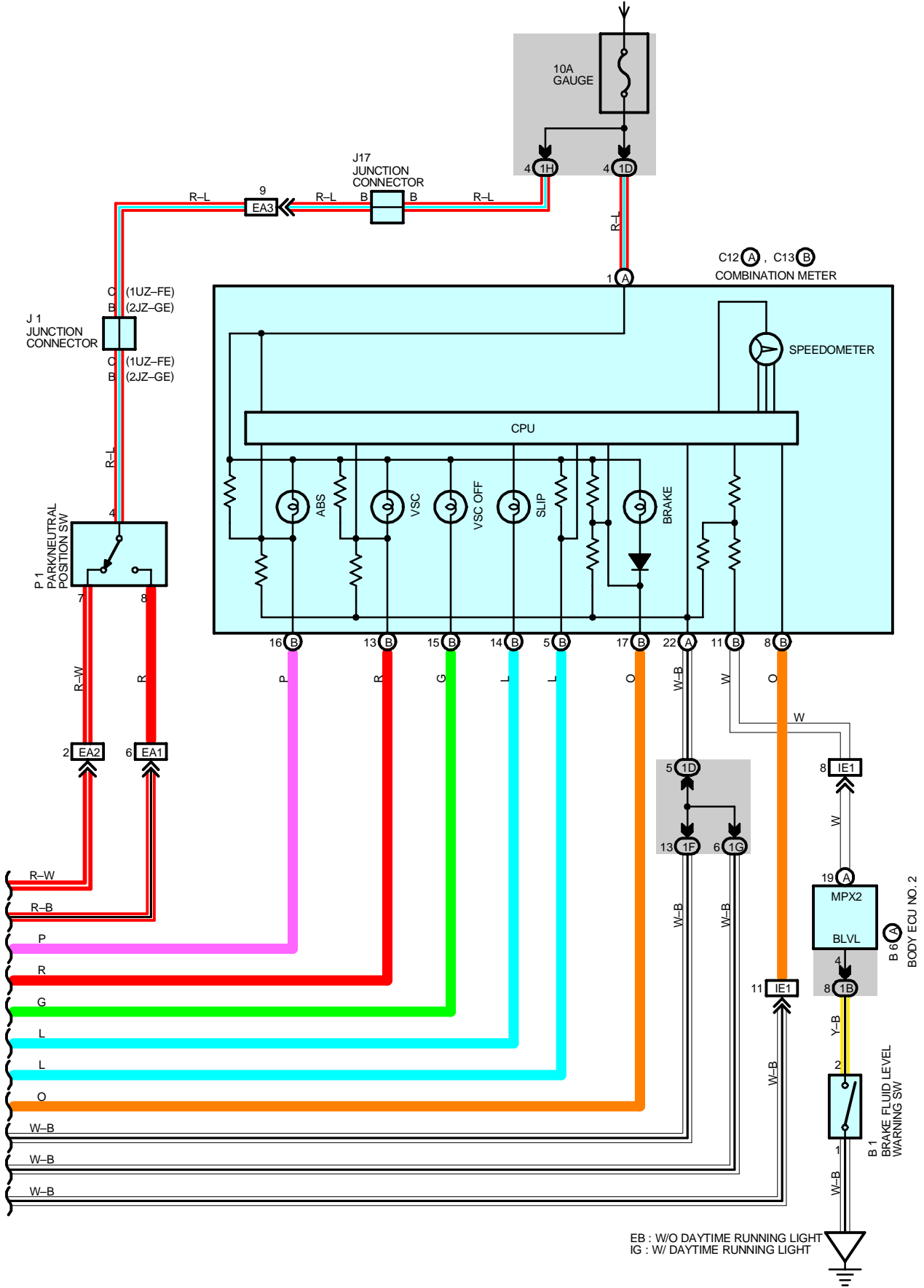

SYSTEM OUTLINE

1. ABS OPERATION

If the brake pedal is depressed suddenly, the ABS controls the hydraulic pressure of the wheel cylinders for all the four wheels to automatically avoid wheel locking and ensure the directional and steering stability of the vehicle. If the brake pedal is depressed suddenly, the ABS & TRAC & VSC ECU controls the solenoids in the actuators using the signals from the sensors to move the brake fluid to the reservoir in order to release the braking pressure applied to the wheel cylinder. If the ABS & TRAC & VSC ECU detects that the fluid pressure in the wheel cylinder is insufficient, the ECU controls the solenoids in the actuators to increase the braking pressure.

2. TRACTION CONTROL OPERATION

The traction control system controls the engine torque, the hydraulic pressure of the driving wheel cylinders, slipping of the wheels which may occur at start or acceleration of the vehicle, to ensure an optimal driving power and vehicle stability corresponding to the road conditions.

3. VSC OPERATION

Unexpected road conditions, vehicle speed, emergency situation, and any other external factors may cause large under- or over-steering of the vehicle. If this occurs, the VSC system automatically controls the engine power and wheel brakes to reduce the under- or over-steering.

To reduce large over-steering :

If the VSC system determines that the over-steering is large, it activates the brakes for the outer turning wheels depending on the degree of the over-steering to produce the moment toward the outside of the vehicle and reduce the over-steering.

To reduce large under-steering :

If the VSC system determines that the under-steering is large, it controls the engine power and activates the rear wheel brakes to reduce the under-steering.

VSC OFF SW

The VSC OFF SW is used to stop the VSC function. After the engine is started, the VSC system is stopped (turned off) and the VSC OFF indicator light lights up. When the VSC OFF SW is pressed again, the VSC system enters the stand-by mode. If the engine is stopped and restarted, the VSC system enters the stand-by mode regardless of the VSC OFF SW.

VSC indicator light

If an error occurs in the VSC system, the VSC indicator lights up to warn the driver.

4. MUTUAL SYSTEM CONTROL

To efficiently operate the VSC system at its optimal level, the VSC system and other control systems are mutually controlled while the VSC system is being operated.

Engine throttle control

The engine power does not interfere with the VSC brake control by controlling the opening of the throttle and reducing the engine output.

Engine control and electronically controlled transmission control

The strong braking force does not interfere with the braking force control of the VSC system by turning off the accel. and reducing changes in the driving torque at shift-down.

VSC system operation indication

The slip indicator light flashes and the buzzer sounds intermittently to warn the driver that the current road is slippery, while the VSC system is being operated.

5. FAIL SAFE FUNCTION

If an error occurs in the ABS & TRAC & VSC ECU, sensor signals, and/or actuators, the ABS & TRAC & VSC ECU inhibits the brake actuator control and inputs the error signal to the engine control module. According to the error signal, the brake actuator turns off the solenoid and the engine control module rejects any electronically controlled throttle open request from the VSC system. As a result, the vehicle functions without the ABS, TRAC, and VSC systems.

SERVICE HINTS

A19 (A), A20 (B), A21 (C) ABS & TRAC & VSC ECU

- (C) 1-GROUND : Approx. 12 volts with ignition SW at **ON** or **ST** position
- (B) 6-GROUND : Approx. 12 volts with ignition SW at **ON** or **ST** position
- (C) 7-GROUND : Approx. 12 volts with stop light SW on
- (A) 6, (A) 31, (B) 8, (B) 17-GROUND : Always continuity

A8, A9 ABS SPEED SENSOR FRONT LH, RH

- 1-2 : Approx. 1.60 kΩ (20°C, 68°F)

A31, A32 ABS SPEED SENSOR REAR LH, RH

- 1-2 : Approx. 1.10 kΩ (20°C, 68°F)

○ : PARTS LOCATION

Code		See Page	Code		See Page	Code		See Page
A5	A	36 (1UZ-FE)	B1		38 (2JZ-GE)	J5	37 (1UZ-FE)	
		38 (2JZ-GE)	B6	A	40		39 (2JZ-GE)	
A6	B	36 (1UZ-FE)	C12	A	40	J6	41	
		38 (2JZ-GE)	C13	B	40	J7	41	
A7	C	36 (1UZ-FE)	C15		40	J9	41	
		38 (2JZ-GE)	D1		36 (1UZ-FE)	J10	41	
A8	36 (1UZ-FE)	D4			38 (2JZ-GE)	J14	41	
	38 (2JZ-GE)			40	J15	41		
A9		36 (1UZ-FE)	E6	E	36 (1UZ-FE)	J17	41	
		38 (2JZ-GE)			38 (2JZ-GE)			
A19	A	40	H1		36 (1UZ-FE)	M2	37 (1UZ-FE)	
A20	B	40			38 (2JZ-GE)		39 (2JZ-GE)	
A21	C	40	J1		37 (1UZ-FE)	P1	37 (1UZ-FE)	
A22	D	40			39 (2JZ-GE)		39 (2JZ-GE)	
A23		40	J3	A	37 (1UZ-FE)	V6	41	
A31		42			39 (2JZ-GE)		V7	41
A32		42	J4	B	37 (1UZ-FE)	Y1	41	
B1		36 (1UZ-FE)			39 (2JZ-GE)			

○ : RELAY BLOCKS

Code	See Page	Relay Blocks (Relay Block Location)
1	22	Engine Room No.1 R/B (Engine Compartment Right)
2	23	Engine Room No.2 R/B (Engine Compartment Left)

○ : JUNCTION BLOCK AND WIRE HARNESS CONNECTOR

Code	See Page	Junction Block and Wire Harness (Connector Location)
1B	26	Cowl Wire and Driver Side J/B (Left Kick Panel)
1D	26	Instrument Panel Wire and Driver Side J/B (Left Kick Panel)
1F	26	Cowl Wire and Driver Side J/B (Left Kick Panel)
1G	27	
1H		

□ : CONNECTOR JOINING WIRE HARNESS AND WIRE HARNESS

Code	See Page	Joining Wire Harness and Wire Harness (Connector Location)
EA1	46 (1UZ-FE)	Engine Wire and Cowl Wire (Inside of the ECU Box)
	48 (2JZ-GE)	
EA2	46 (1UZ-FE)	
	48 (2JZ-GE)	
EA3	46 (1UZ-FE)	
	48 (2JZ-GE)	
IA1	50	Engine Room Main Wire and Cowl Wire (Near the Driver Side J/B)
IA2		
IC1	50	Floor No.2 Wire and Cowl Wire (Left Kick Panel)
IE1	50	Instrument Panel Wire and Cowl Wire (Left Side of the Steering Column)
II2	52	Engine Room Main Wire and Cowl Wire (Near the Passenger Side R/B)
IL3	52	Floor No.1 Wire and Cowl Wire (Right Kick Panel)

▽ : GROUND POINTS

Code	See Page	Ground Points Location
EA	46 (1UZ-FE)	Right Fender
	48 (2JZ-GE)	
EB	46 (1UZ-FE)	Left Fender
	48 (2JZ-GE)	
EE	46 (1UZ-FE)	Under the ABS & TRAC & VSC Actuator
	48 (2JZ-GE)	
IF	50	Left Kick Panel
IG	50	Left Side of the Cowl Panel
II	50	Right Side of the Cowl Panel

A5 (A)
BLACK

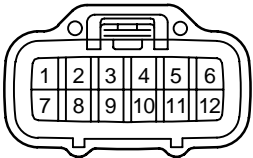

A6 (B)
BLACK

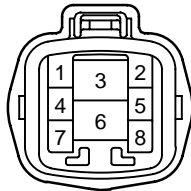

A7 (C)
BLACK

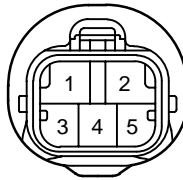

A8
GRAY

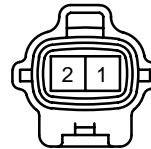

A9
GRAY



A19 (A)

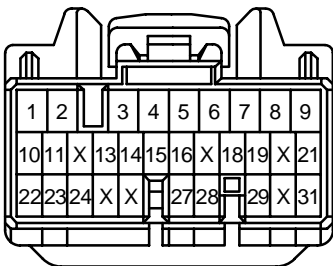

A20 (B)

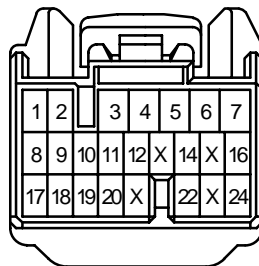

A21 (C)

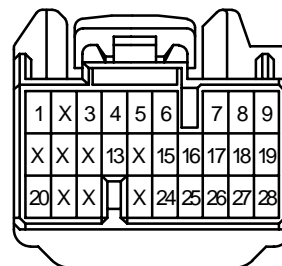

A22 (D)

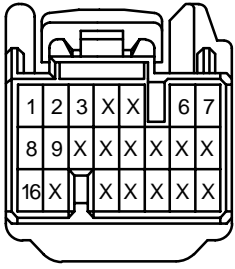

A23
BLACK

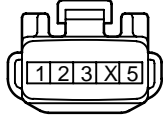

A31



A32



B1
GRAY



B6 (A)

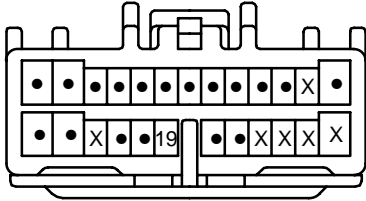

C12 (A)

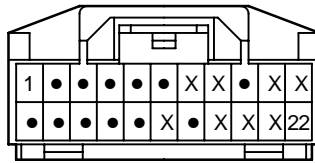

C13 (B)

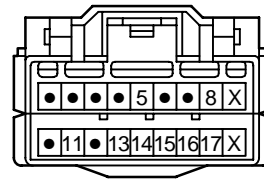

C15

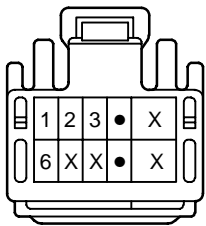

D1
(1UZ-FE) BLACK

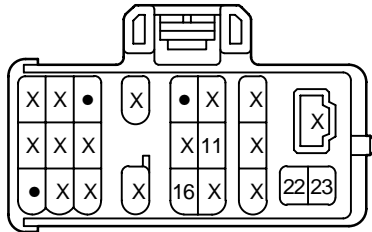

D1
(2JZ-GE) BLACK

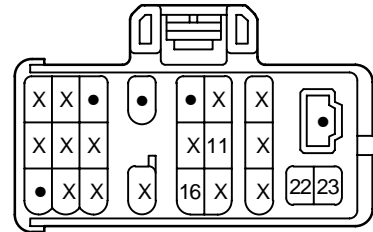

D4

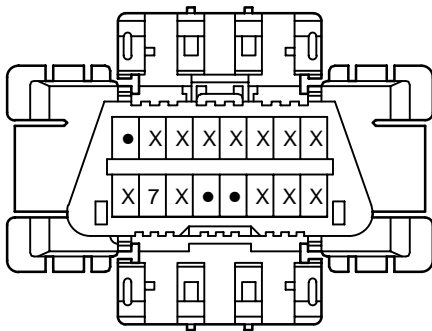

E6 (E)
(1UZ-FE)

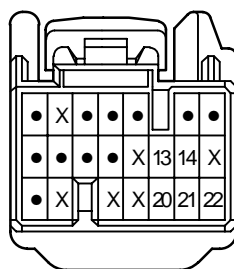

E6 (E)
(2JZ-GE)

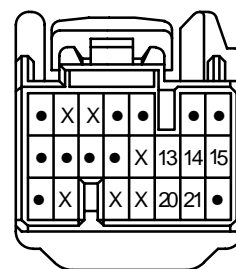

H1
GRAY

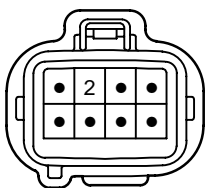

J1
(1UZ-FE) GRAY

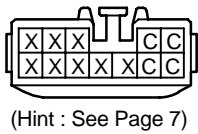

(Hint : See Page 7)

J1
(2JZ-GE) BLACK

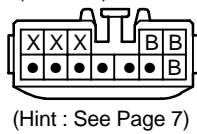

(Hint : See Page 7)

J3 (A)

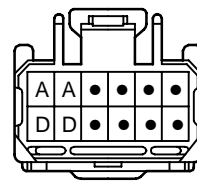

(Hint : See Page 7)

J4 (B)

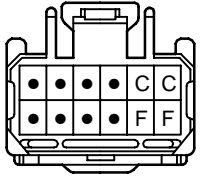

(Hint : See Page 7)

J5
BLUE



(Hint : See Page 7)

J6

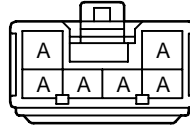

(Hint : See Page 7)

J7
GRAY

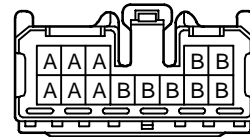

(Hint : See Page 7)

J9
(1UZ-FE)

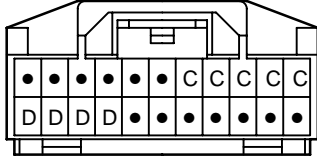

(Hint : See Page 7)

J9
(2JZ-GE)

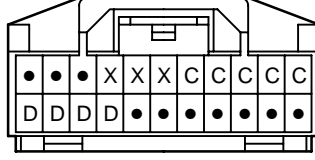

(Hint : See Page 7)

J10
ORANGE

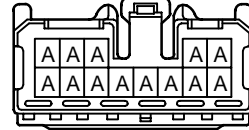

(Hint : See Page 7)

J14

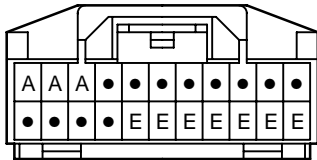

(Hint : See Page 7)

J15

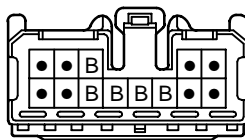

(Hint : See Page 7)

J17



(Hint : See Page 7)

M2
BLACK

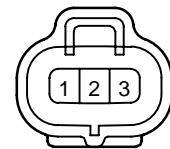

P1
GRAY

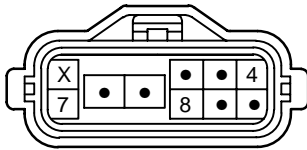

S11
BLUE

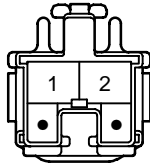

V6

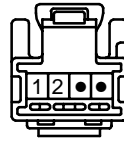

V7
BLACK

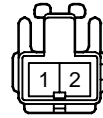

Y1
BLACK

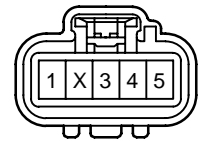

MEMO

WIPER AND WASHER

- * 1 : W/O DAYTIME RUNNING LIGHT
- * 2 : W/ DAYTIME RUNNING LIGHT

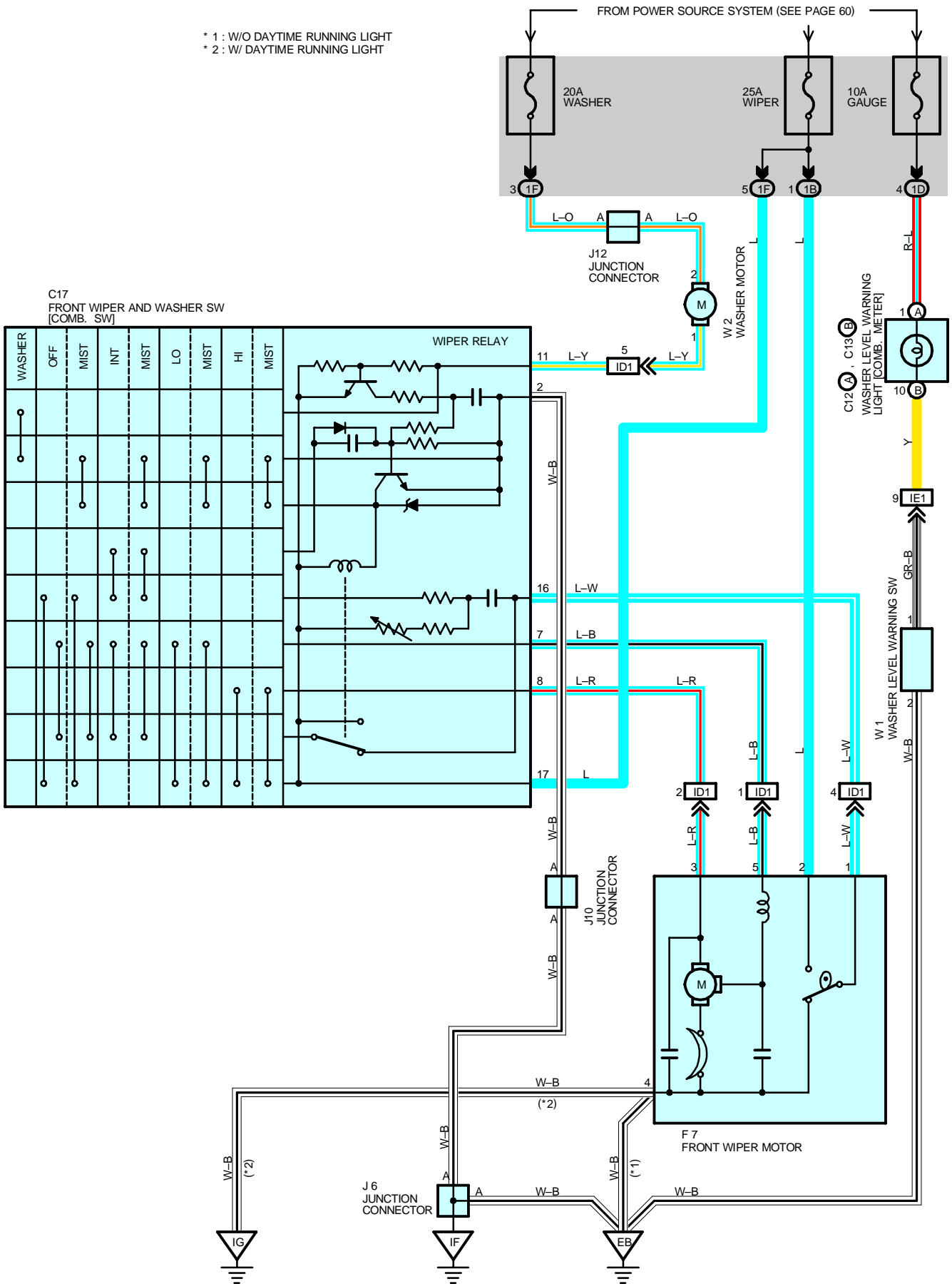

SYSTEM OUTLINE

With the ignition SW turned on, the current flows to TERMINAL 17 of the front wiper and washer SW, and TERMINAL 2 of the front wiper motor through the WIPER fuse, TERMINAL 2 of washer motor through the WASHER fuse.

1. LOW SPEED POSITION

With wiper SW turned to LO position, the current flows from TERMINAL 17 of the front wiper and washer SW to TERMINAL 7 to TERMINAL 5 of the front wiper motor to TERMINAL 4 to GROUND and causes the front wiper motor to run at low speed.

2. HIGH SPEED POSITION

With wiper SW turned to HI position, the current flows from TERMINAL 17 of the front wiper and washer SW to TERMINAL 8 to TERMINAL 3 of the front wiper motor to TERMINAL 4 to GROUND and causes the front wiper motor to run at high speed.

3. INT POSITION

With wiper SW turned to INT position, the relay operates and the current which is connected by relay function flows from TERMINAL 17 of the front wiper and washer SW to TERMINAL 2 to GROUND. This flow of current operates the intermittent circuit and the current flows from TERMINAL 17 of the front wiper and washer SW to TERMINAL 7 to TERMINAL 5 of the front wiper motor to TERMINAL 4 to GROUND and operates the wiper.

The intermittent operation is controlled by the charge/discharge function of the condenser installed in the relay, and the intermittent time is controlled by a time control SW to change the charging time of the condenser.

4. MIST POSITION

With wiper SW turn MIST position, the current flows from TERMINAL 17 of the front wiper and washer SW to TERMINAL 7 to TERMINAL 5 of the wiper motor to TERMINAL 4 to GROUND and causes the wiper motor to run at low speed.

5. WASHER CONTINUOUS OPERATION

With washer SW turned to on, the current flows from TERMINAL 2 of the washer motor to TERMINAL 1 to TERMINAL 11 of the front wiper and washer SW to TERMINAL 2 to GROUND and causes to the washer motor to run, and the window washer emits a water spray. This causes the current to flow to washer continuous operation circuit in TERMINAL 17 of the front wiper and washer SW to TERMINAL 7 to TERMINAL 5 of the front wiper motor to TERMINAL 4 to GROUND and operates the wiper.

SERVICE HINTS

C17 FRONT WIPER AND WASHER SW [COMB. SW]

2-GROUND : Always continuity

17-GROUND : Approx. 12 volts with the ignition SW at **ON** or **ST** position

7-GROUND : Approx. 12 volts with the front wiper and washer SW at **LO** position

Approx. 12 volts 2 to 12 seconds intermittently with the front wiper and washer SW at **INT** position

16-GROUND : Approx. 12 volts with the ignition SW on unless the front wiper motor at **STOP** position

8-GROUND : Approx. 12 volts with the front wiper and washer SW at **HI** position

F7 FRONT WIPER MOTOR

2-1 : Closed unless the wiper motor at **STOP** position

○ : PARTS LOCATION

Code	See Page	Code	See Page	Code	See Page	
C12	A	40	F7	38 (2JZ-GE)	W1	37 (1UZ-FE)
C13	B	40	J6	41		39 (2JZ-GE)
C17		40	J10	41	W2	37 (1UZ-FE)
F7		36 (1UZ-FE)	J12	41		39 (2JZ-GE)

○ : JUNCTION BLOCK AND WIRE HARNESS CONNECTOR

Code	See Page	Junction Block and Wire Harness (Connector Location)
1B	26	Cowl Wire and Driver Side J/B (Left Kick Panel)
1D	26	Instrument Panel Wire and Driver Side J/B (Left Kick Panel)
1F	26	Cowl Wire and Driver Side J/B (Left Kick Panel)

□ : CONNECTOR JOINING WIRE HARNESS AND WIRE HARNESS

Code	See Page	Joining Wire Harness and Wire Harness (Connector Location)
ID1	50	Cowl Wire and Cowl Wire (Left Side of the Instrument Panel Reinforcement)
IE1	50	Instrument Panel Wire and Cowl Wire (Left Side of the Steering Column)

WIPER AND WASHER

▽ : GROUND POINTS

Code	See Page	Ground Points Location
EB	46 (1UZ-FE)	Left Fender
	48 (2JZ-GE)	
IF	50	Left Kick Panel
IG	50	Left Side of the Cowl Panel

C12 (A)

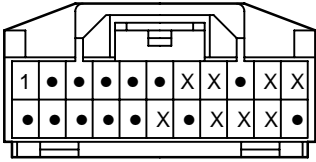

C13 (B)

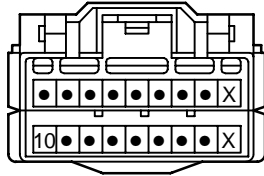

**C17
BLACK**

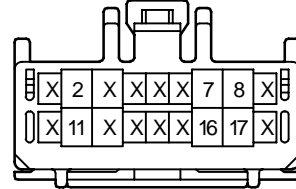

**F7
GRAY**

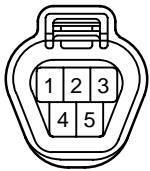

J6

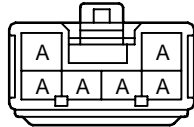

(Hint : See Page 7)

**J10
ORANGE**

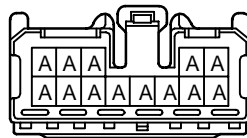

(Hint : See Page 7)

**J12
GRAY**

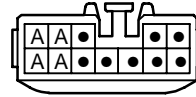

(Hint : See Page 7)

**W1
BLACK**

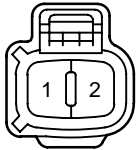

**W2
BLACK**

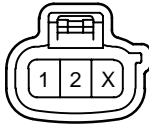

WIRELESS DOOR LOCK CONTROL

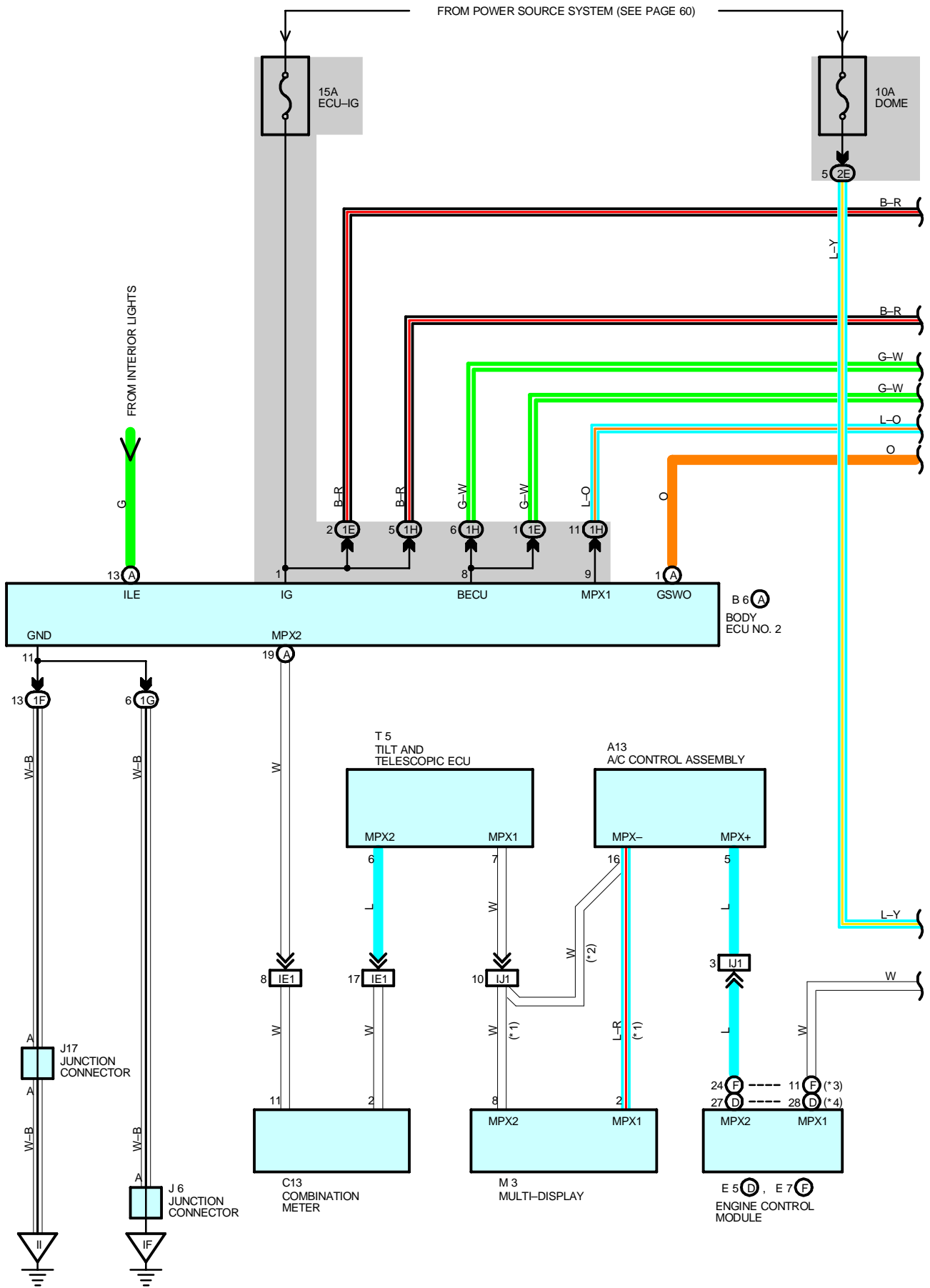

WIRELESS DOOR LOCK CONTROL

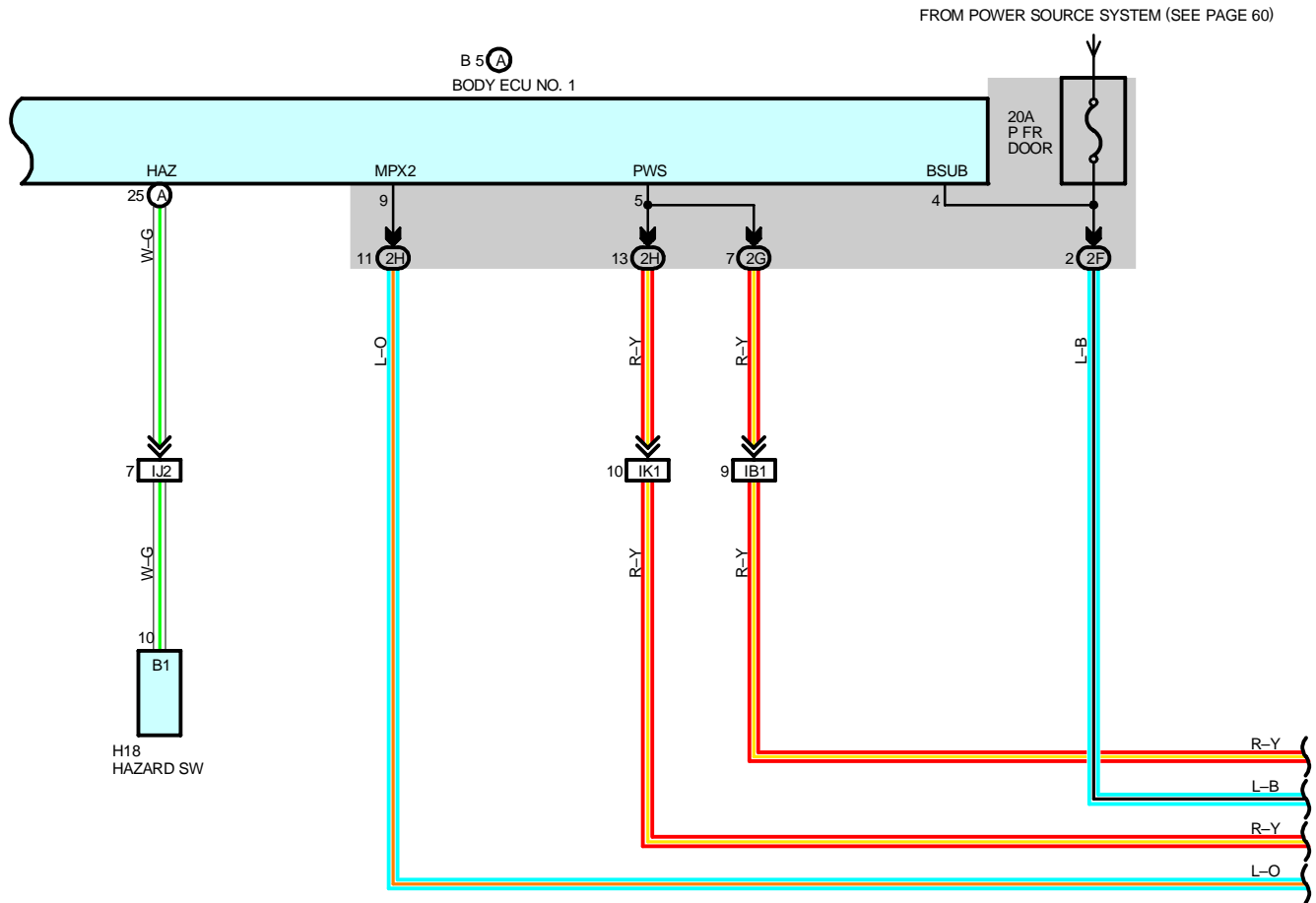
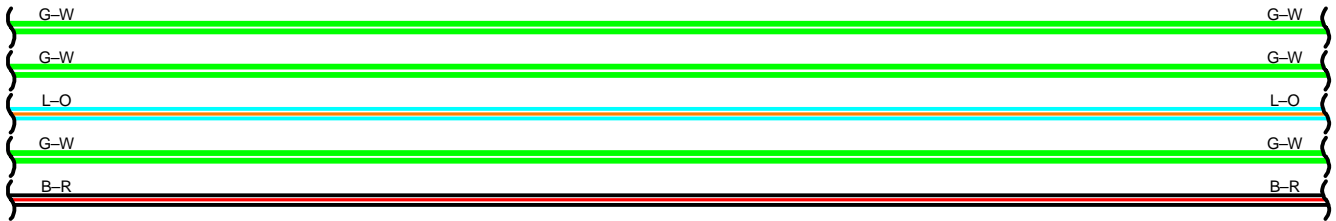
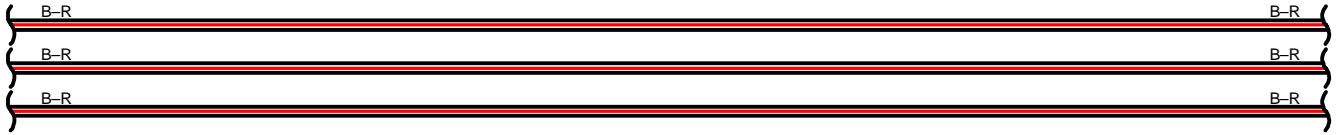

FROM POWER SOURCE SYSTEM (SEE PAGE 60)

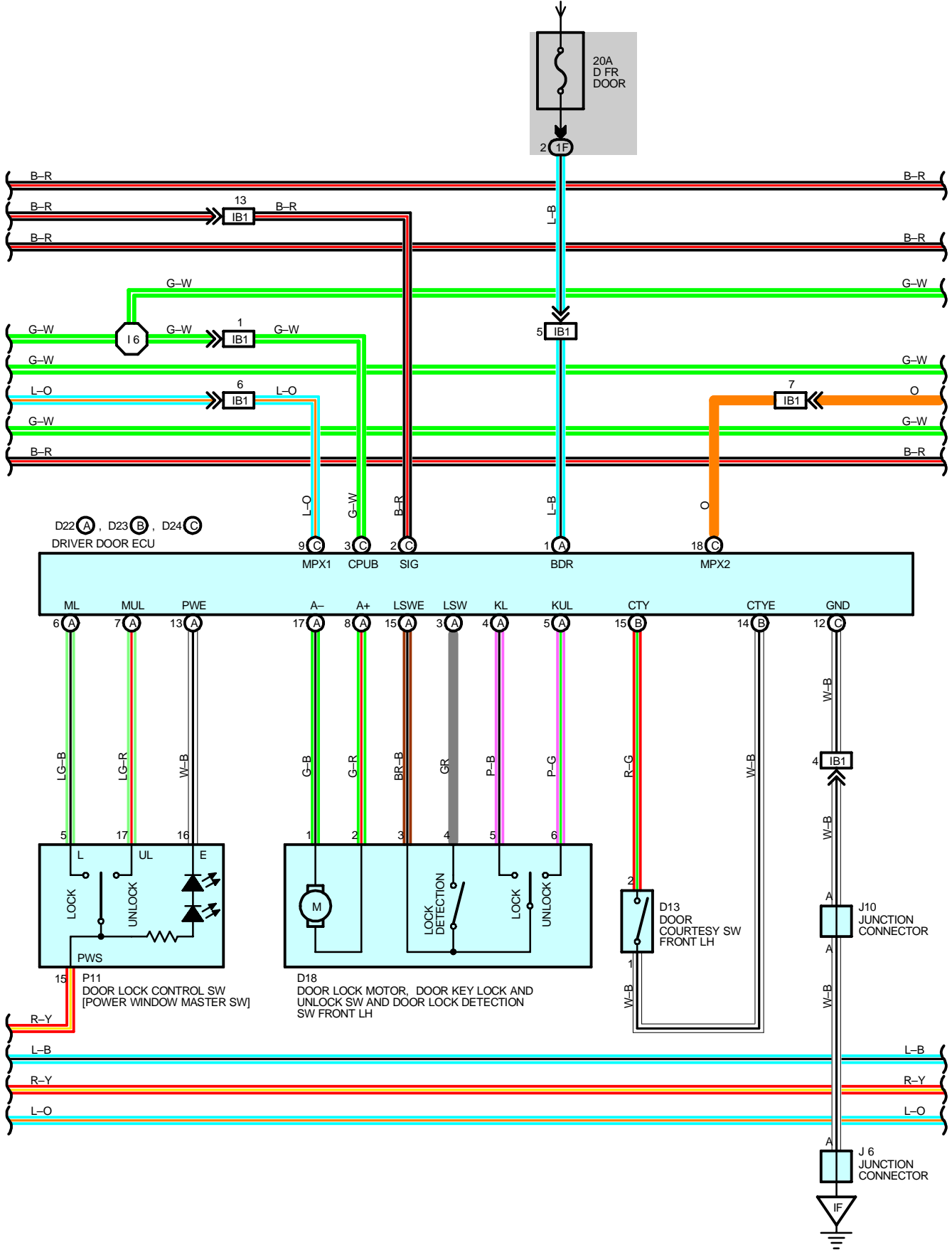

WIRELESS DOOR LOCK CONTROL

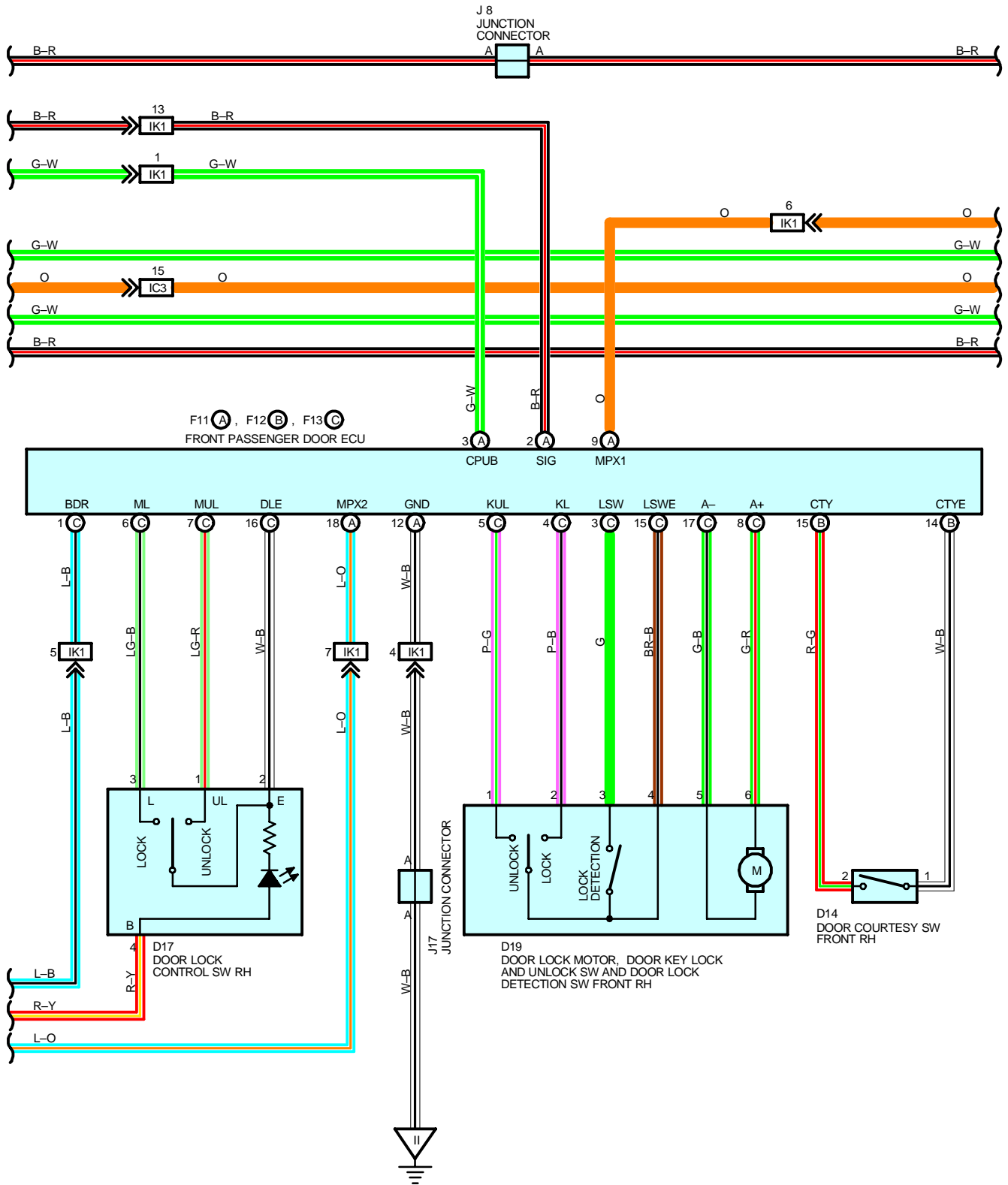

FROM POWER SOURCE SYSTEM (SEE PAGE 60)

* 5 : W/ DRIVING POSITION MEMORY
 * 6 : WO DRIVING POSITION MEMORY

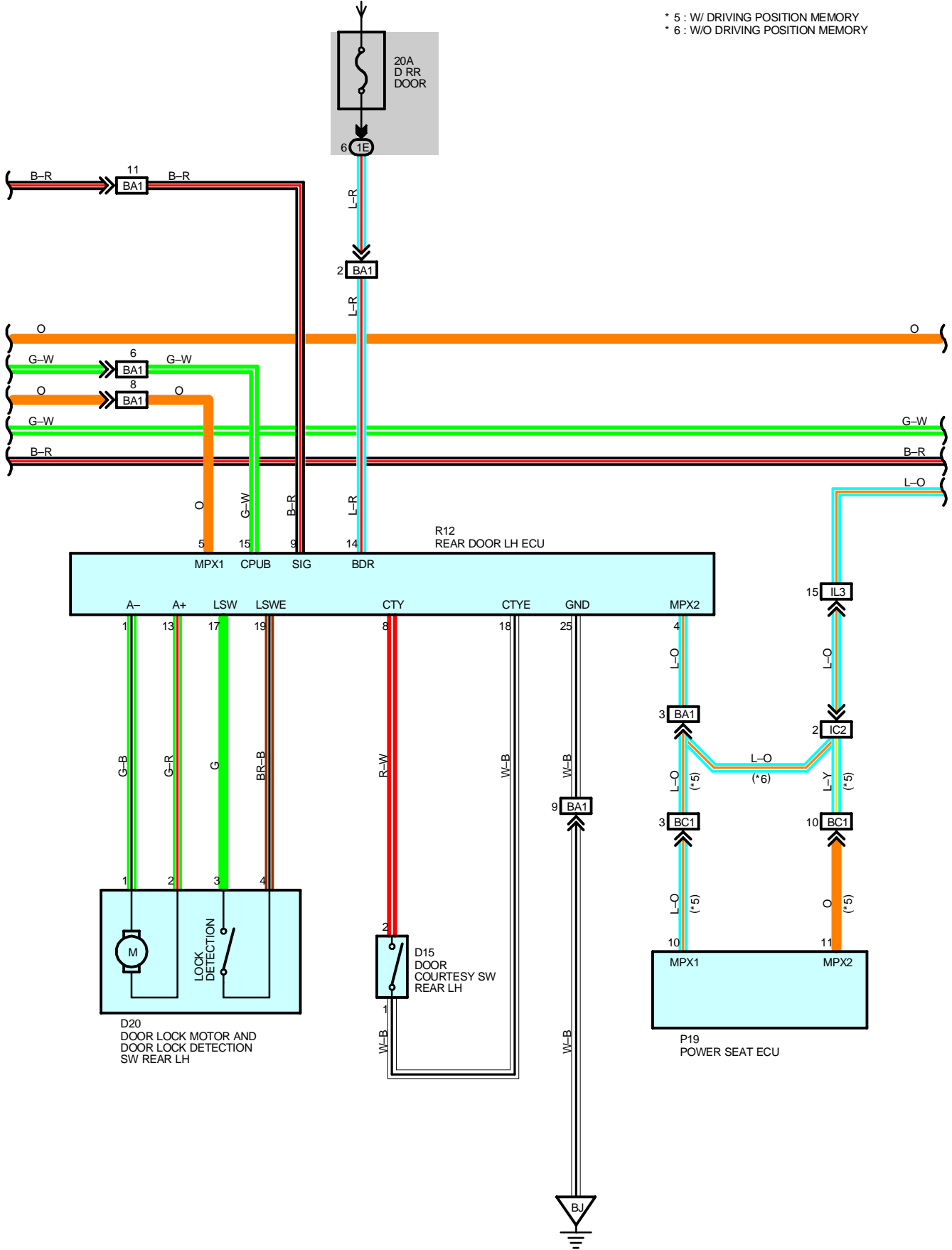

WIRELESS DOOR LOCK CONTROL

FROM POWER SOURCE SYSTEM (SEE PAGE 60)

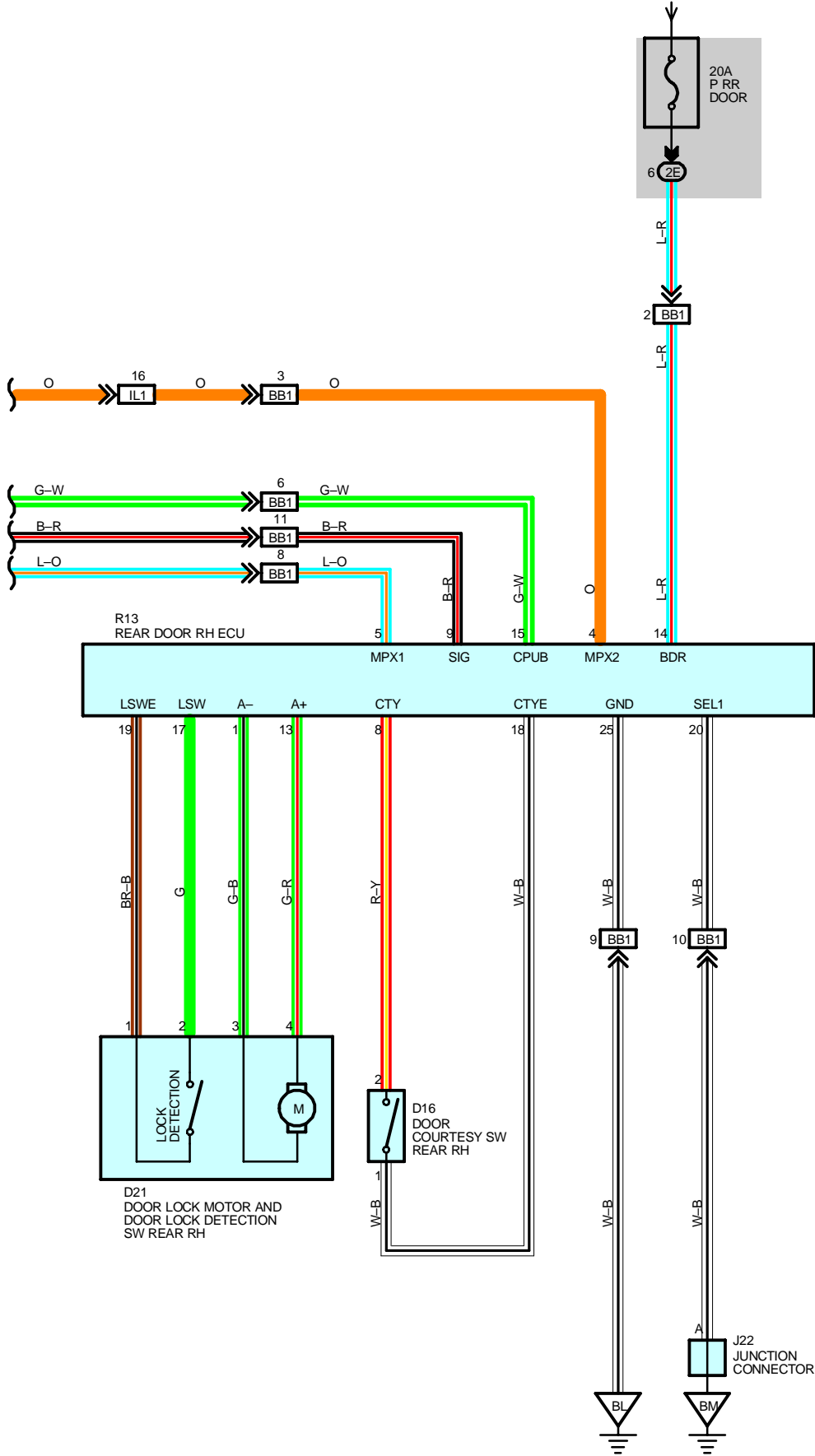

SYSTEM OUTLINE

In this system, the wireless door lock ECU receives weak radio wave transmitted from the transmitter built-into the ignition key and outputs the signal to the body ECU No.2. Through communication control of the body ECU and door ECU etc. , all the doors and the luggage door can be locked and unlocked by the remote control.

1. NORMAL OPERATION

Lock operation

When the lock SW on the transmitter is pressed, all the doors are locked.

Unlock operation

When the unlock SW on the transmitter is pressed once, only the driver door is unlocked. When the unlock SW is pressed again within 3 sec., all the doors are unlocked.

Luggage door unlock operation

When the luggage door unlock SW is kept pressed for approximately 1 sec. or longer, the luggage door is opened.

2. AUTO LOCK FUNCTION

If the door is not actually opened within 30 sec. after the door has been unlocked by pressing the unlock SW on the transmitter, all the doors are automatically locked. If any of the following conditions is detected, the auto lock does not function.

Any door is opened.

The ignition key is inserted into the ignition SW.

When the lock detection SW of all the doors are locked.

3. WIRELESS DOOR LOCK STOP FUNCTION

If any of the following conditions is detected, the wireless door lock does not function.

Lock operation

Any door is open (The door courtesy SW is on). The ignition key is inserted into the ignition key cylinder (The unlock warning SW is on). The ignition SW is turned to the ON position.

Unlock operation

The ignition SW is turned to the ON position.

Luggage door unlock operation

The ignition SW is turned to the ON position.

4. BUZZER SOUND FUNCTION

When the body ECU No.1 receives the door lock signal from the door ECU via the door lock motor, during lock operation, the wireless door lock buzzer goes on once (for approximately 0.1 sec.).

When the body ECU No.1 receives the door unlock signal from the door ECU via the door lock motor, during unlock operation, the wireless door lock buzzer goes on twice (for approximately 0.2 sec. at intervals of 0.1 sec.).

When the luggage door is unlocked, and the body ECU No.1 outputs the unlock signal, the wireless door lock buzzer goes on once (for approximately 0.5 sec.).

When the body ECU No.1 receives the lock signal from the transmitter while any door is open, the wireless door lock buzzer sounds for approximately 10 sec. If the door is closed or if the unlock signal is received from the transmitter while the buzzer is sounding, the buzzer stops.

5. CAR FINDER FUNCTION

When the lock SW on the transmitter is pressed with all the doors locked, the body ECU No.1 receives the signal and the hazard light flashes once through communication control of the body ECU and door ECU etc.

6. ILLUMINATED ENTRY FUNCTION

When the body ECU No.2 detects the unlock state after the unlock operation has been made, it turns on the lights, such as the ignition key cylinder light for 15 sec. If all the doors are locked during this operation, lighting is cancelled and the lights immediately fade out.

7. PANIC MODE FUNCTION

When the lock switch on the transmitter is kept pressed for approximately 2.5 sec., the body ECU No.1 receives the signal and enters the panic mode. The theft alarm goes on upon receiving the signal, the body ECU No.1, and the headlights and taillights flash through the communication of the body ECU and door ECU etc. At this time, when any SW on the transmitter is pressed, the panic mode is cancelled, the theft alarm is stopped, and the headlights and taillights go off.

8. REPEAT FUNCTION

If the lock detection signal in response to the output signal is not received after the body ECU No.1 has output the lock signal, the lock signal is output again after approximately 2 sec.

WIRELESS DOOR LOCK CONTROL

SERVICE HINTS

W5 WIRELESS DOOR LOCK ECU

- 1-GROUND : Always continuity
- 7-GROUND : Always approx. 12 volts

L5 LUGGAGE COMPARTMENT DOOR OPENER MOTOR

- 1-GROUND : Approx. 12 volts with luggage door open operate

D18 DOOR LOCK MOTOR, DOOR KEY LOCK AND UNLOCK SW AND DOOR LOCK DETECTION SW FRONT LH

- 2-GROUND : Approx. 12 volts with door lock motor at lock operate
- 1-GROUND : Approx. 12 volts with door lock motor at unlock operate
- 5-3 : Closed with door lock cylinder locked with key
- 6-3 : Closed with door lock cylinder unlocked with key

D19 DOOR LOCK MOTOR, DOOR KEY LOCK AND UNLOCK SW AND DOOR LOCK DETECTION SW FRONT RH

- 6-GROUND : Approx. 12 volts with door lock motor at lock operate
- 5-GROUND : Approx. 12 volts with door lock motor at unlock operate
- 2-4 : Closed with door lock cylinder locked with key
- 1-4 : Closed with door lock cylinder unlocked with key

D20 DOOR LOCK MOTOR AND DOOR LOCK DETECTION SW REAR LH

- 2-GROUND : Approx. 12 volts with door lock motor at lock operate
- 1-GROUND : Approx. 12 volts with door lock motor at unlock operate

D21 DOOR LOCK MOTOR AND DOOR LOCK DETECTION SW REAR RH

- 4-GROUND : Approx. 12 volts with door lock motor at lock operate
- 3-GROUND : Approx. 12 volts with door lock motor at unlock operate

○ : PARTS LOCATION

Code	See Page	Code	See Page	Code	See Page		
A13	40	D23	B	42	J17	41	
B5	A	40	D24	C	42	J22	42
B6	A	40	E5	D	38 (2JZ-GE)	L5	43
C13	40	E7	F	36 (1UZ-FE)	M3	41	
D13	42	F11	A	42	P11	43	
D14	42	F12	B	42	P19	44	
D15	42	F13	C	42	R12	43	
D16	42	H18	40	R13	43		
D17	42	J6	41	T5	41		
D18	42	J7	41	W4	37 (1UZ-FE)		
D19	42	J8	41		39 (2JZ-GE)		
D20	42	J10	41	W5	43		
D21	42	J13	41				
D22	A	42	J15	41			

○ : RELAY BLOCKS

Code	See Page	Relay Blocks (Relay Block Location)
1	22	Engine Room No.1 R/B (Engine Compartment Right)

 : JUNCTION BLOCK AND WIRE HARNESS CONNECTOR

Code	See Page	Junction Block and Wire Harness (Connector Location)
1E	26	Floor No.2 Wire and Driver Side J/B (Left Kick Panel)
1F	26	Cowl Wire and Driver Side J/B (Left Kick Panel)
1G	27	
1H		
2B	28	
2E	28	Floor No.1 Wire and Passenger Side J/B (Right Kick Panel)
2F	28	Cowl Wire and Passenger Side J/B (Right Kick Panel)
2G	29	
2H		

 : CONNECTOR JOINING WIRE HARNESS AND WIRE HARNESS

Code	See Page	Joining Wire Harness and Wire Harness (Connector Location)
IB1	50	Front Door LH Wire and Cowl Wire (Left Kick Panel)
IC1	50	Floor No.2 Wire and Cowl Wire (Left Kick Panel)
IC2		
IC3		
IE1	50	Instrument Panel Wire and Cowl Wire (Left Side of the Steering Column)
IJ1	52	Instrument Panel Wire and Cowl Wire (Left Side of the Blower Unit)
IJ2		
IK1	52	Front Door RH Wire and Cowl Wire (Right Kick Panel)
IL1	52	Floor No.1 Wire and Cowl Wire (Right Kick Panel)
IL3		
BA1	54	Rear Door LH Wire and Floor No.2 Wire (Under the Center Pillar LH)
BB1	54	Rear Door RH Wire and Floor No.1 Wire (Under the Center Pillar RH)
BC1	56	Floor No.2 Wire and Front Seat LH Wire (Under the Driver's Seat)

 : GROUND POINTS

Code	See Page	Ground Points Location
IF	50	Left Kick Panel
II	50	Right Side of the Cowl Panel
BJ	54	Rear Floor Partition Panel LH
BL	54	Rear Floor Partition Panel RH
BM	54	Quarter Panel RH

 : SPLICE POINTS

Code	See Page	Wire Harness with Splice Points	Code	See Page	Wire Harness with Splice Points
I6	52	Cowl Wire			

WIRELESS DOOR LOCK CONTROL

A13

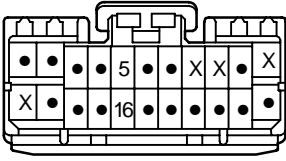

B5 (A)

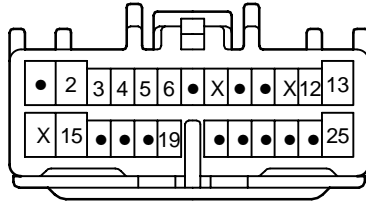

B6 (A)

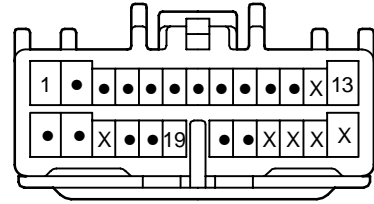

C13

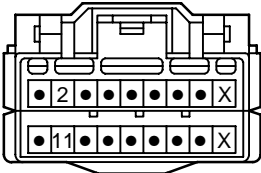

**D13
GRAY**

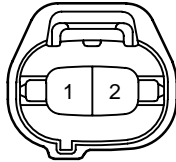

**D14
GRAY**

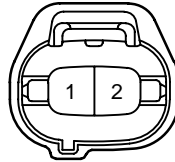

**D15
GRAY**

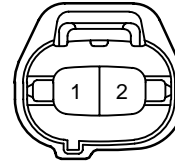

**D16
GRAY**

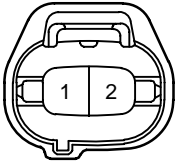

D17

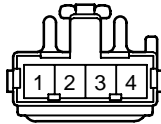

**D18
BLACK**

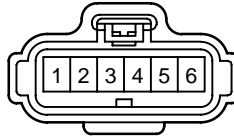

**D19
BLACK**

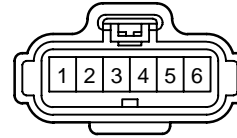

**D20
BLACK**



**D21
BLACK**

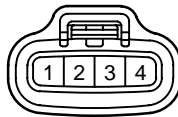

**D22 (A)
GRAY**

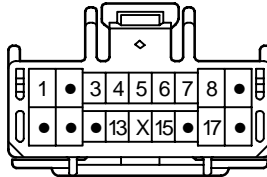

**D23 (B)
GRAY**

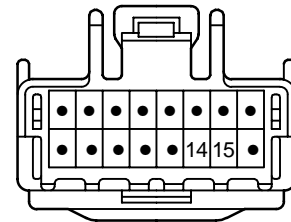

**D24 (C)
GRAY**

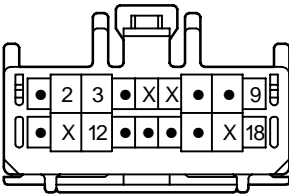

**E5 (D)
(2JZ-GE)**

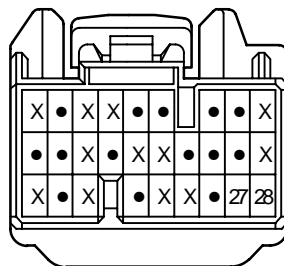

**E7 (F)
(1UZ-FE)**

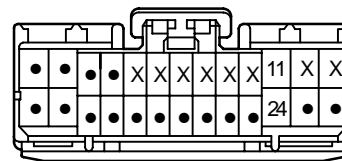

F11 (A)
GRAY

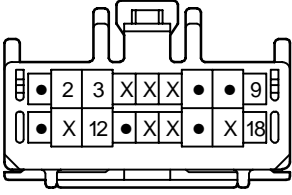

F12 (B)
GRAY

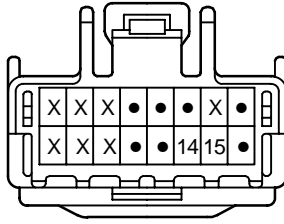

F13 (C)
GRAY

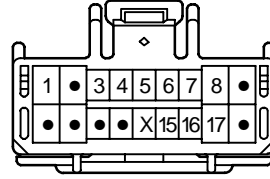

H18
BLACK

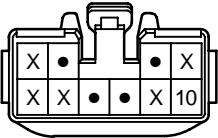

J6

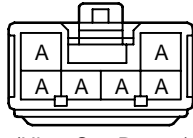

(Hint : See Page 7)

J7
GRAY

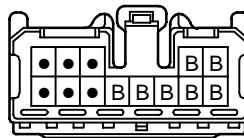

(Hint : See Page 7)

J8
BLACK



(Hint : See Page 7)

J10
ORANGE

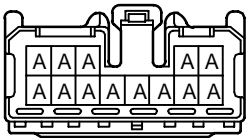

(Hint : See Page 7)

J13

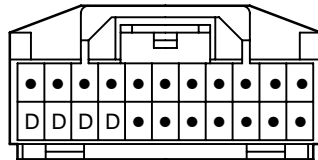

(Hint : See Page 7)

J15

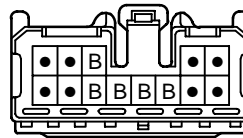

(Hint : See Page 7)

J17

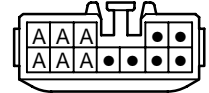

(Hint : See Page 7)

J22

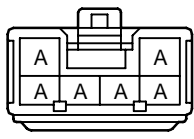

(Hint : See Page 7)

L5
BLACK

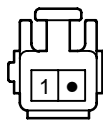

M3
BLUE

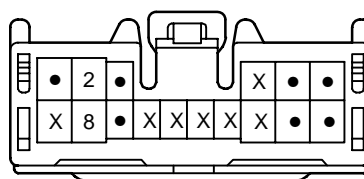

P11

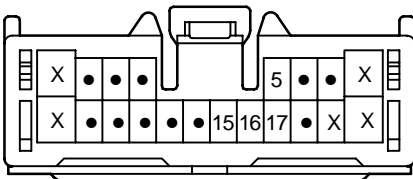

P19

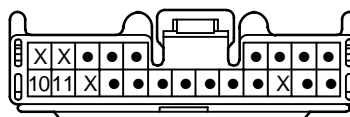

R12

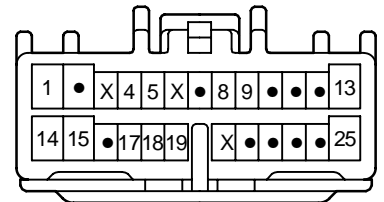

R13

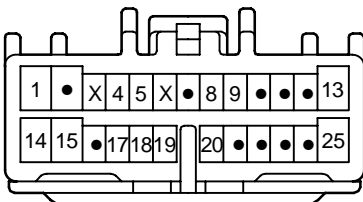

T5
GRAY

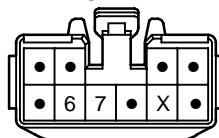

W4
BLACK

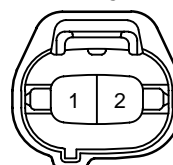

W5

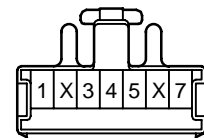

I GROUND POINT

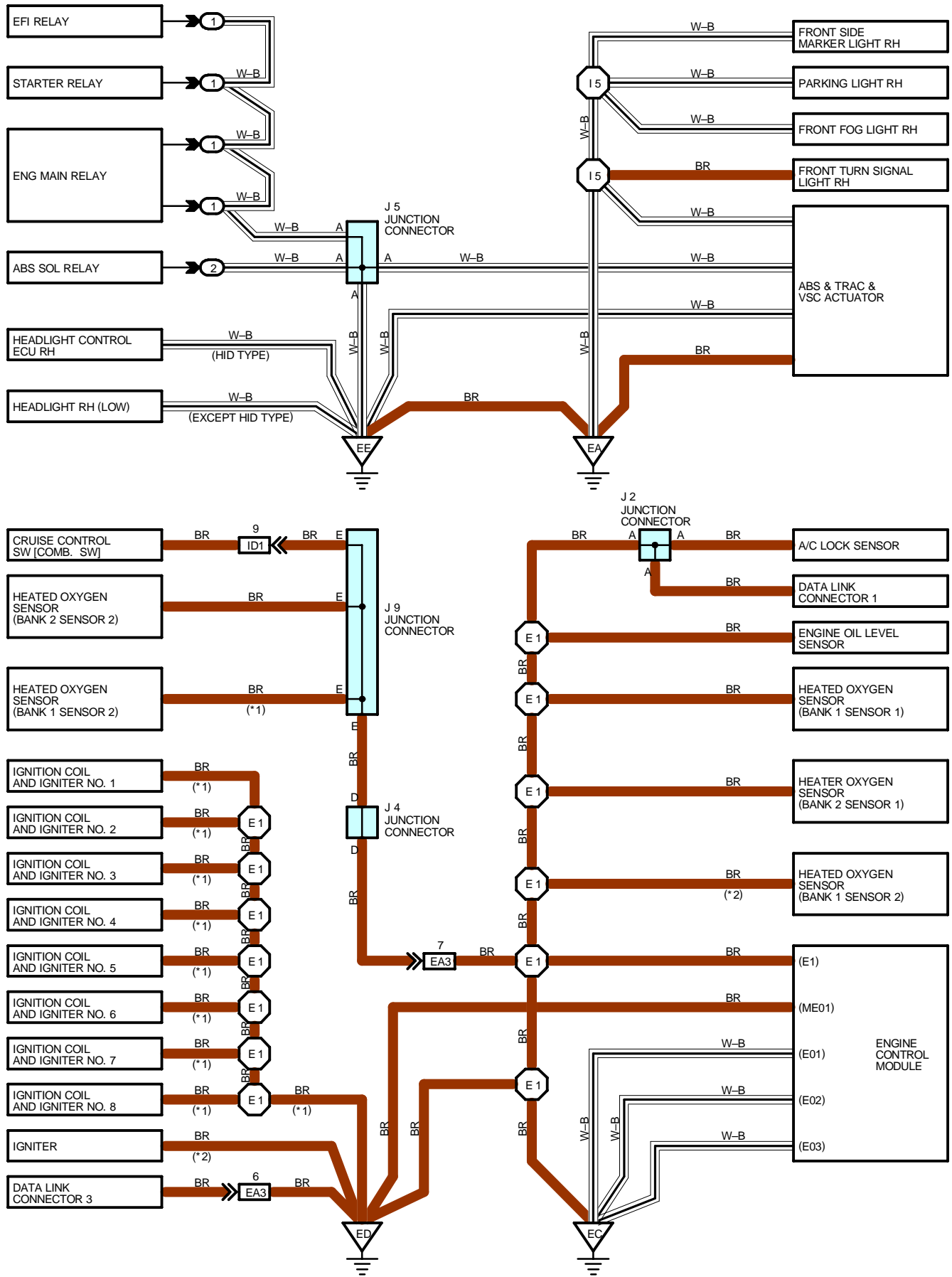

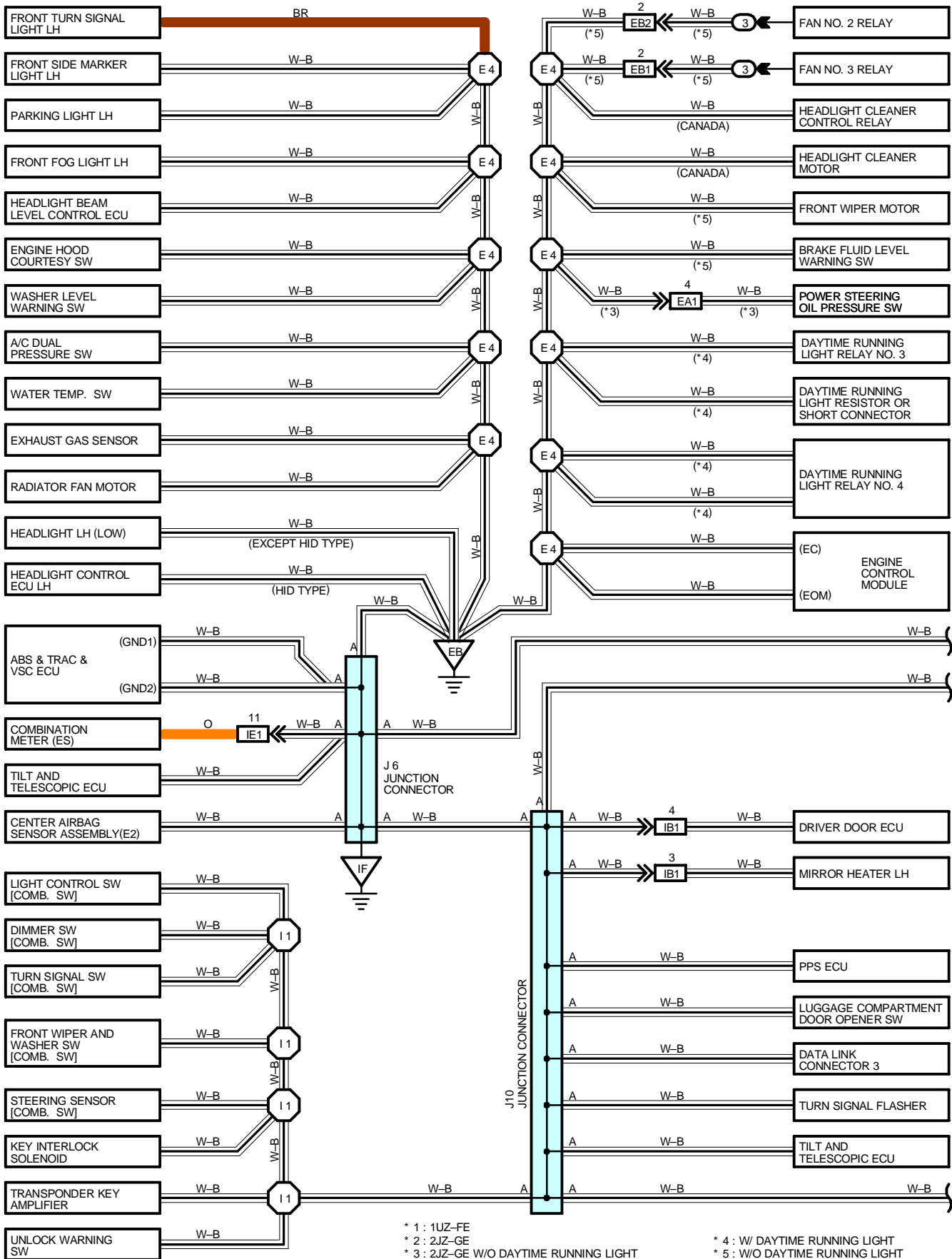

I GROUND POINT

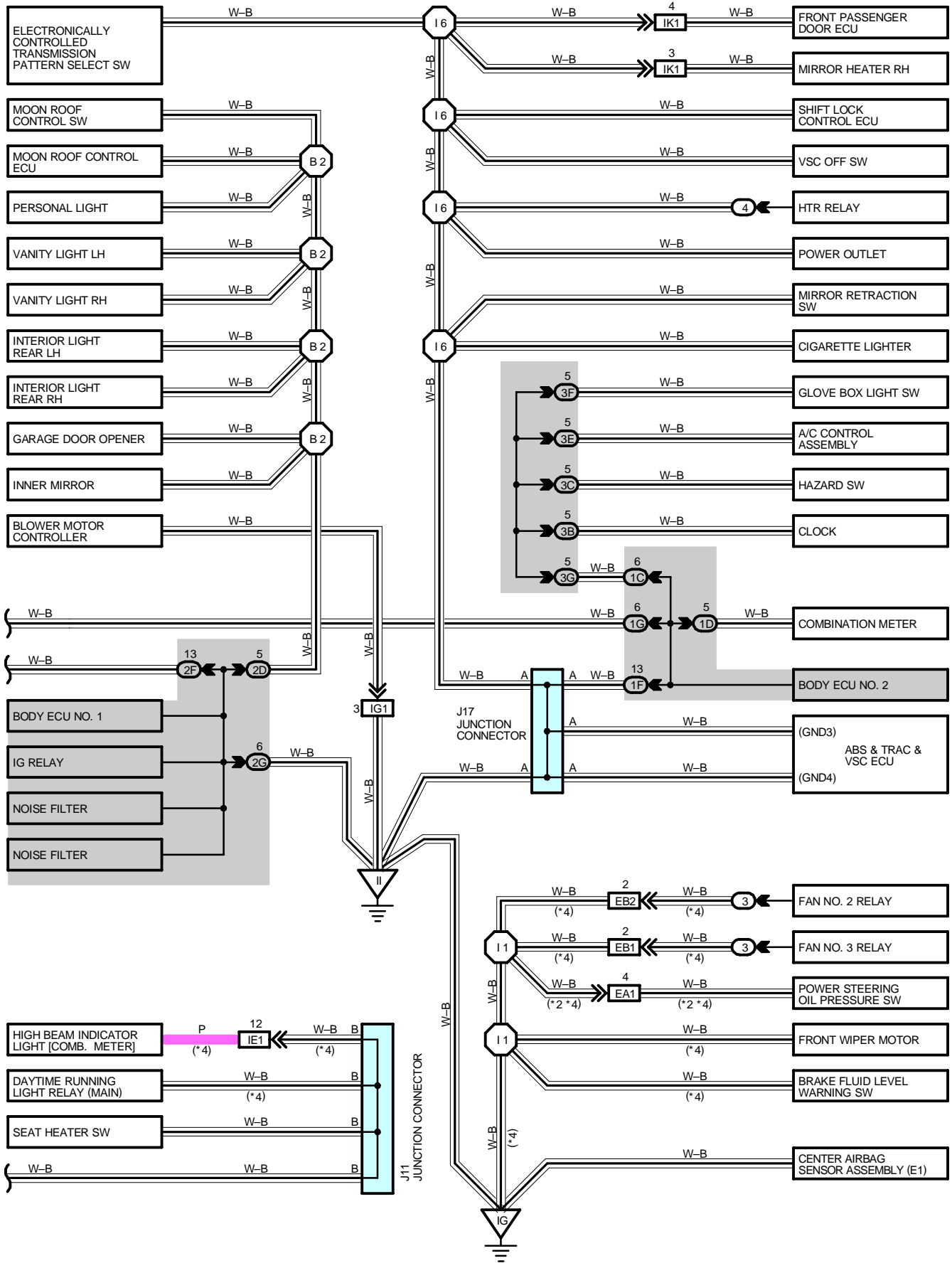

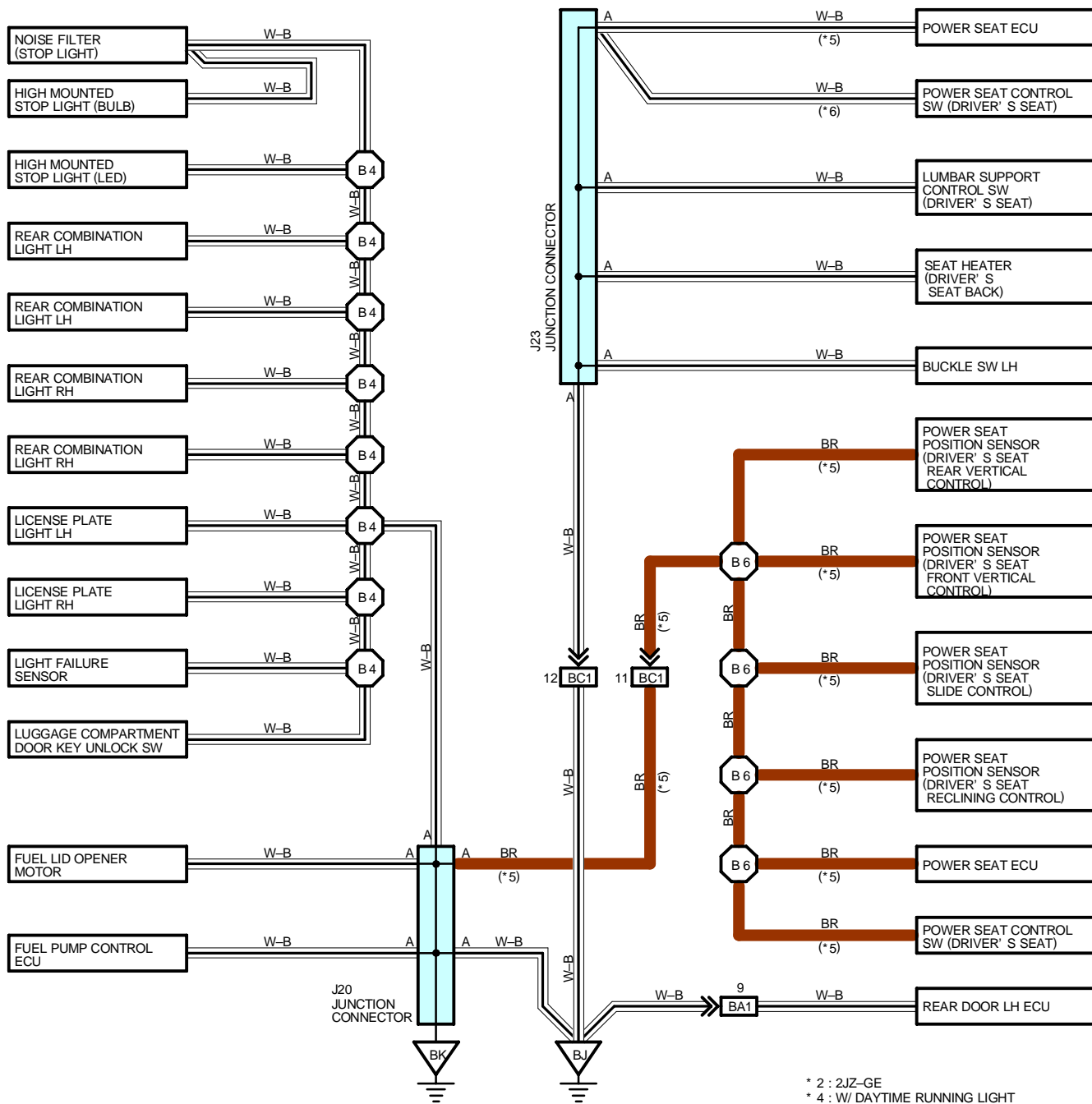

- * 2 : 2JZ-GE
- * 4 : W/ DAYTIME RUNNING LIGHT
- * 5 : W/ DRIVING POSITION MEMORY
- * 6 : W/O DRIVING POSITION MEMORY

I GROUND POINT

* 7 : W/ LEXUS NAVIGATION SYSTEM

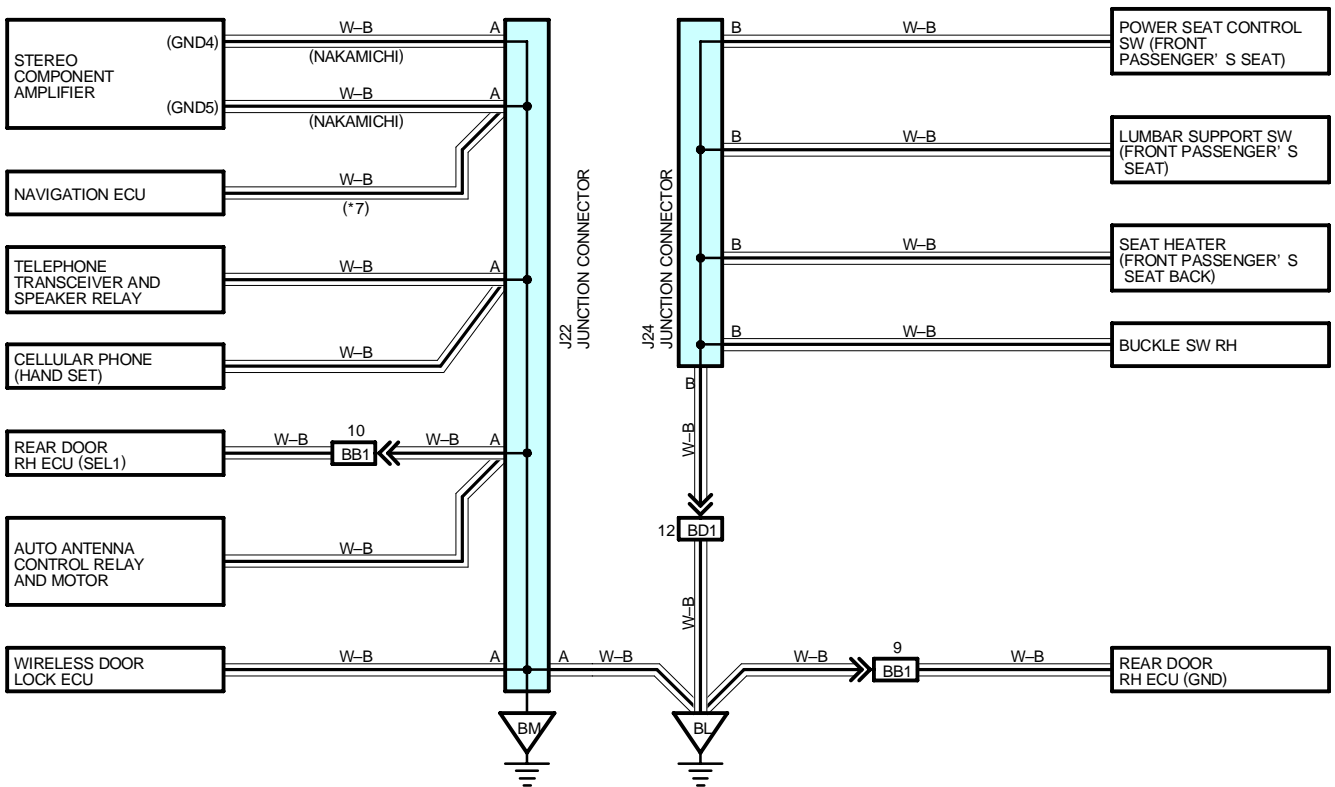
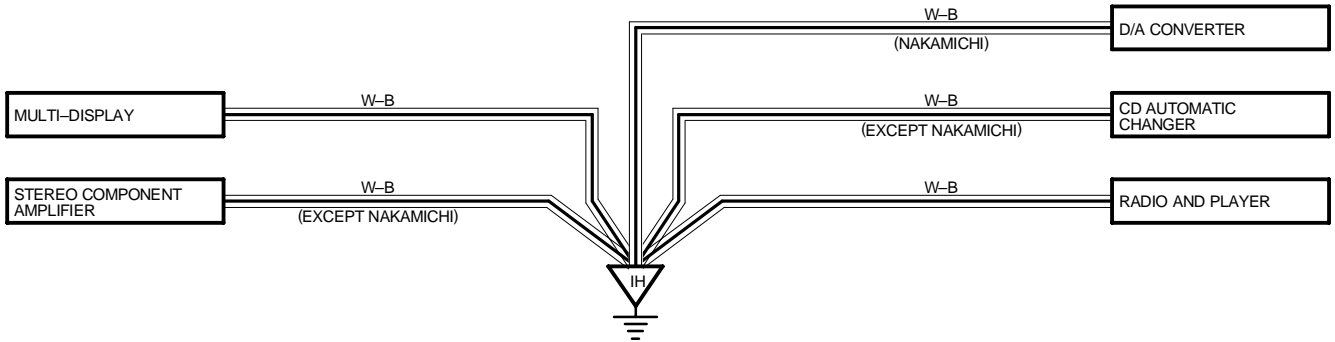

○ : PARTS LOCATION

Code	See Page	Code	See Page	Code	See Page
J2	37 (1UZ-FE)	J5	39 (2JZ-GE)	J17	41
	39 (2JZ-GE)	J6	41	J20	42
J4	37 (1UZ-FE)	J9	41	J22	42
	39 (2JZ-GE)	J10	41	J23	44
J5	37 (1UZ-FE)	J11	41	J24	44

○ : RELAY BLOCKS

Code	See Page	Relay Blocks (Relay Block Location)
1	22	Engine Room No.1 R/B (Engine Compartment Right)
2	23	Engine Room No.2 R/B (Engine Compartment Left)
3	24	Engine Room No.3 R/B (Engine Compartment Left)
4	25	Passenger Side R/B (Right Kick Panel)

○ : JUNCTION BLOCK AND WIRE HARNESS CONNECTOR

Code	See Page	Junction Block and Wire Harness (Connector Location)
1C	26	Instrument Panel Wire and Driver Side J/B (Left Kick Panel)
1D		
1F	26	Cowl Wire and Driver Side J/B (Left Kick Panel)
1G	27	
2D	28	Roof Wire and Passenger Side J/B (Right Kick Panel)
2F	28	Cowl Wire and Passenger Side J/B (Right Kick Panel)
2G	29	
3B	30	Instrument Panel Wire and Instrument Panel J/B (Instrument Panel Reinforcement Center)
3C		
3E	31	Instrument Panel Wire and Instrument Panel J/B (Instrument Panel Reinforcement Center)
3F		
3G		

□ : CONNECTOR JOINING WIRE HARNESS AND WIRE HARNESS

Code	See Page	Joining Wire Harness and Wire Harness (Connector Location)
EA1	48 (2JZ-GE)	Engine Wire and Cowl Wire (Inside of the ECU Box)
EA3	46 (1UZ-FE)	
	48 (2JZ-GE)	
EB1	46 (1UZ-FE)	Cowl Wire and Relay Block Wire (Inside of the Engine Room No.3 R/B)
	48 (2JZ-GE)	
EB2	46 (1UZ-FE)	
	48 (2JZ-GE)	
IB1	50	Front Door LH Wire and Cowl Wire (Left Kick Panel)
ID1	50	Cowl Wire and Cowl Wire (Left Side of the Instrument Panel Reinforcement)
IE1	50	Instrument Panel Wire and Cowl Wire (Left Side of the Steering Column)
IG1	50	Cowl Wire and Blower Sub Wire (Left Side of the Blower Unit)
IK1	52	Front Door RH Wire and Cowl Wire (Right Kick Panel)
BA1	54	Rear Door LH Wire and Floor No.2 Wire (Under the Center Pillar LH)
BB1	54	Rear Door RH Wire and Floor No.1 Wire (Under the Center Pillar RH)
BC1	56	Floor No.2 Wire and Front Seat LH Wire (Under the Driver's Seat)
BD1	56	Floor No.1 Wire and Front Seat RH Wire (Under the Front Passenger's Seat)

I GROUND POINT



: GROUND POINTS

Code	See Page	Ground Points Location
EA	46 (1UZ-FE)	Right Fender
	48 (2JZ-GE)	
EB	46 (1UZ-FE)	Left Fender
	48 (2JZ-GE)	
EC	46 (1UZ-FE)	RH Bank of the Cylinder Head
	48 (2JZ-GE)	Front Side of the Intake Manifold
ED	46 (1UZ-FE)	LH Bank of the Cylinder Head
	48 (2JZ-GE)	Rear Side of the Intake Manifold
EE	46 (1UZ-FE)	Under the ABS & TRAC & VSC Actuator
	48 (2JZ-GE)	
IF	50	Left Kick Panel
IG	50	Left Side of the Cowl Panel
IH	50	Instrument Panel Brace RH
II	50	Right Side of the Cowl Panel
BJ	54	Rear Floor Partition Panel LH
BK	54	Quarter Panel LH
BL	54	Rear Floor Partition Panel RH
BM	54	Quarter Panel RH



: SPLICE POINTS

Code	See Page	Wire Harness with Splice Points	Code	See Page	Wire Harness with Splice Points
E1	46 (1UZ-FE)	Engine Wire	I5	52	Engine Room Main Wire
	48 (2JZ-GE)		I6	52	Cowl Wire
E4	46 (1UZ-FE)	Cowl Wire	B2	54	Roof Wire
	48 (2JZ-GE)		B4	54	Floor No.2 Wire
I1	52		B6	56	Front Seat LH Wire

J2
ORANGE

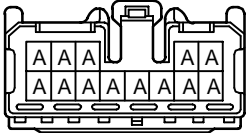

(Hint : See Page 7)

J4

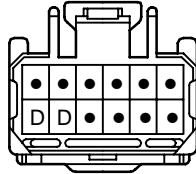

(Hint : See Page 7)

J5
BLUE



(Hint : See Page 7)

J6

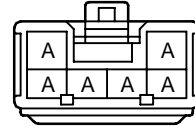

(Hint : See Page 7)

J9
(1UZ-FE)

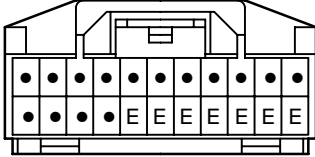

(Hint : See Page 7)

J9
(2JZ-GE)

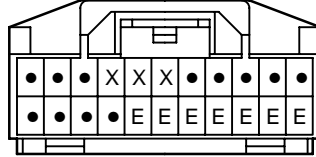

(Hint : See Page 7)

J10
ORANGE

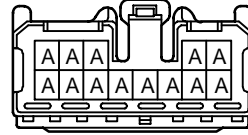

(Hint : See Page 7)

J11
GRAY

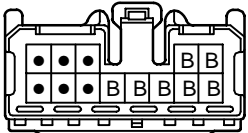

(Hint : See Page 7)

J17

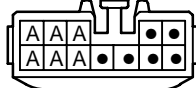

(Hint : See Page 7)

J20

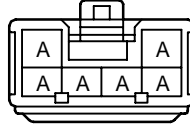

(Hint : See Page 7)

J22

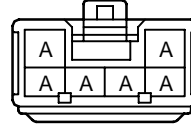

(Hint : See Page 7)

J23

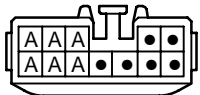

(Hint : See Page 7)

J24

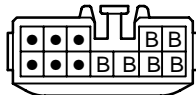

(Hint : See Page 7)

HOW TO READ THIS SECTION

* The system shown here is an EXAMPLE ONLY. It is different to the actual circuit shown in the wiring diagram section.

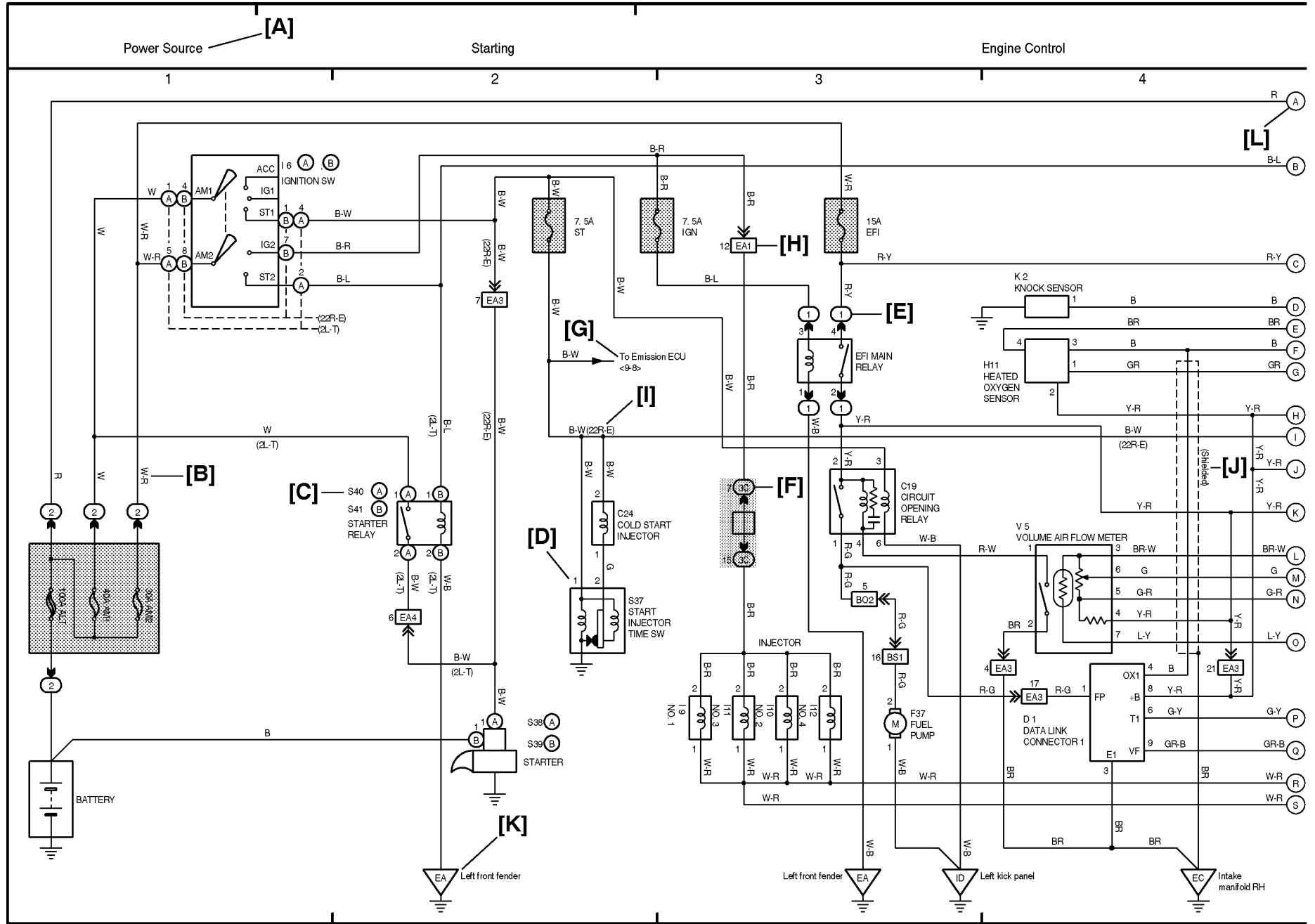

[A] : System Title

[B] : Indicates the wiring color.

Wire colors are indicated by an alphabetical code.

B = Black W = White BR = Brown
L = Blue V = Violet SB = Sky Blue
R = Red O = Orange LG = Light Green
P = Pink Y = Yellow GR = Gray
G = Green

The first letter indicates the basic wire color and the second letter indicates the color of the stripe.

Example: L - Y

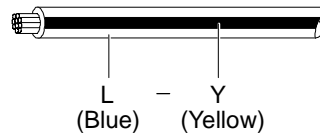

[C] : The position of the parts is the same as shown in the wiring diagram and wire routing.

[D] : Indicates the pin number of the connector. The numbering system is different for female and male connectors.

Example : Numbered in order from upper left to lower right

Numbered in order from upper right to lower left

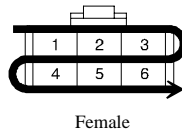

Female

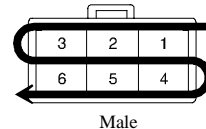

Male

The numbering system for the overall wiring diagram is the same as above

[E] : Indicates a Relay Block. No shading is used and only the Relay Block No. is shown to distinguish it from the J/B.

Example : ① Indicates Relay Block No.1

[F] : Junction Block (The number in the circle is the J/B No. and the connector code is shown beside it). Junction Blocks are shaded to clearly separate them from other parts.

Example:

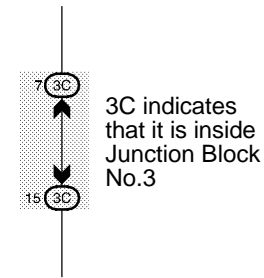

[G] : Indicates related system.

[H] : Indicates the wiring harness and wiring harness connector. The wiring harness with male terminal is shown with arrows (↘). Outside numerals are pin numbers.

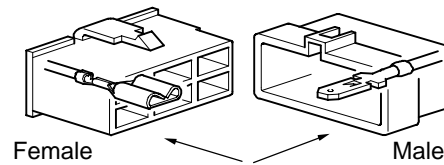

Female

Male (↘)

[I] : () is used to indicate different wiring and connector, etc. when the vehicle model, engine type, or specification is different.

[J] : Indicates a shielded cable.



[K] : Indicates and located on ground point.

[L] : The same code occurring on the next page indicates that the wire harness is continuous.

SYSTEM INDEX

SYSTEMS	LOCATION	SYSTEMS	LOCATION
Auto Antenna	18-2	LEXUS Navigation System	25-3
Automatic Air Conditioning	29-2	Moon Roof	20-2
Automatic Glare-Resistant EC Mirror	21-2	Multiplex Communication System	1-2
Back-Up Light	10-2	Power Seat	
Cellular Mobile Telephone	23-2	Driver's Seat w/o Driving Position Memory	22-2
Charging	3-4	Front Passenger's Seat	22-3
Cigarette Lighter and Power Outlet	18-3	Power Source	1~30-1
Clock	18-4	Power Tilt and Power Telescopic	20-4
Combination Meter	28-2	PPS	24-1
Cruise Control		Radiator Fan and Condenser Fan	30-2
1UZ-FE	14-2	Radio and Player	
2JZ-GE	15-2	NAKAMICHI	26-2
Electric Tension Reducer	18-2	Except NAKAMICHI	27-2
Electronically Controlled Transmission and A/T Indicator		Rear Window Defogger and Mirror Heater	24-3
1UZ-FE	12-2	Seat Heater	21-4
2JZ-GE	13-2	Shift Lock	25-1
Engine Control and Engine Immobiliser System		SRS	17-2
1UZ-FE	4-2	Starting and Ignition	
2JZ-GE	5-2	1UZ-FE	2-2
Fog Light	6-4	2JZ-GE	3-2
Fuel Lid Opener	18-4	Taillight and Stop Light	8-2
Headlight		Turn Signal and Hazard Warning Light	10-3
w/ Daytime Running Light	7-2	VSC	16-2
w/o Daytime Running Light	6-2	Wiper and Washer	19-2
Headlight Beam Level Control	11-2		
Headlight Cleaner	11-4		
Horn	19-4		
Illumination	9-2		

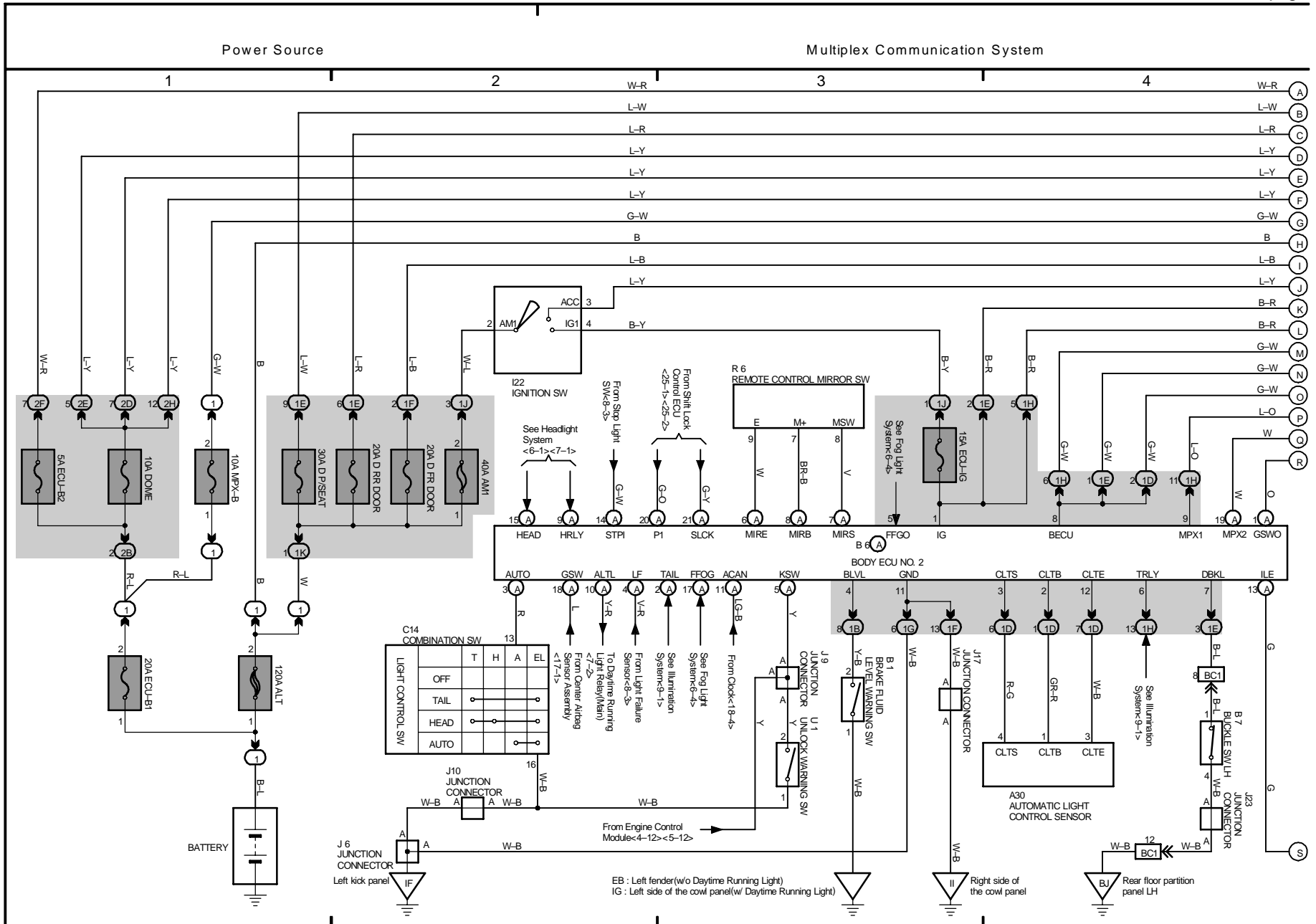

Multiplex Communication System

* 1 : w/ LEXUS Navigation System
 * 2 : w/o LEXUS Navigation System

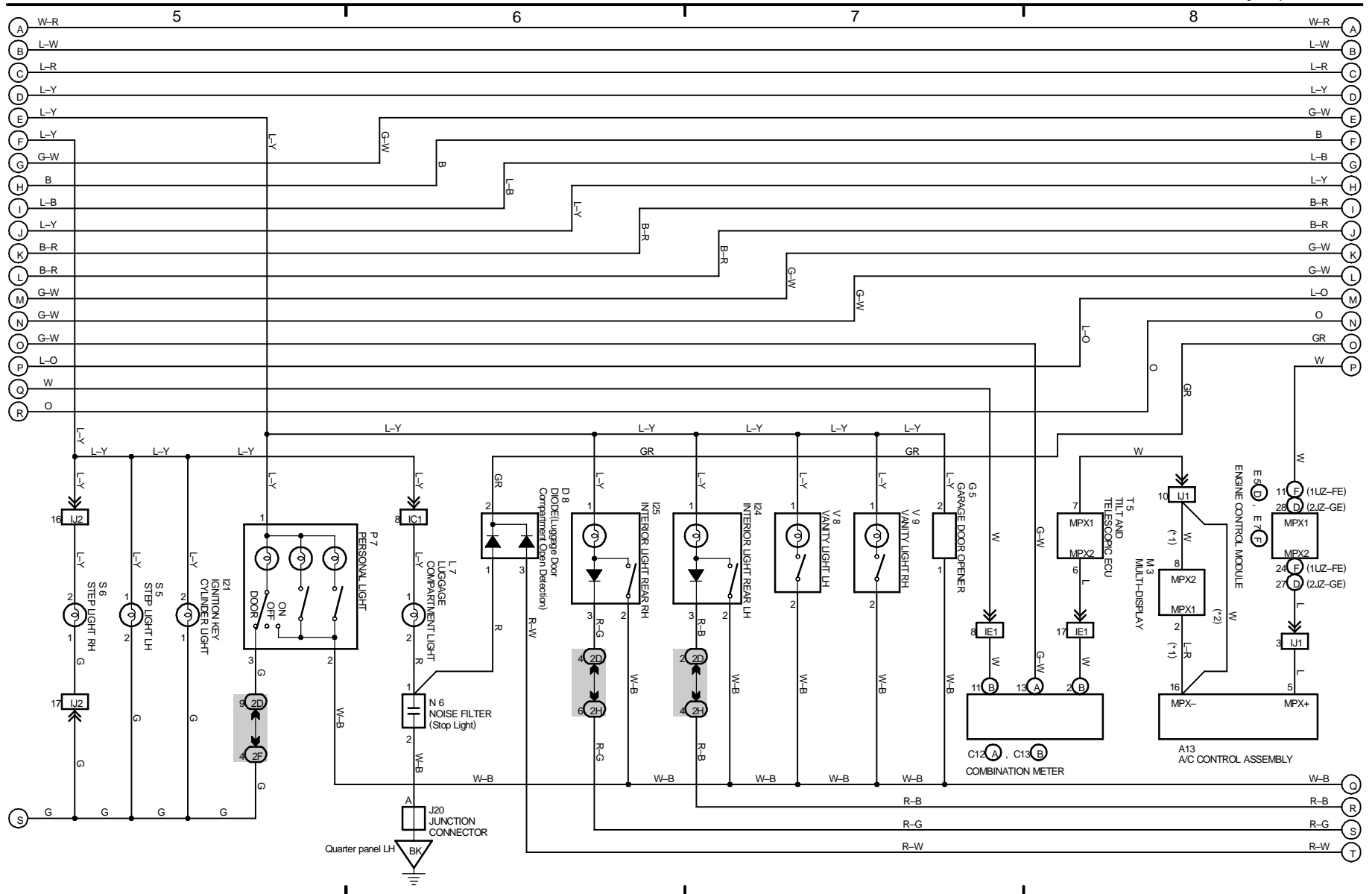

Multiplex Communication System

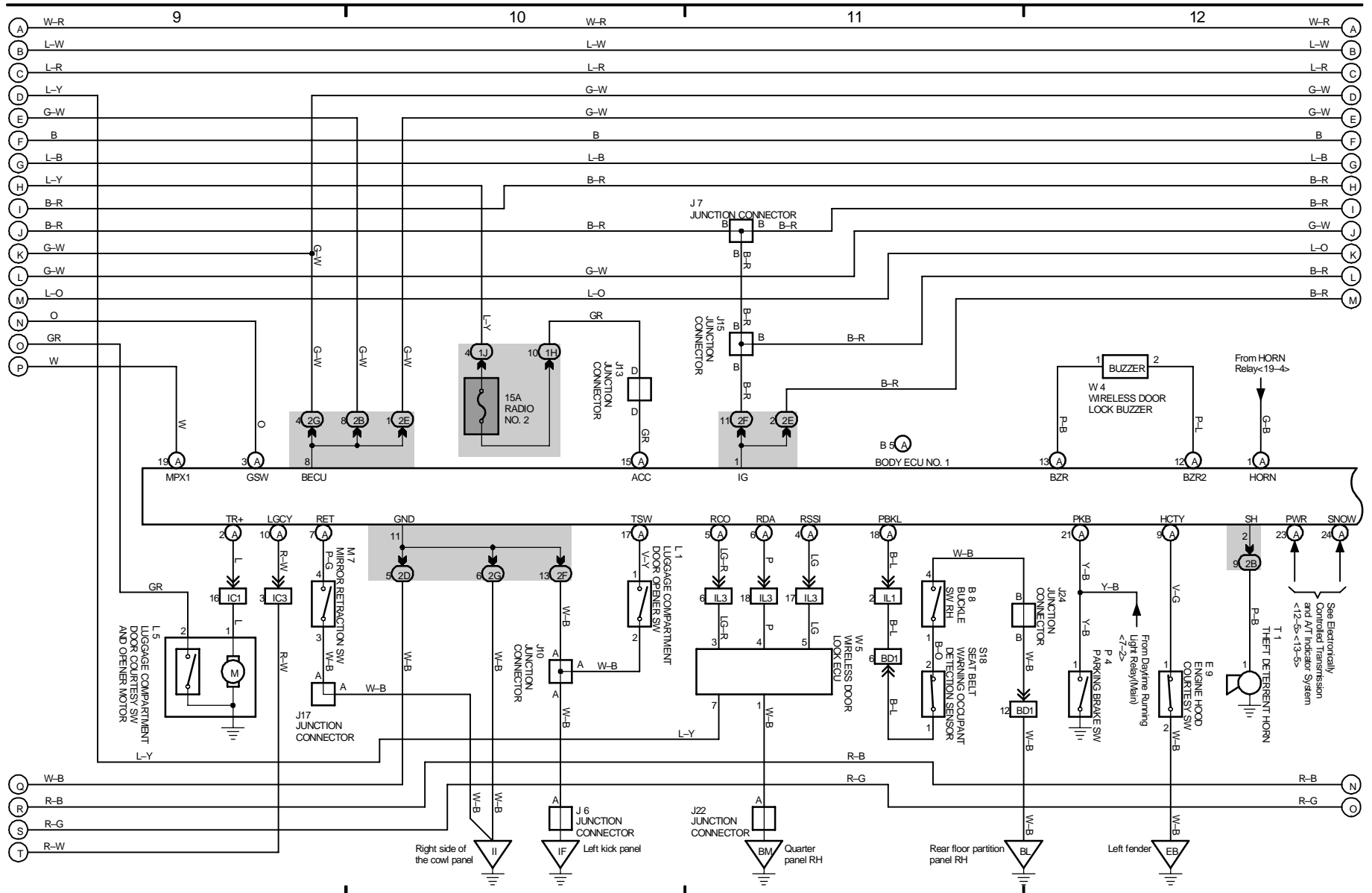

Multiplex Communication System

* 3 : w/ Driving Position Memory

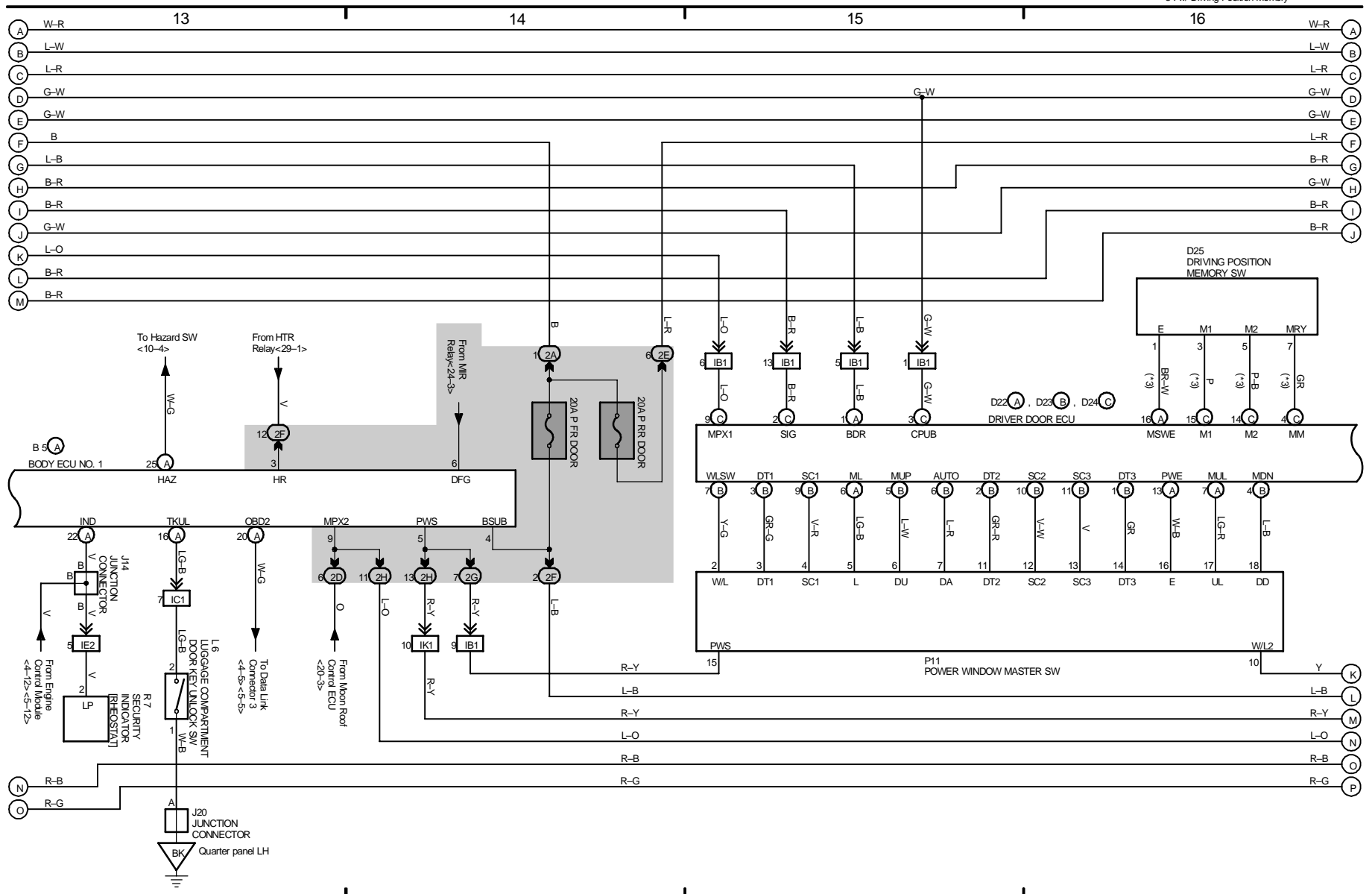

Multiplex Communication System

- * 3 : w/ Driving Position Memory
- * 4 : w/o Driving Position Memory
- * 5 : w/ Retraction

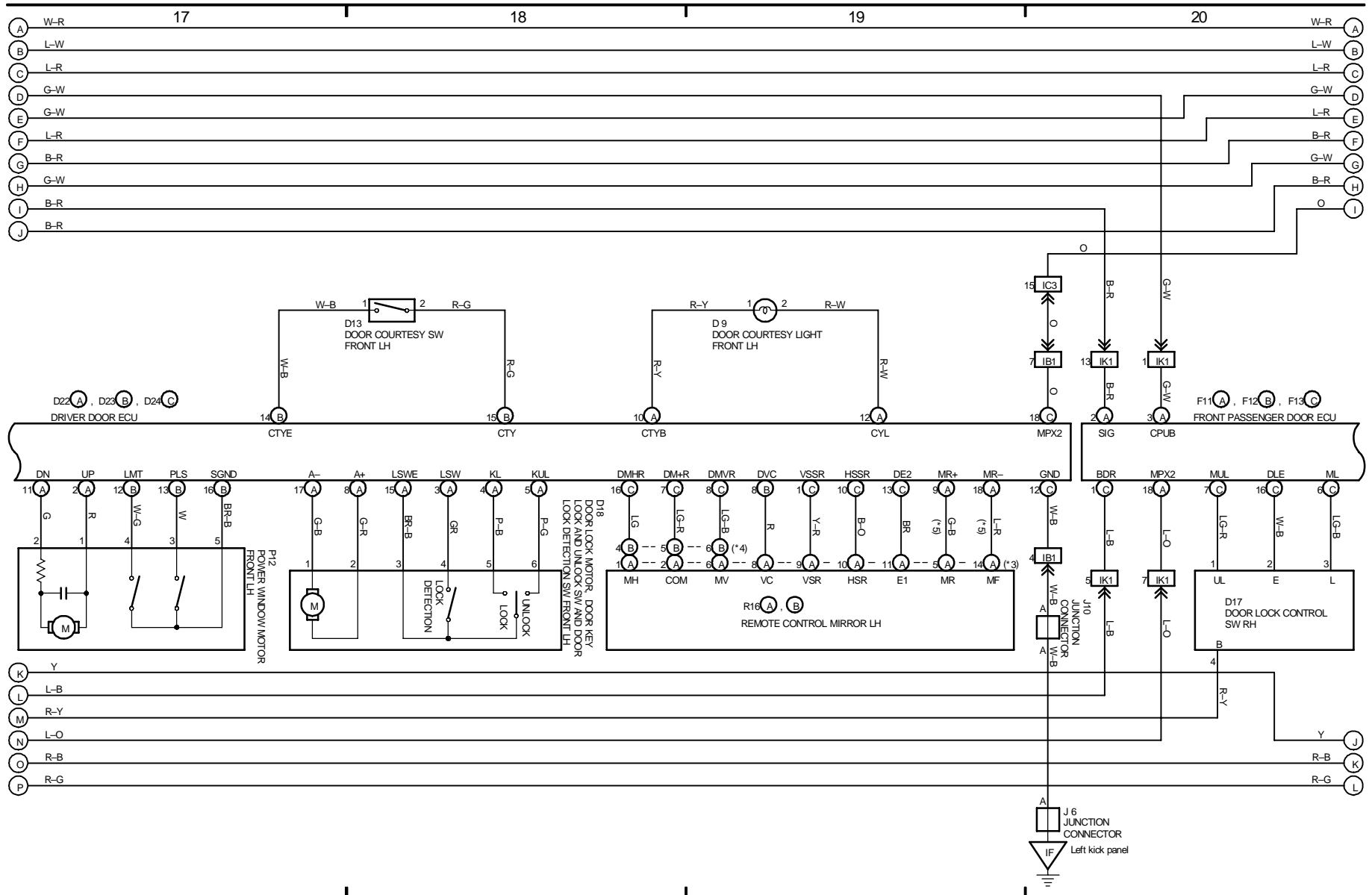

Multiplex Communication System

- * 3 : w/ Driving Position Memory
- * 4 : w/o Driving Position Memory
- * 5 : w/ Retraction

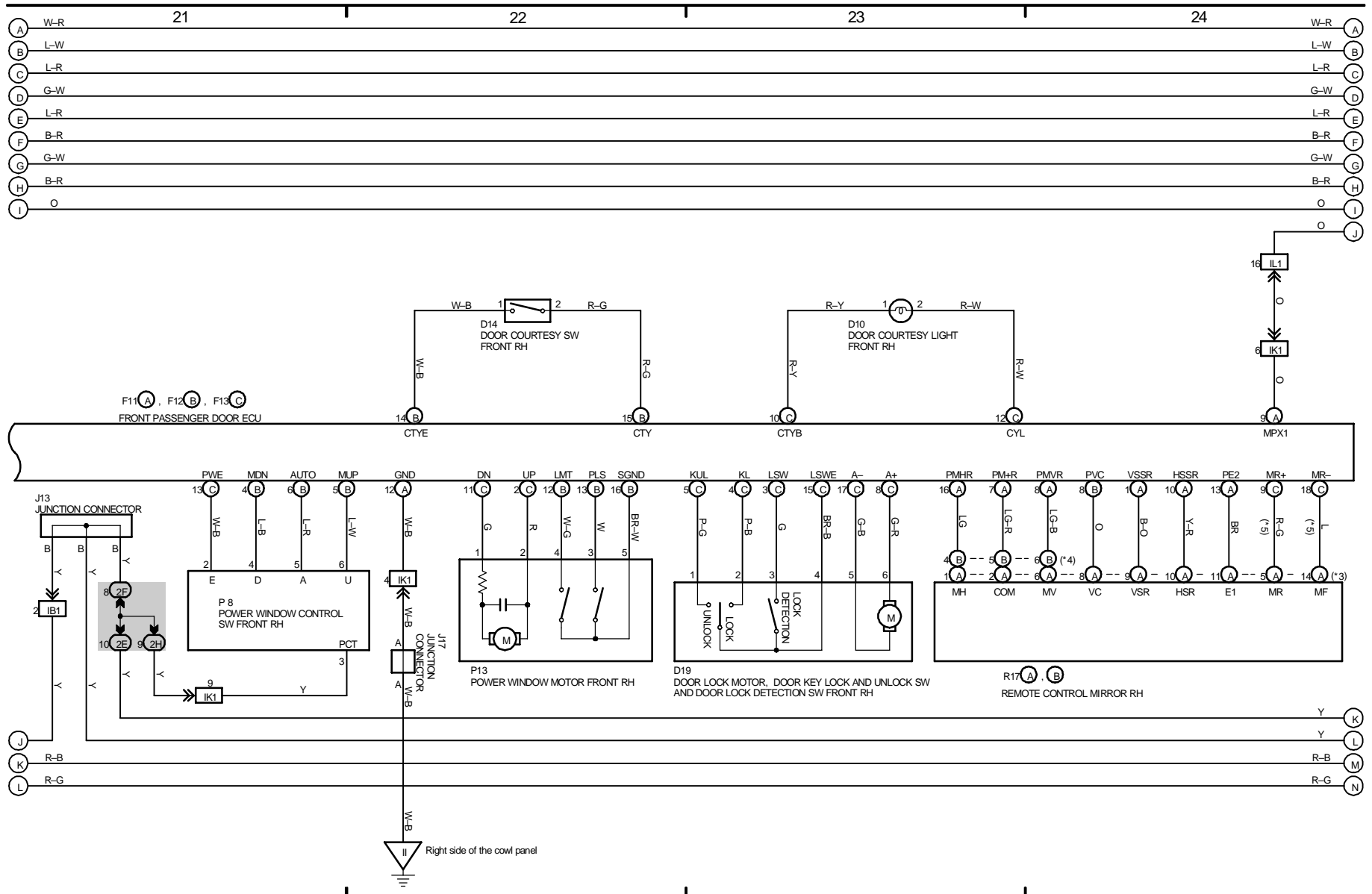

Multiplex Communication System

* 3 : w/ Driving Position Memory
 * 4 : w/o Driving Position Memory

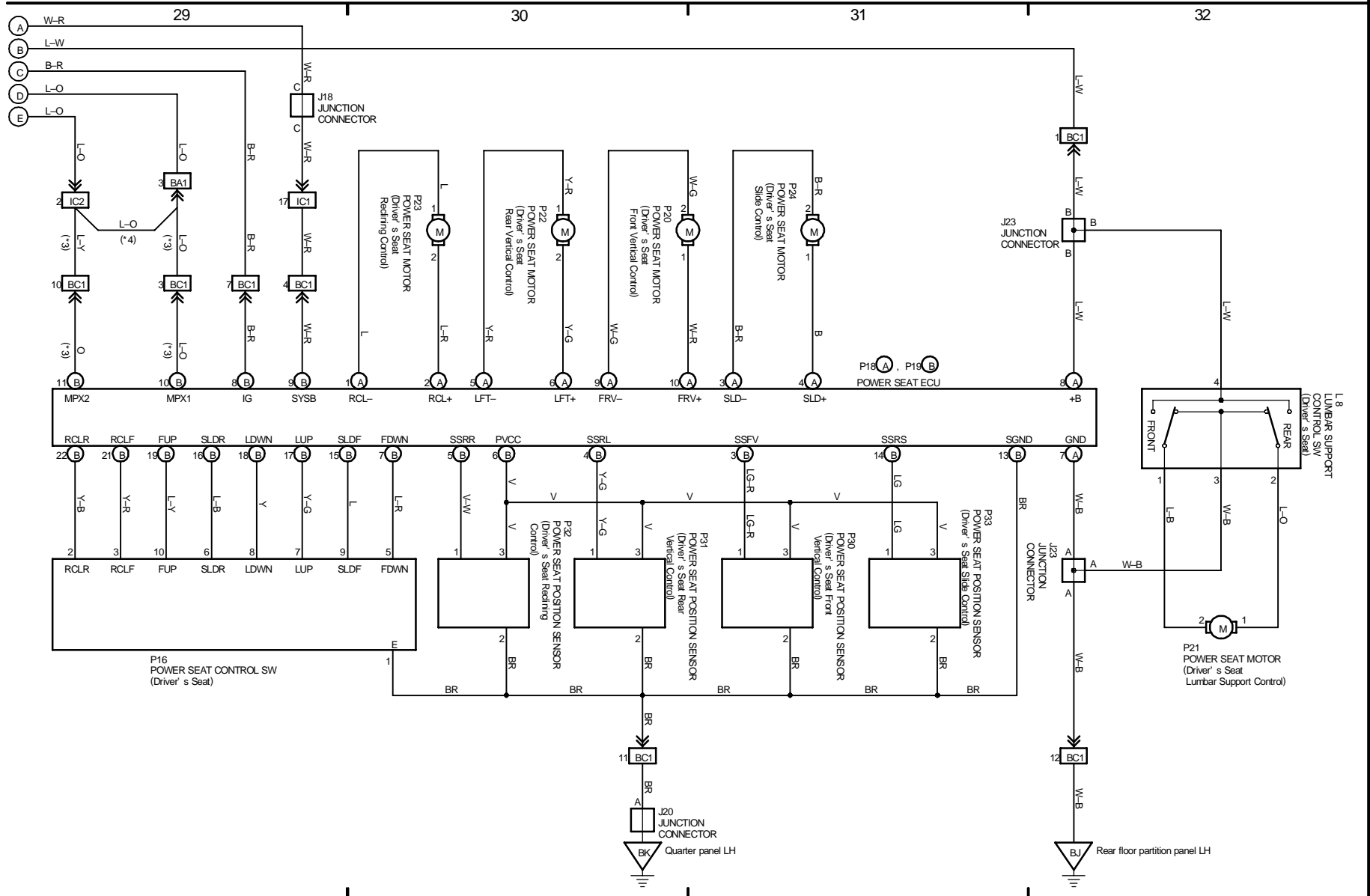

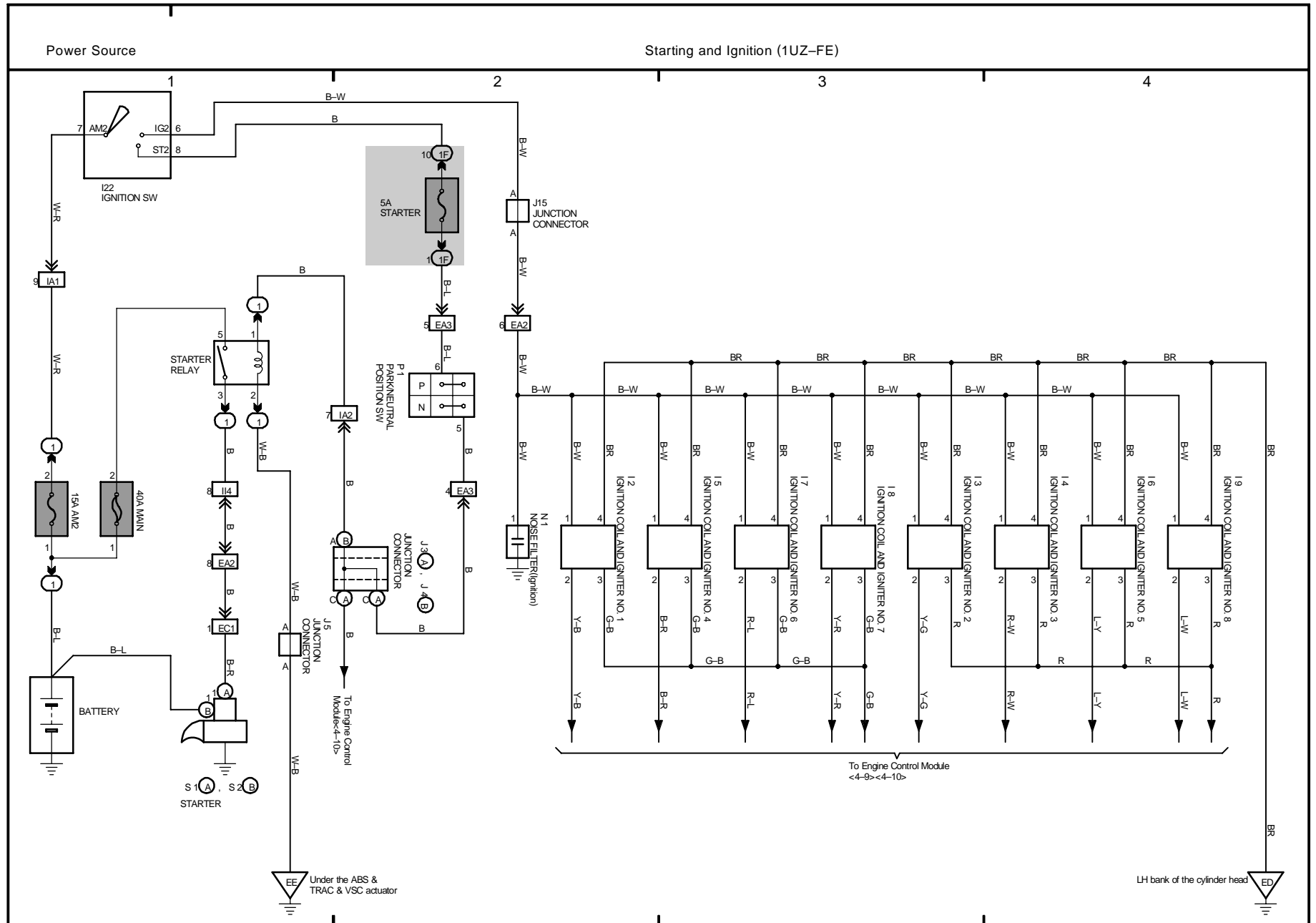

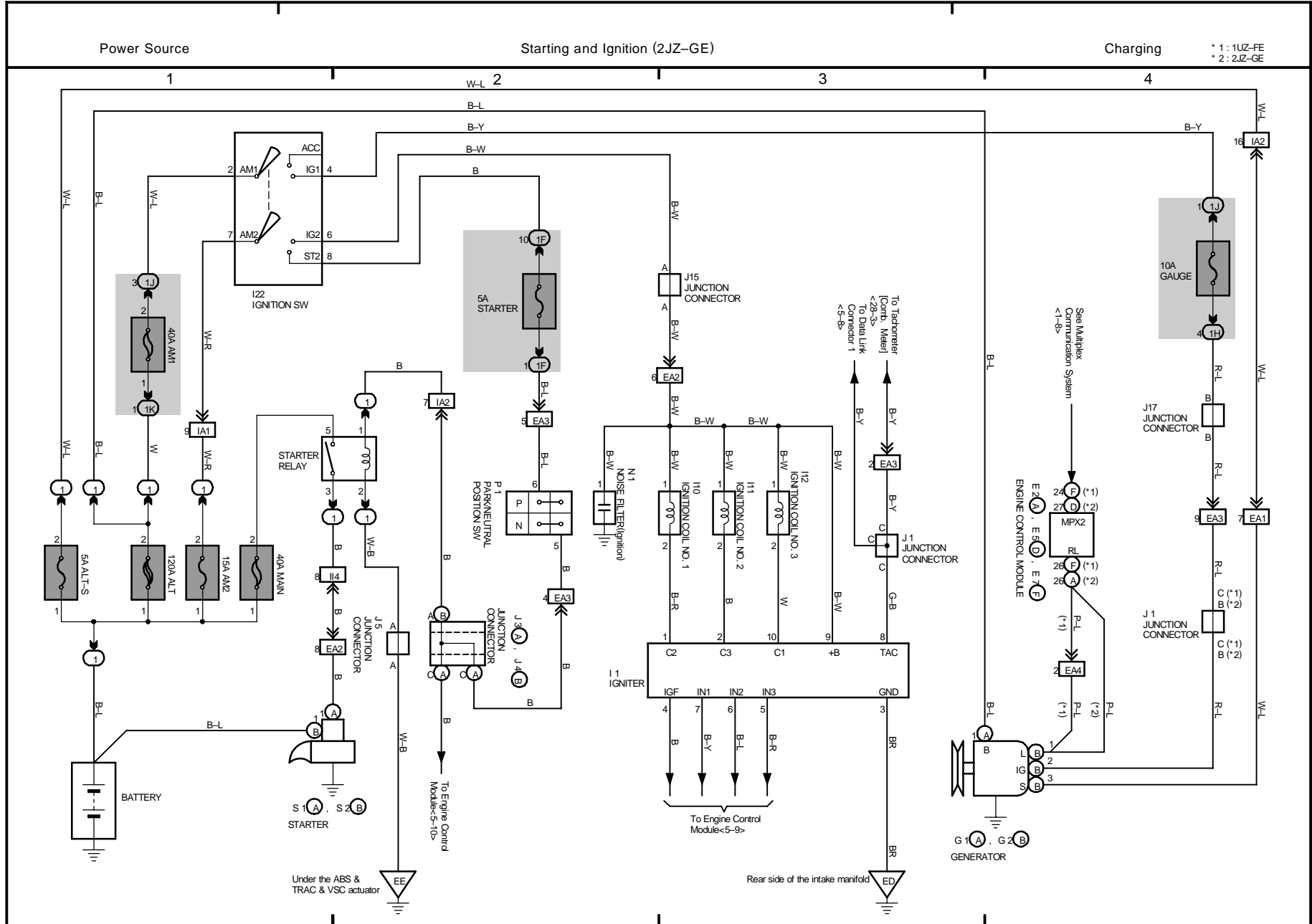

* 1: 1UZ-FE
* 2: 2JZ-GE

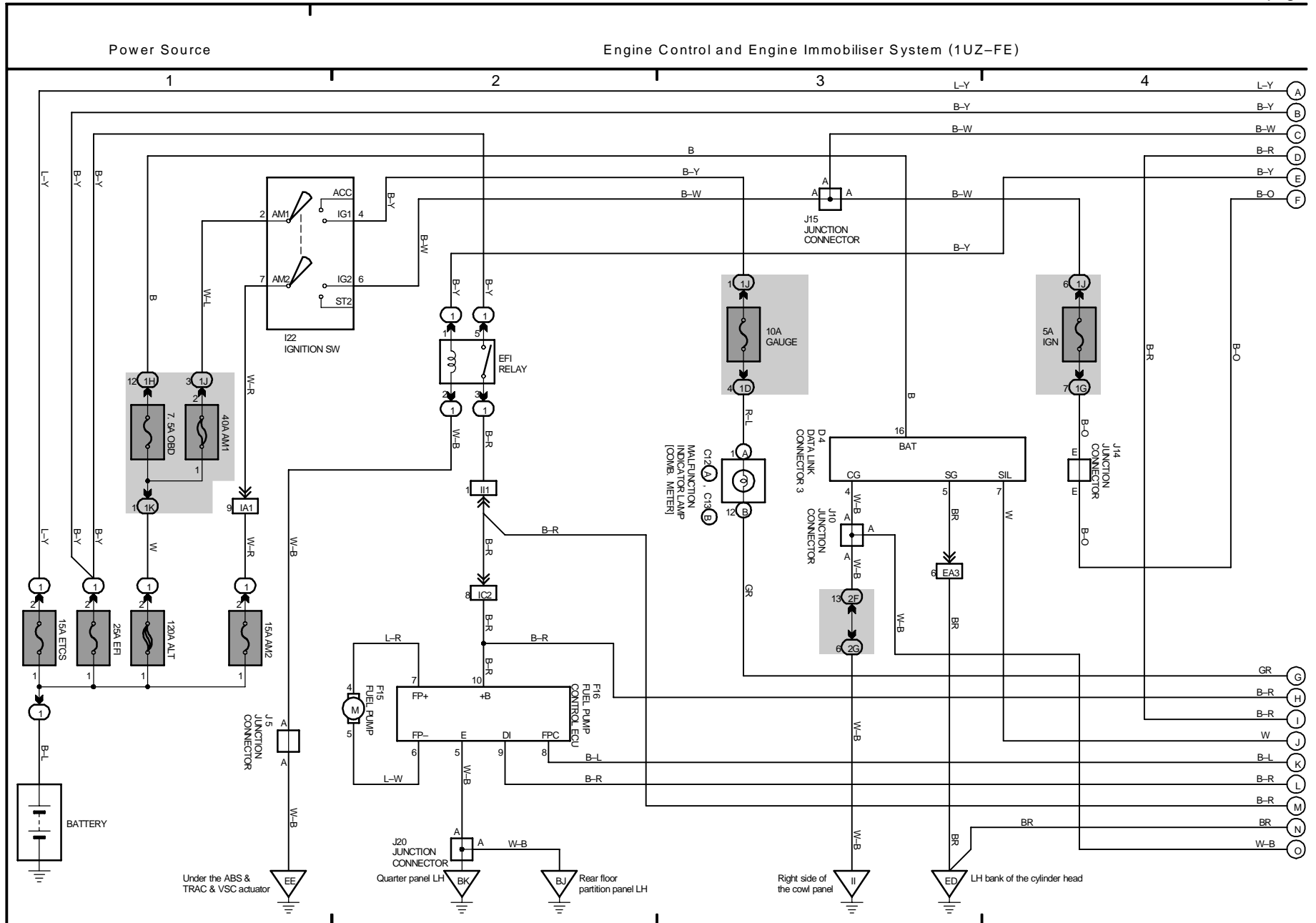

J OVERALL ELECTRICAL WIRING DIAGRAM

Engine Control and Engine Immobiliser System (1UZ-FE)

* 1: Shielded

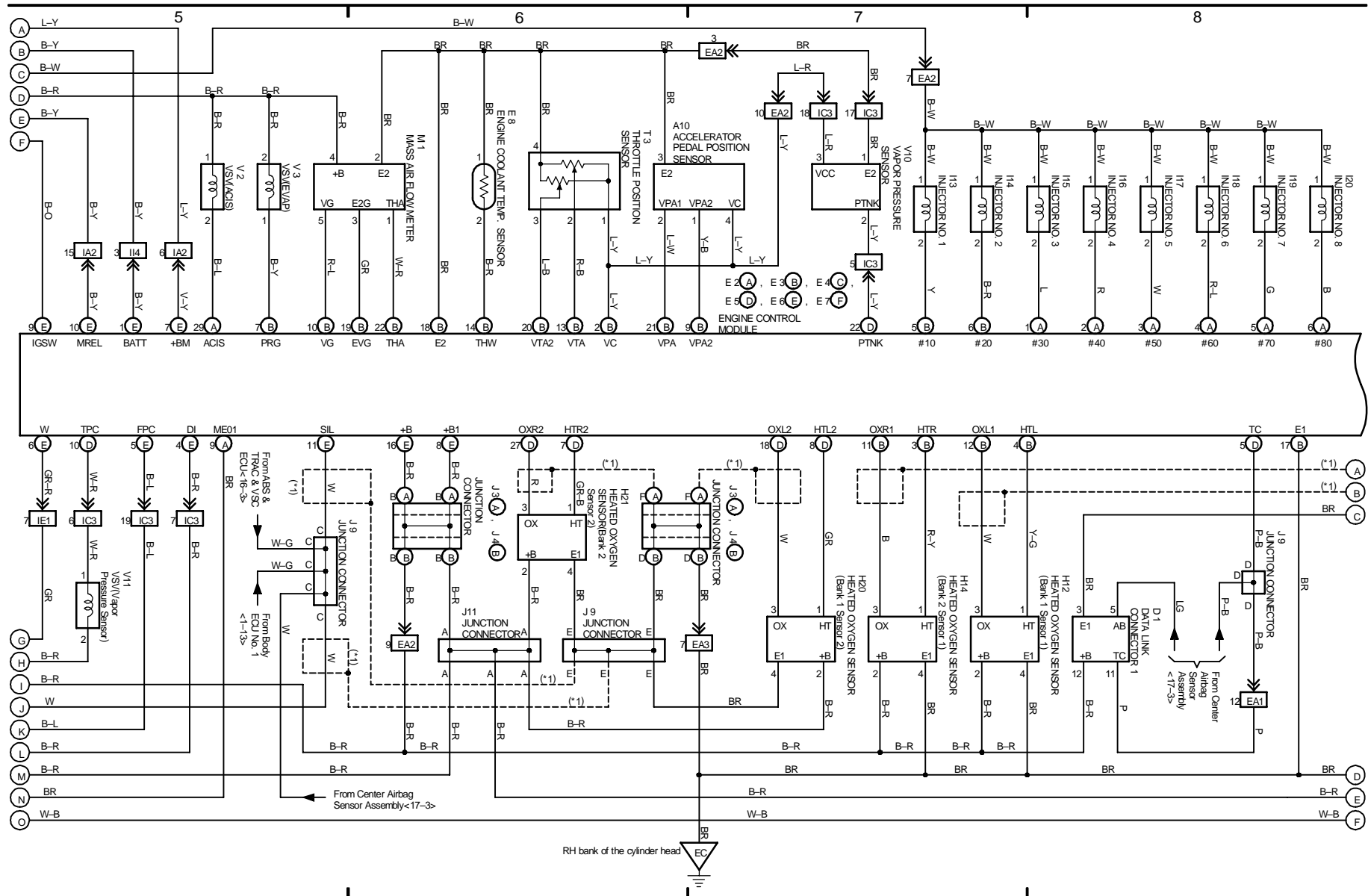

Engine Control and Engine Immobiliser System (1UZ-FE)

* 1: Shielded

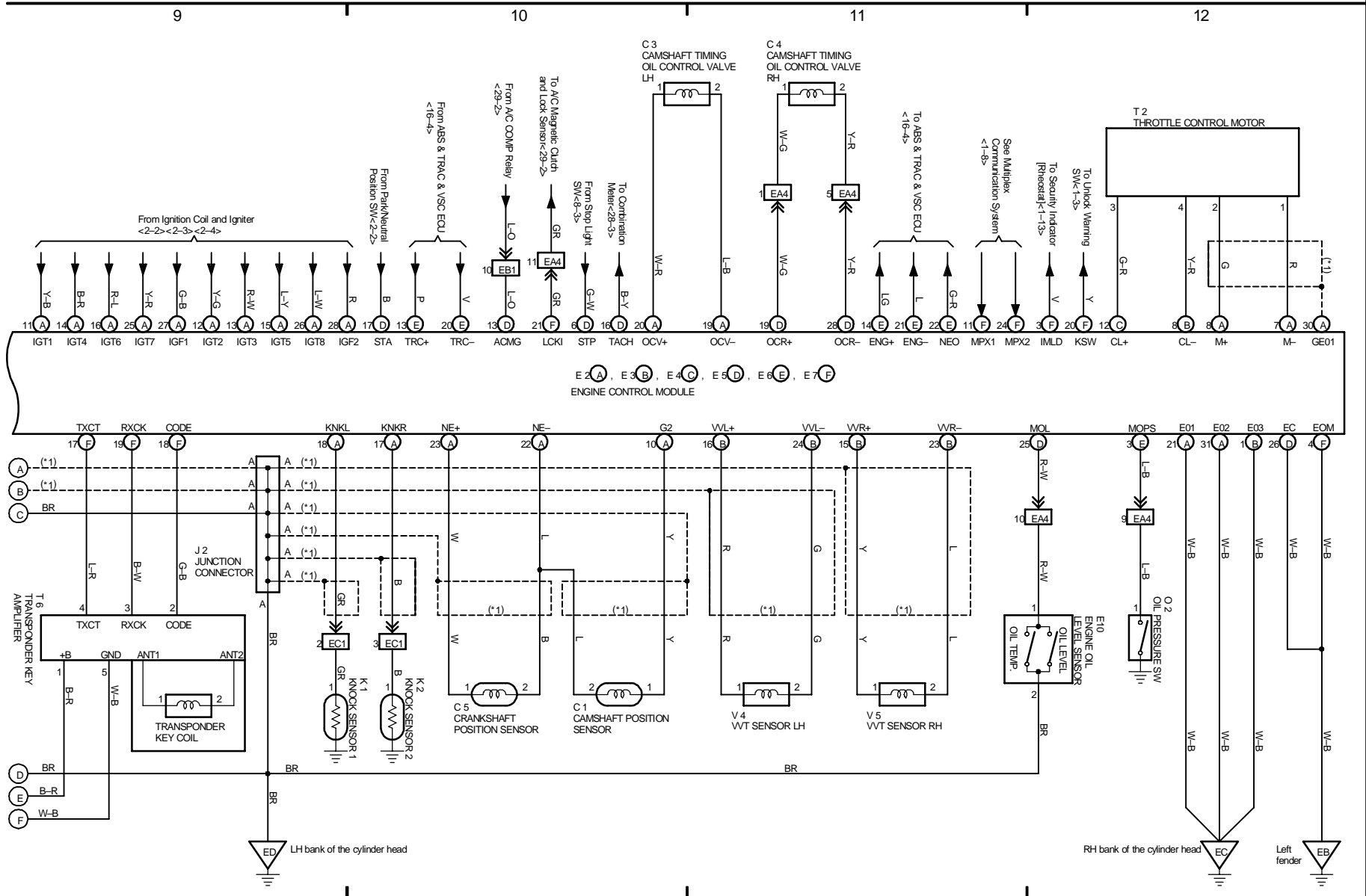

J OVERALL ELECTRICAL WIRING DIAGRAM

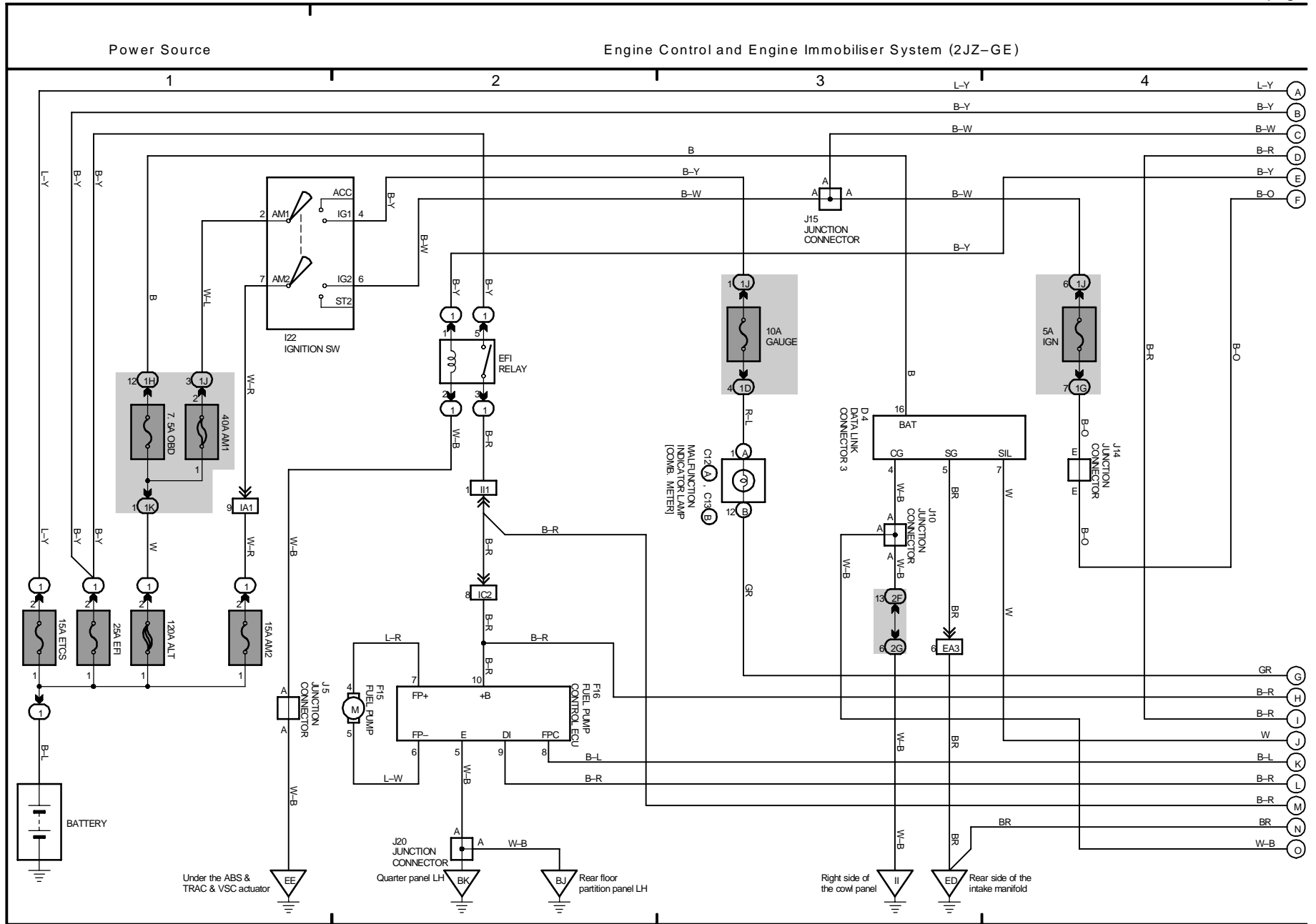

Engine Control and Engine Immobiliser System (2JZ-GE)

* 1: Shielded

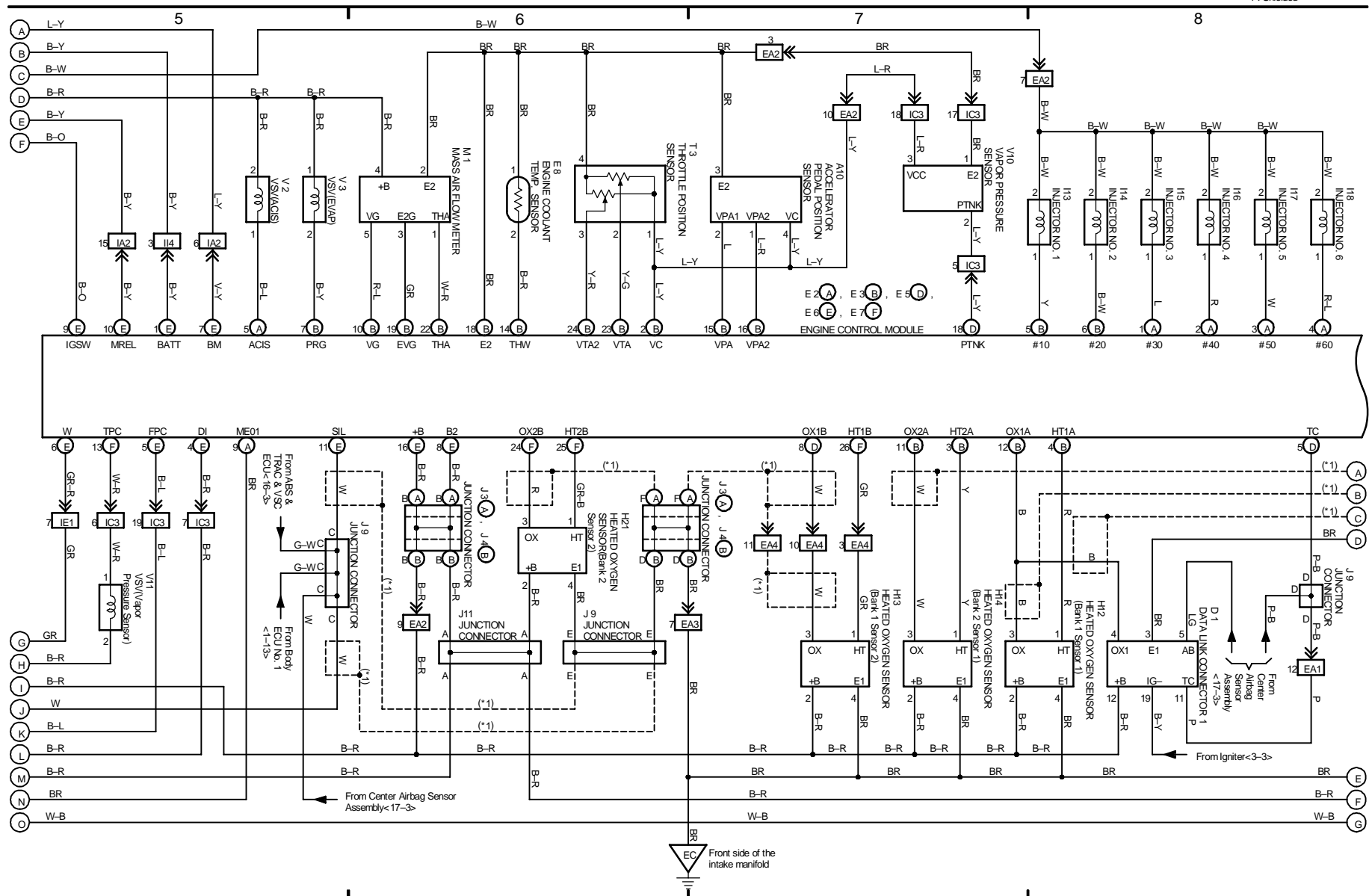

Engine Control and Engine Immobiliser System (2JZ-GE)

- * 1 : Shielded
- * 2 : w/ Daytime Running Light
- * 3 : w/o Daytime Running Light

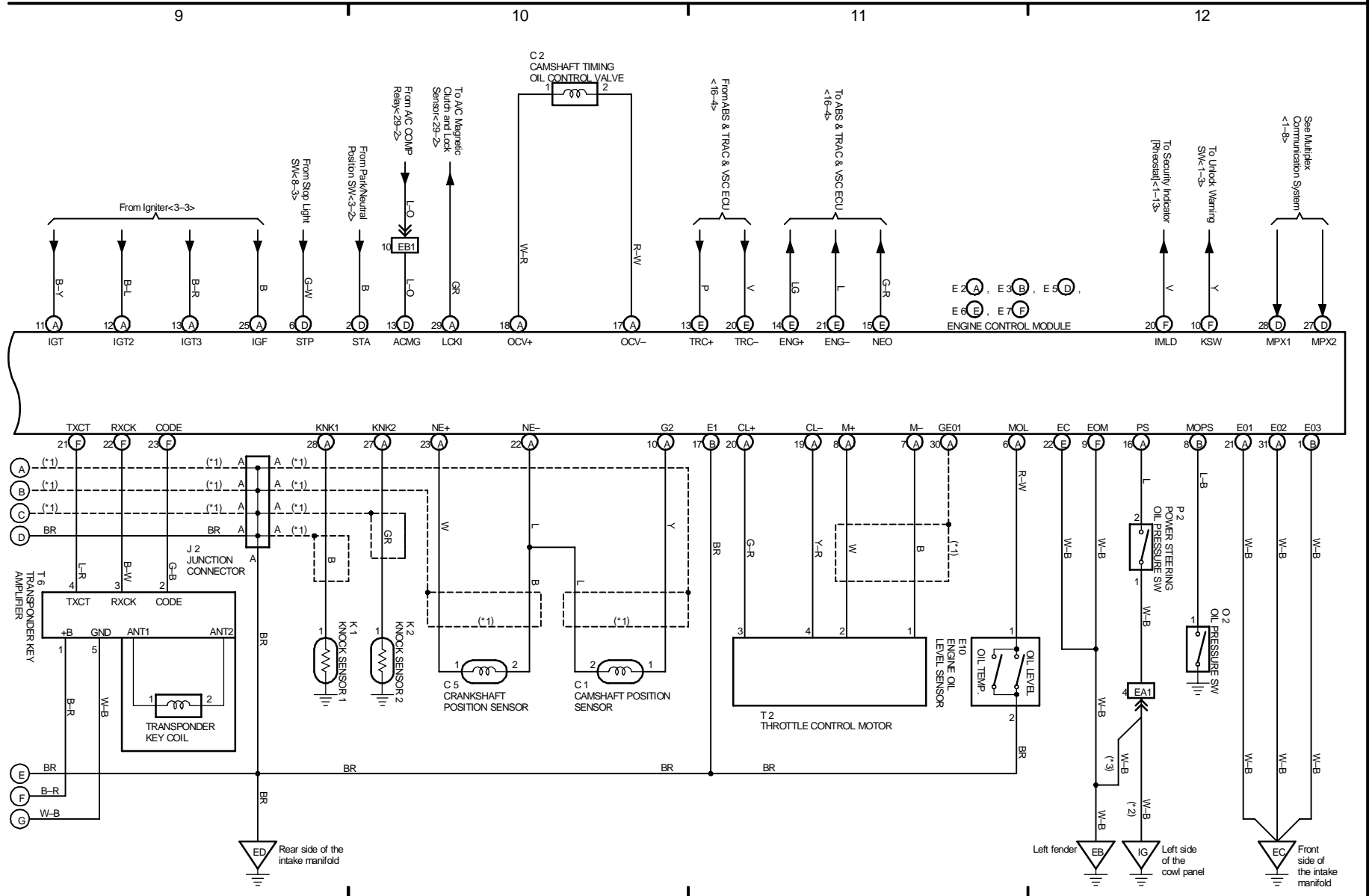

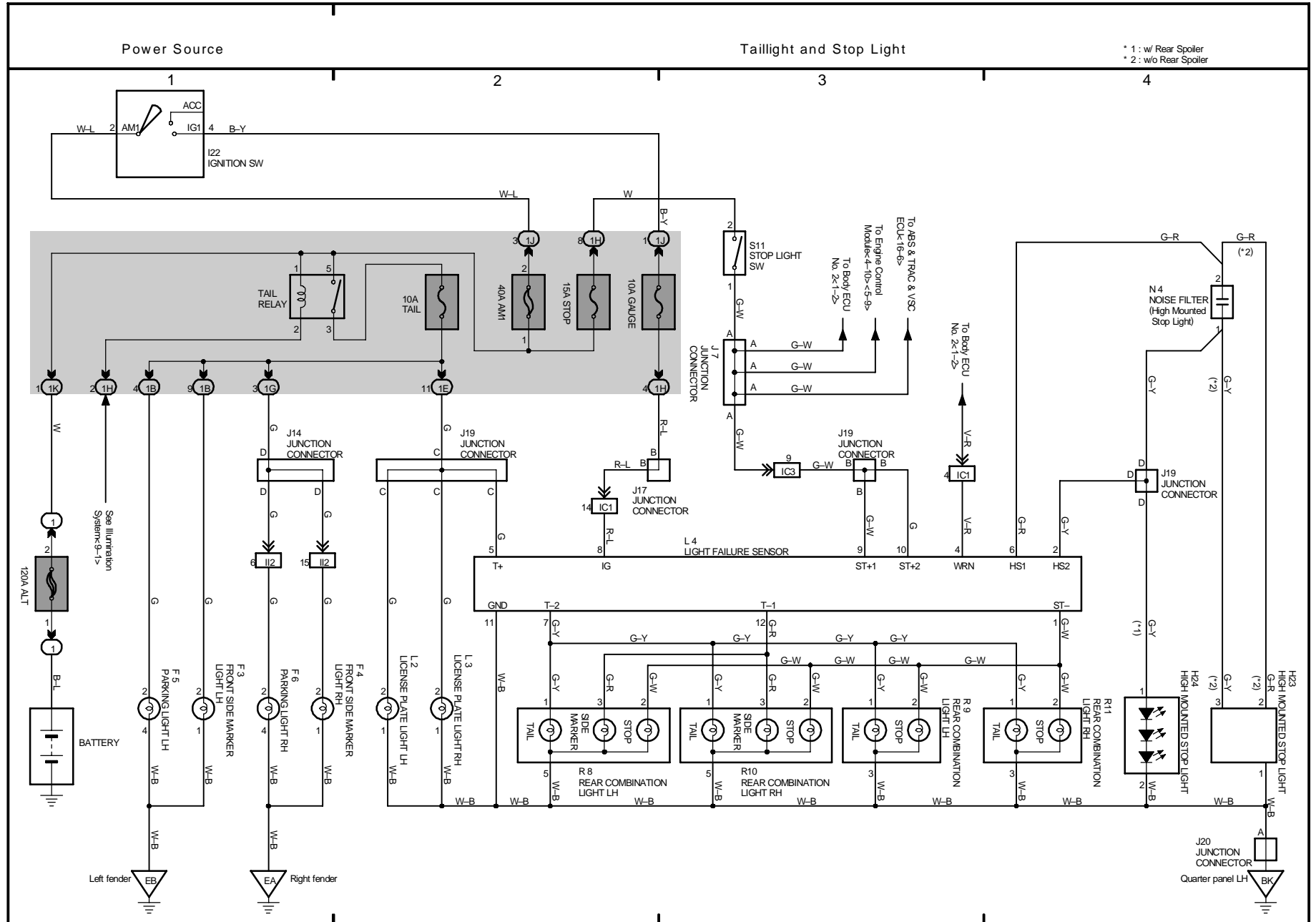

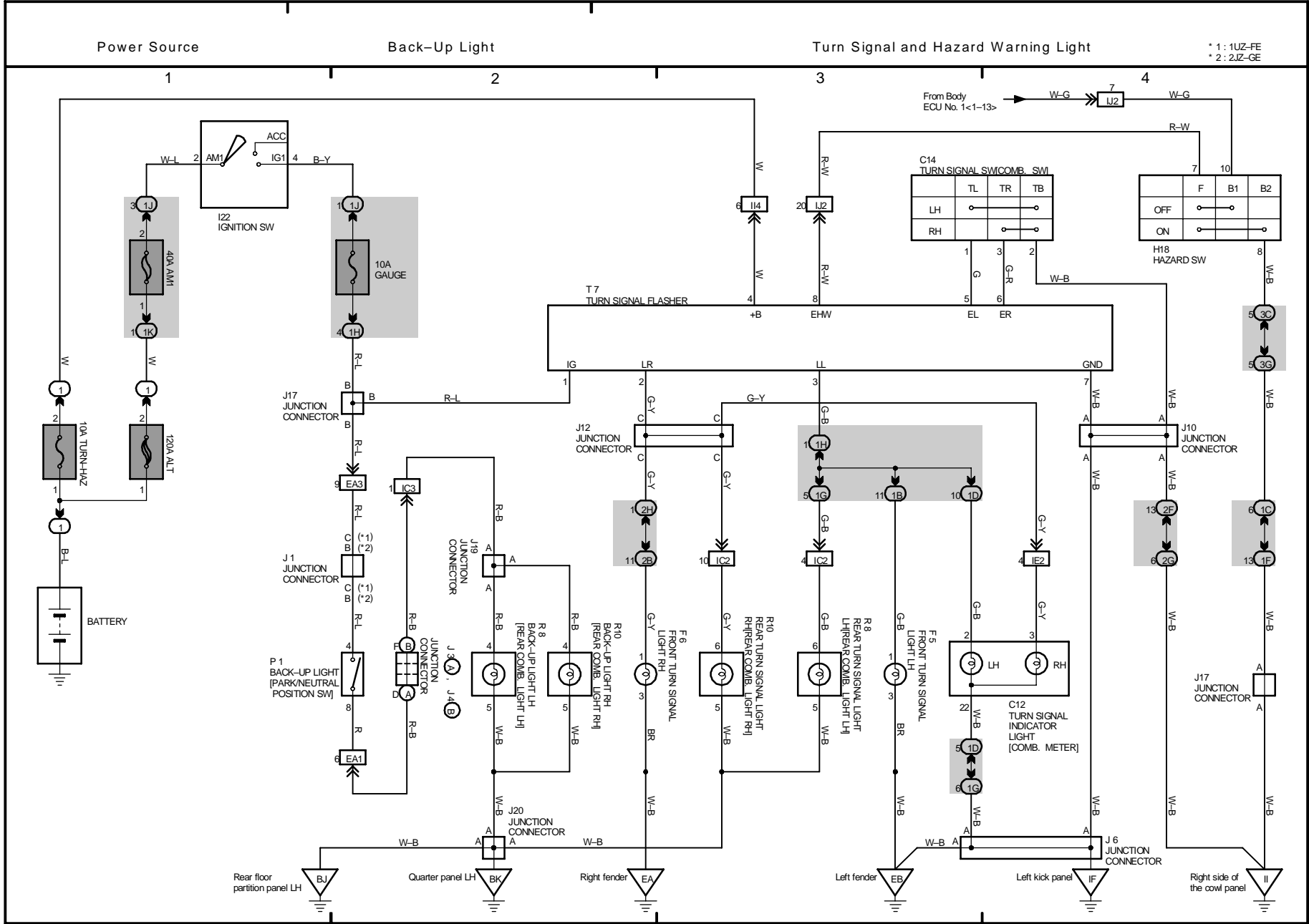

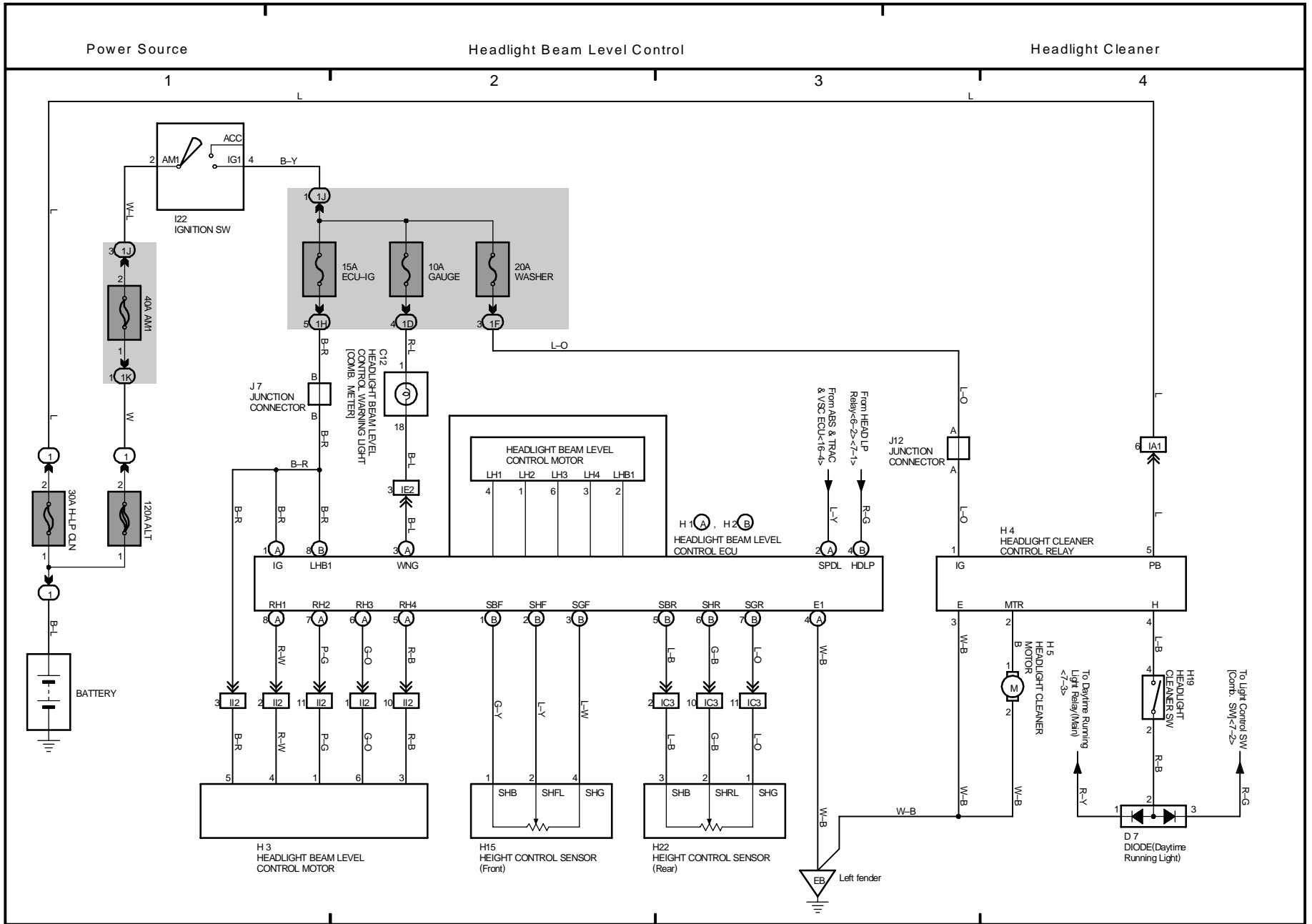

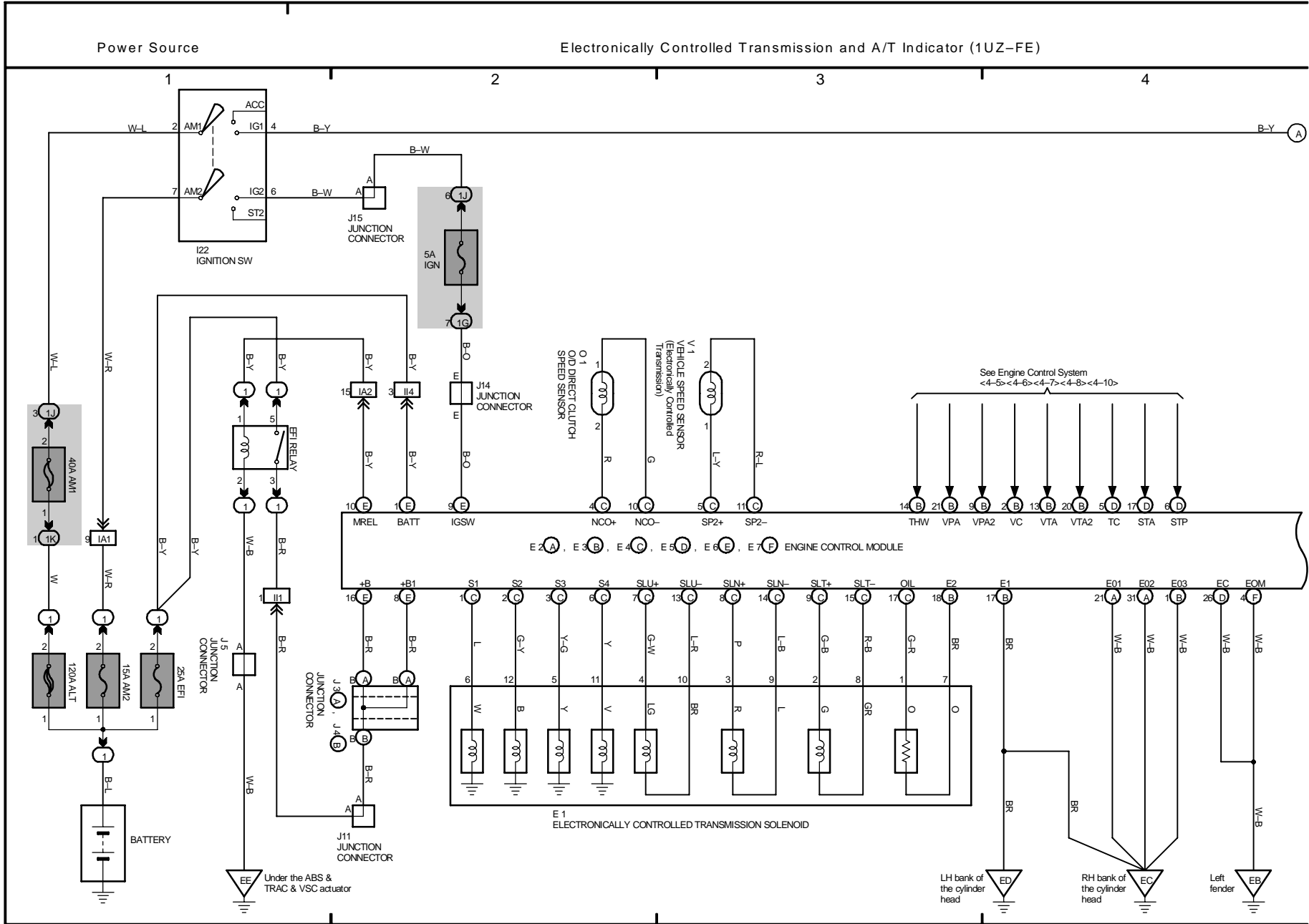

J OVERALL ELECTRICAL WIRING DIAGRAM

Electronically Controlled Transmission and A/T Indicator (1UZ-FE)

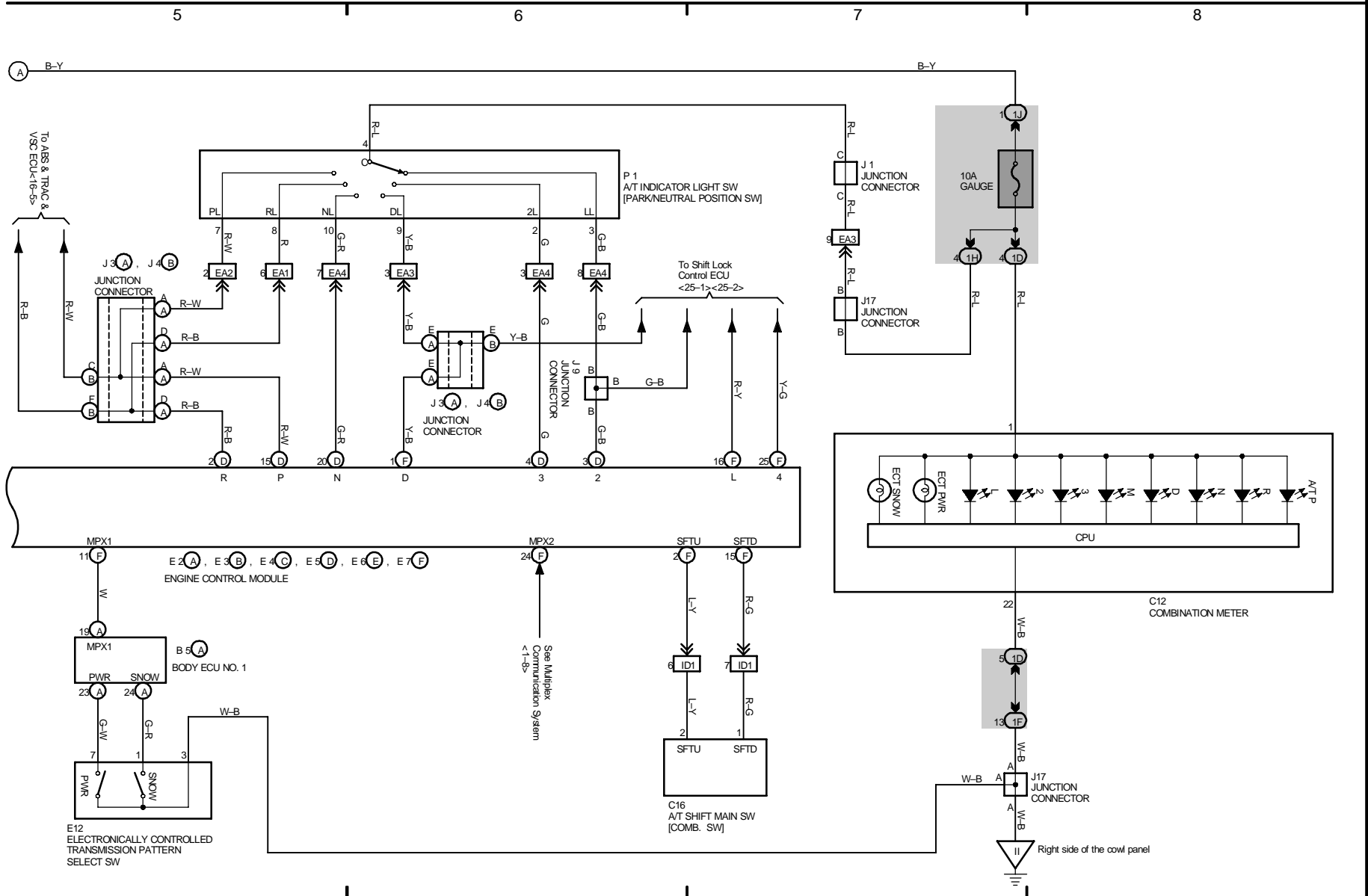

Electronically Controlled Transmission and A/T Indicator (2JZ-GE)

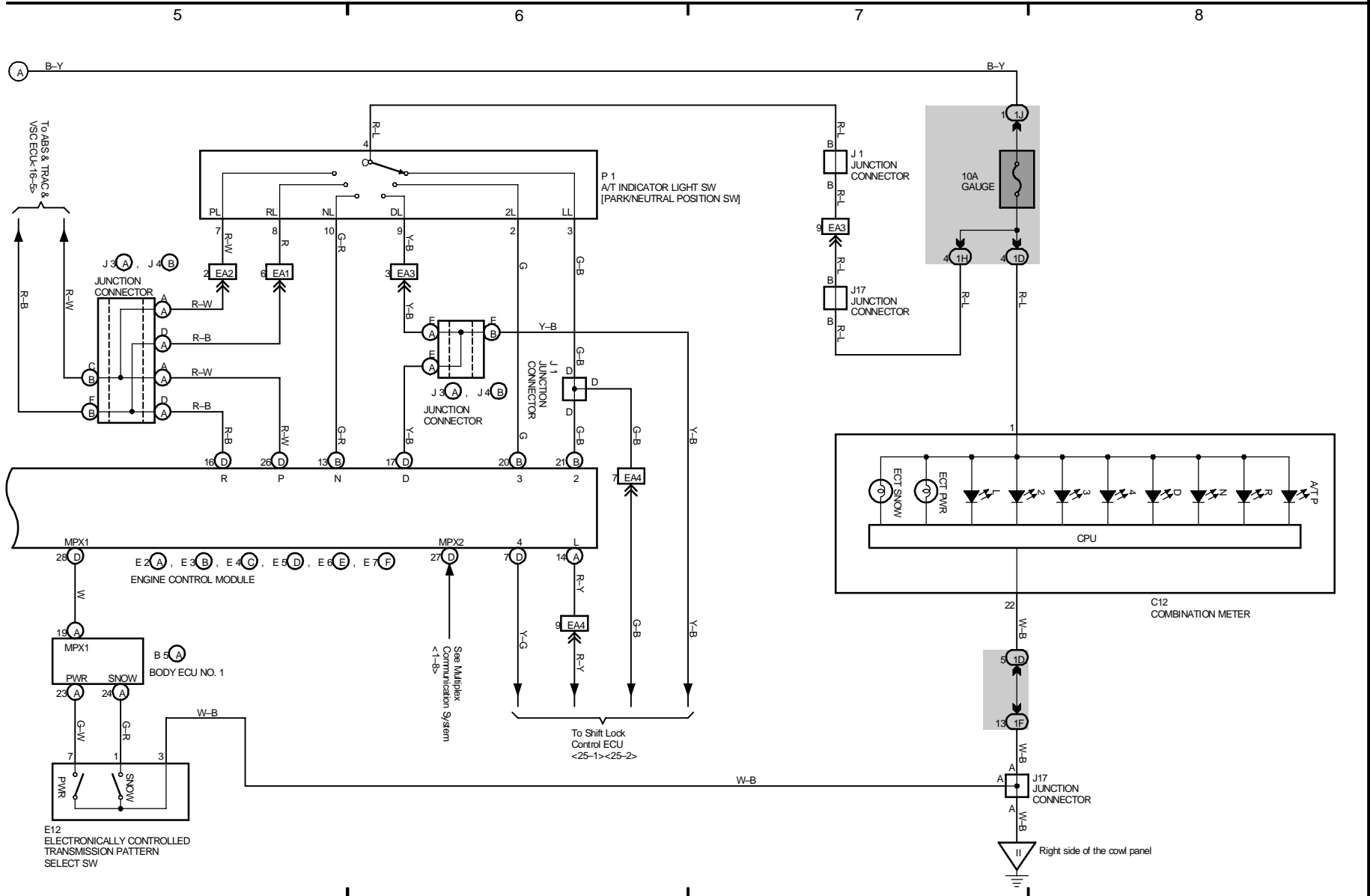

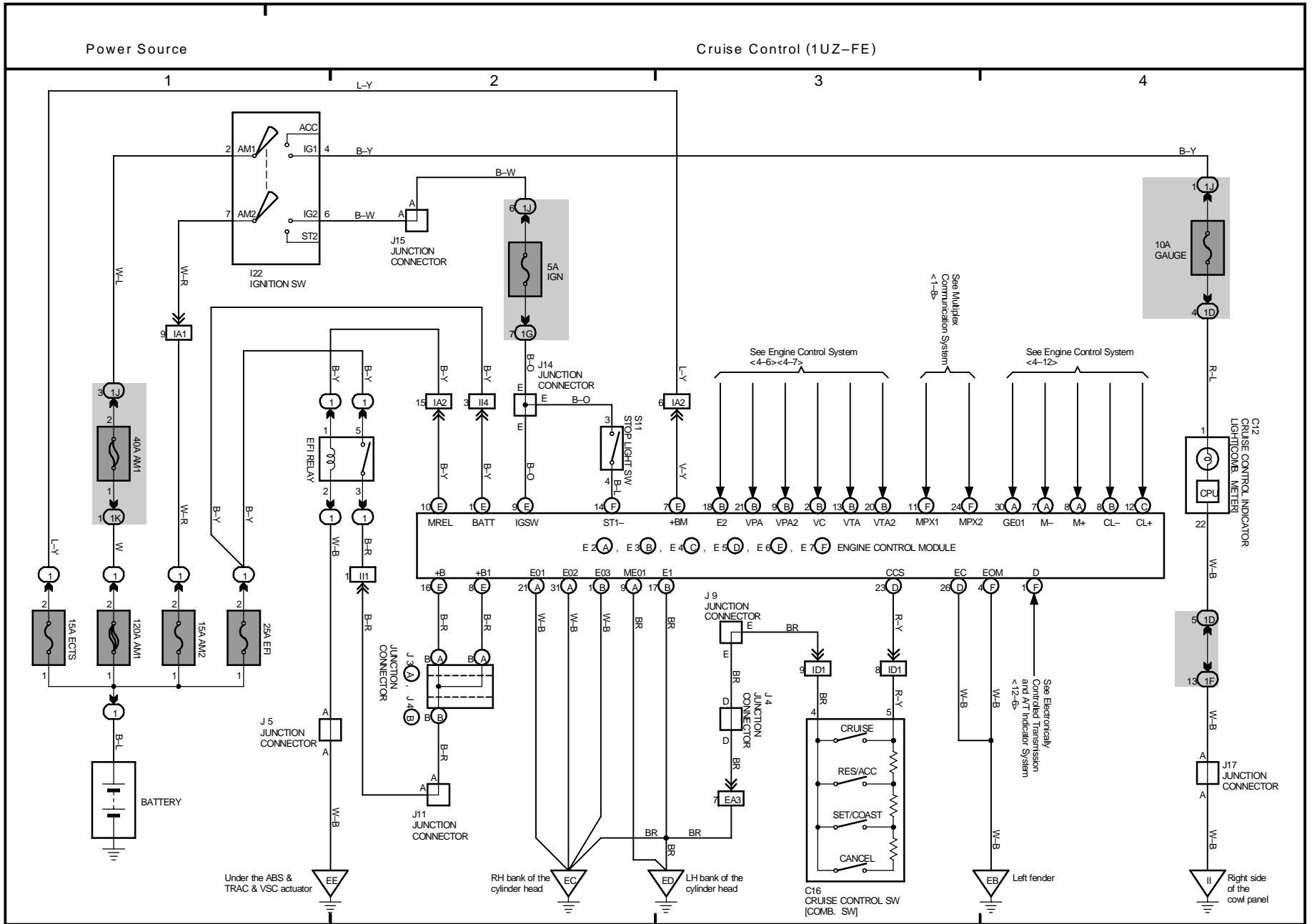

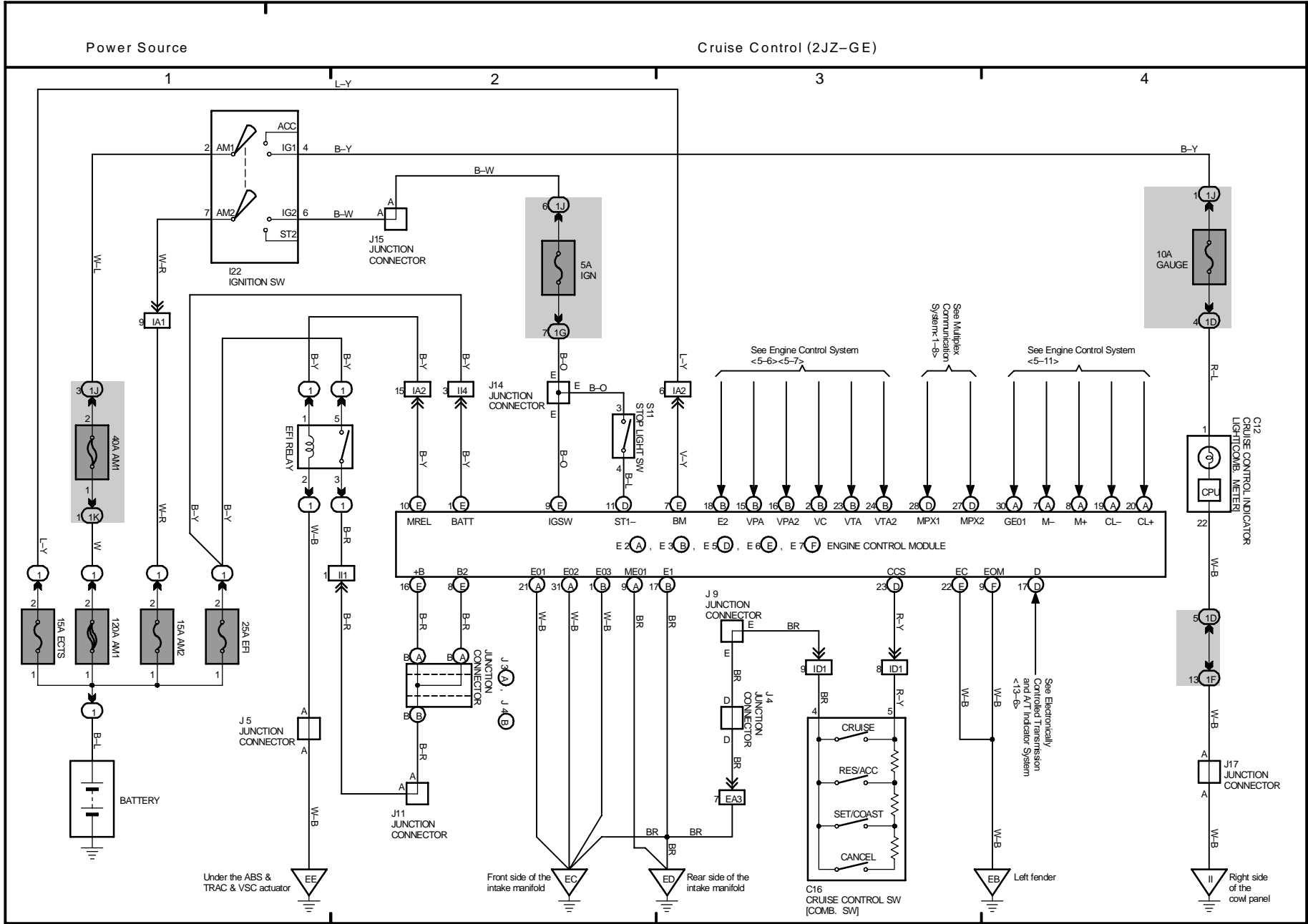

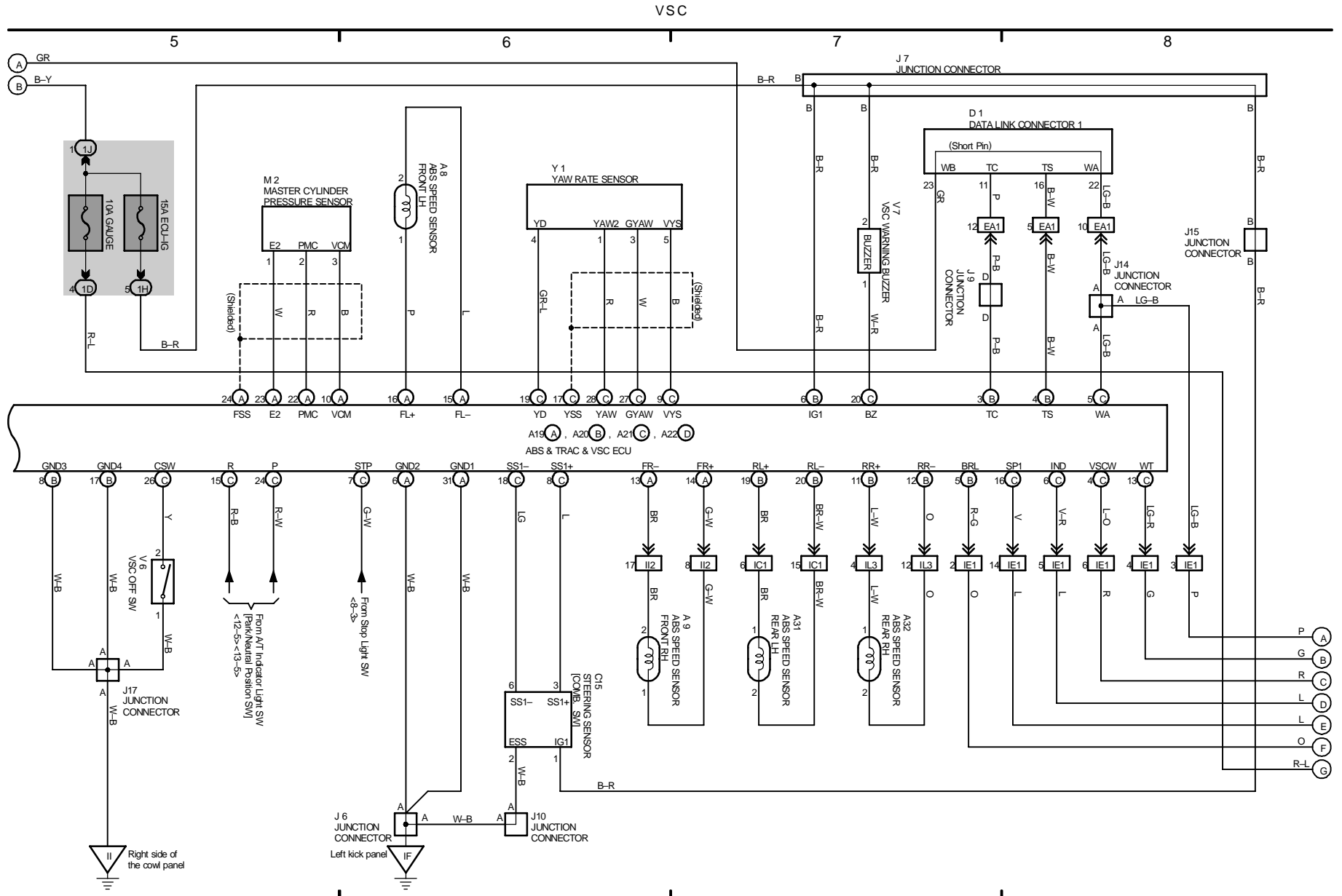

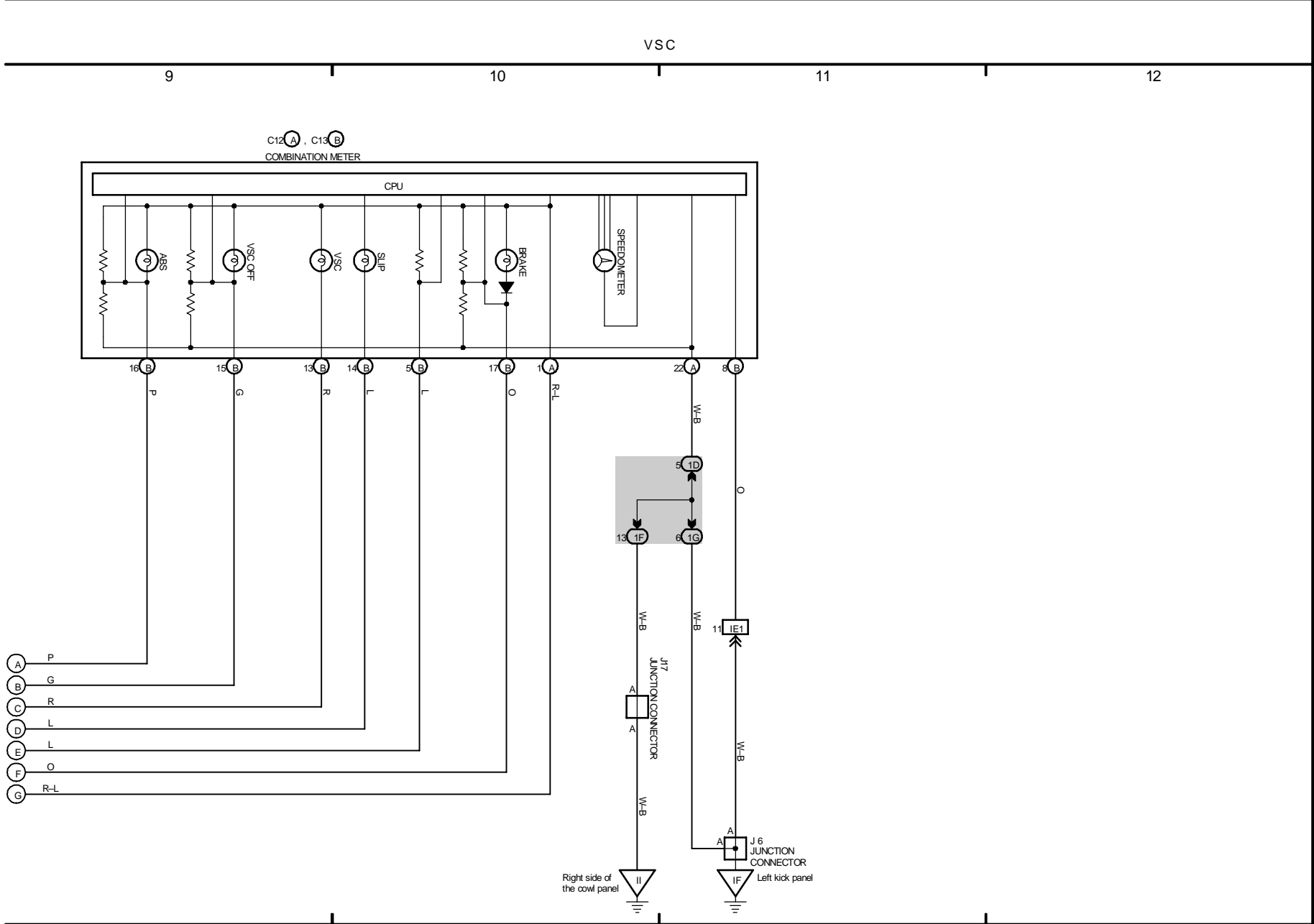

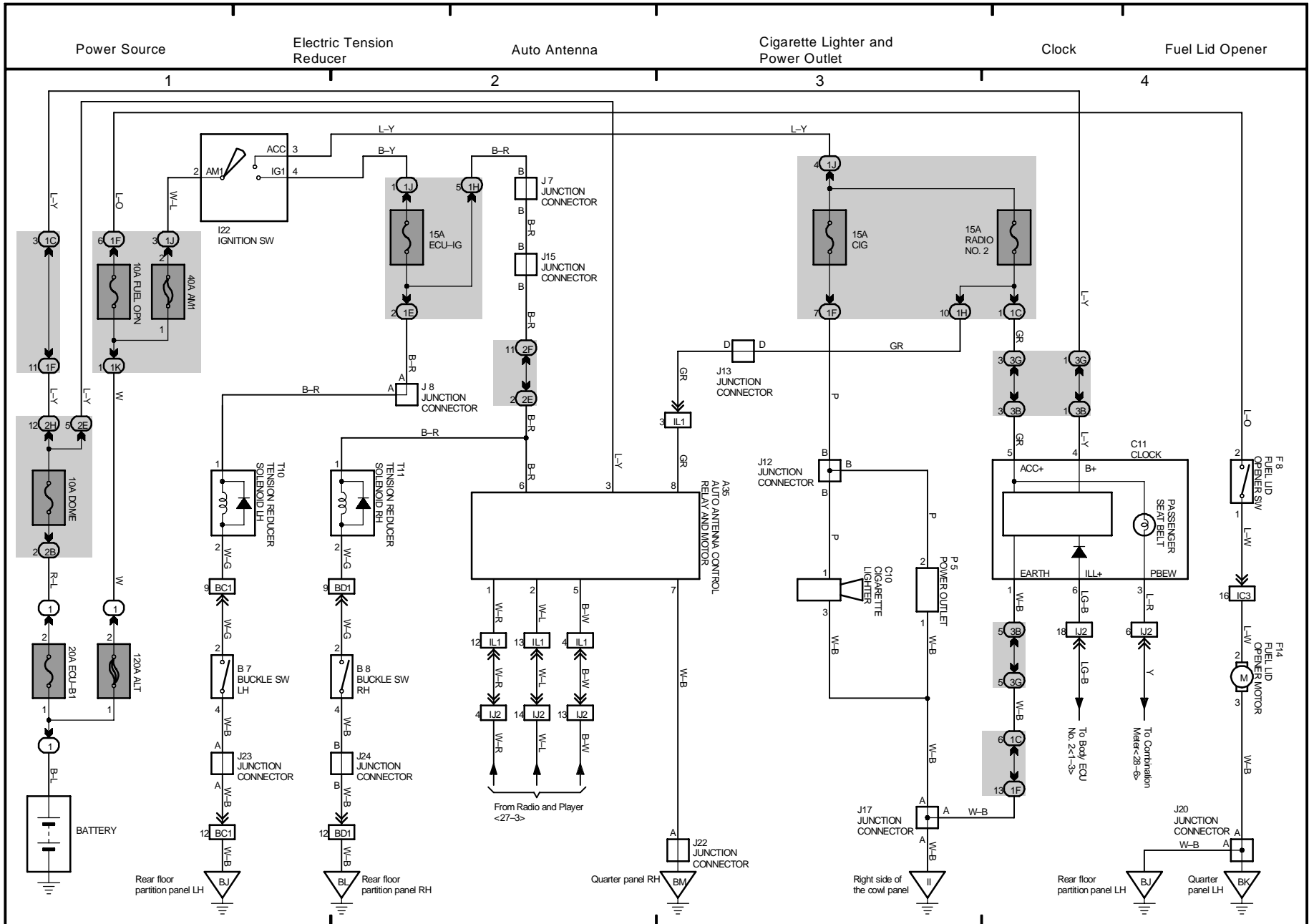

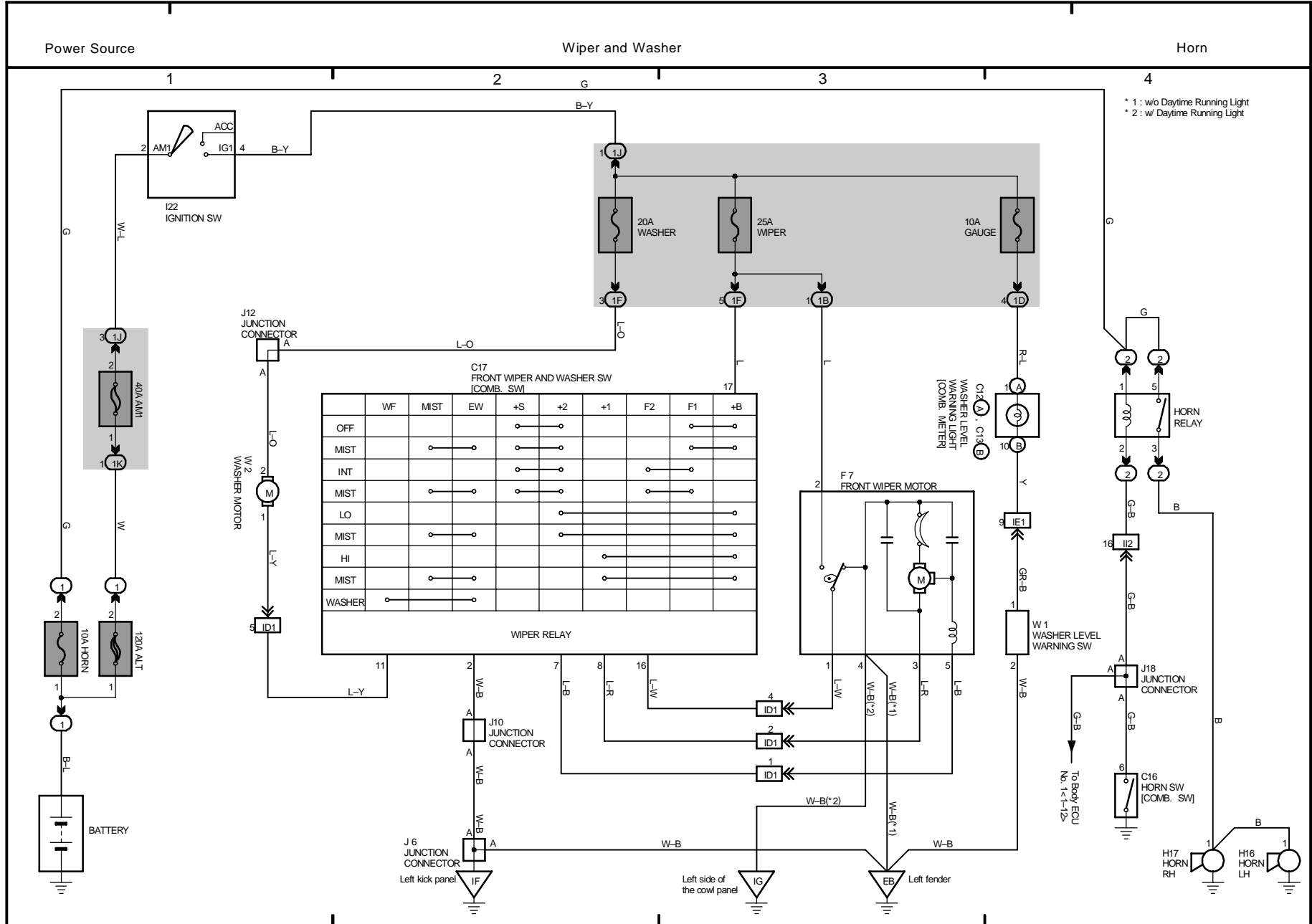

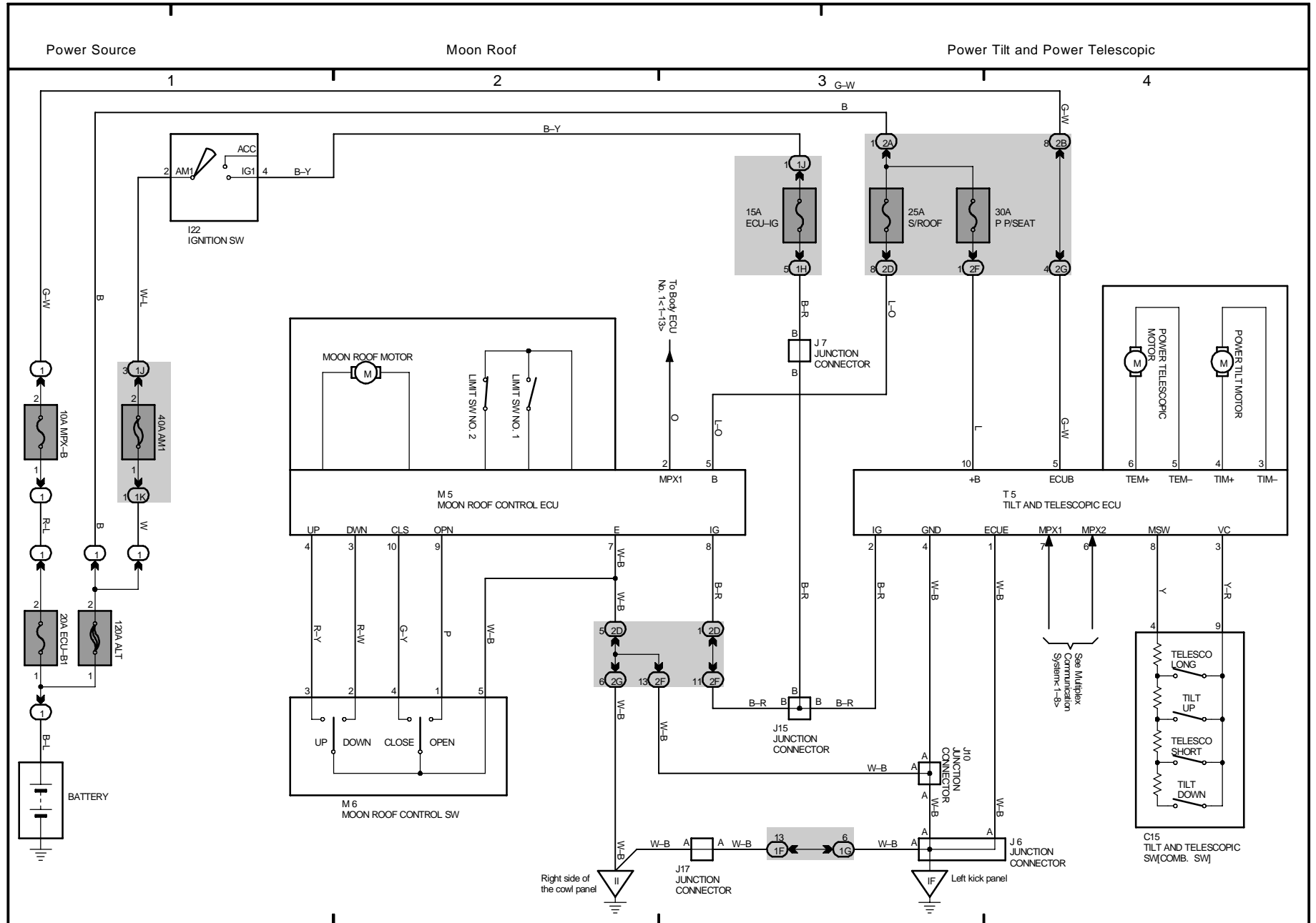

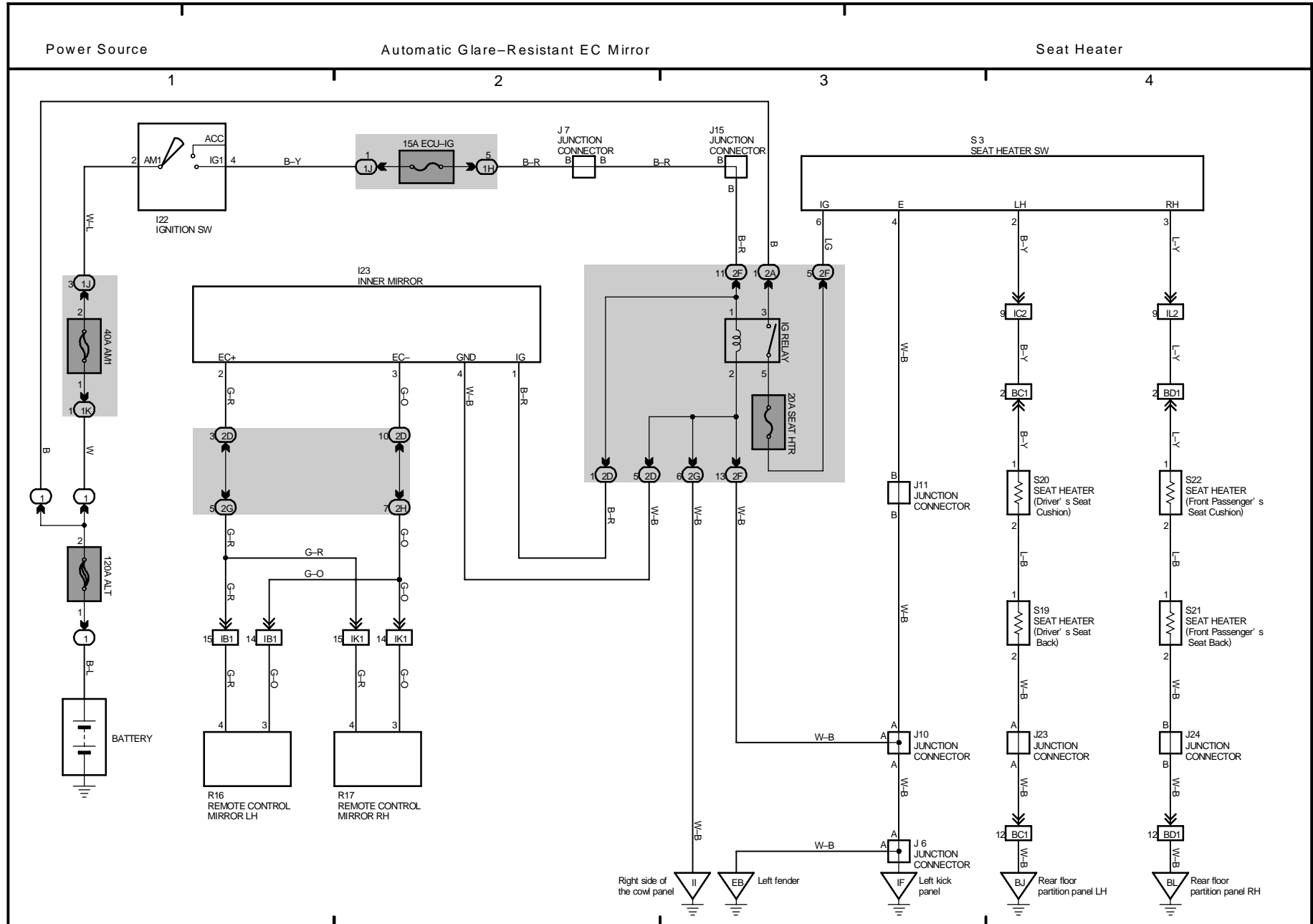

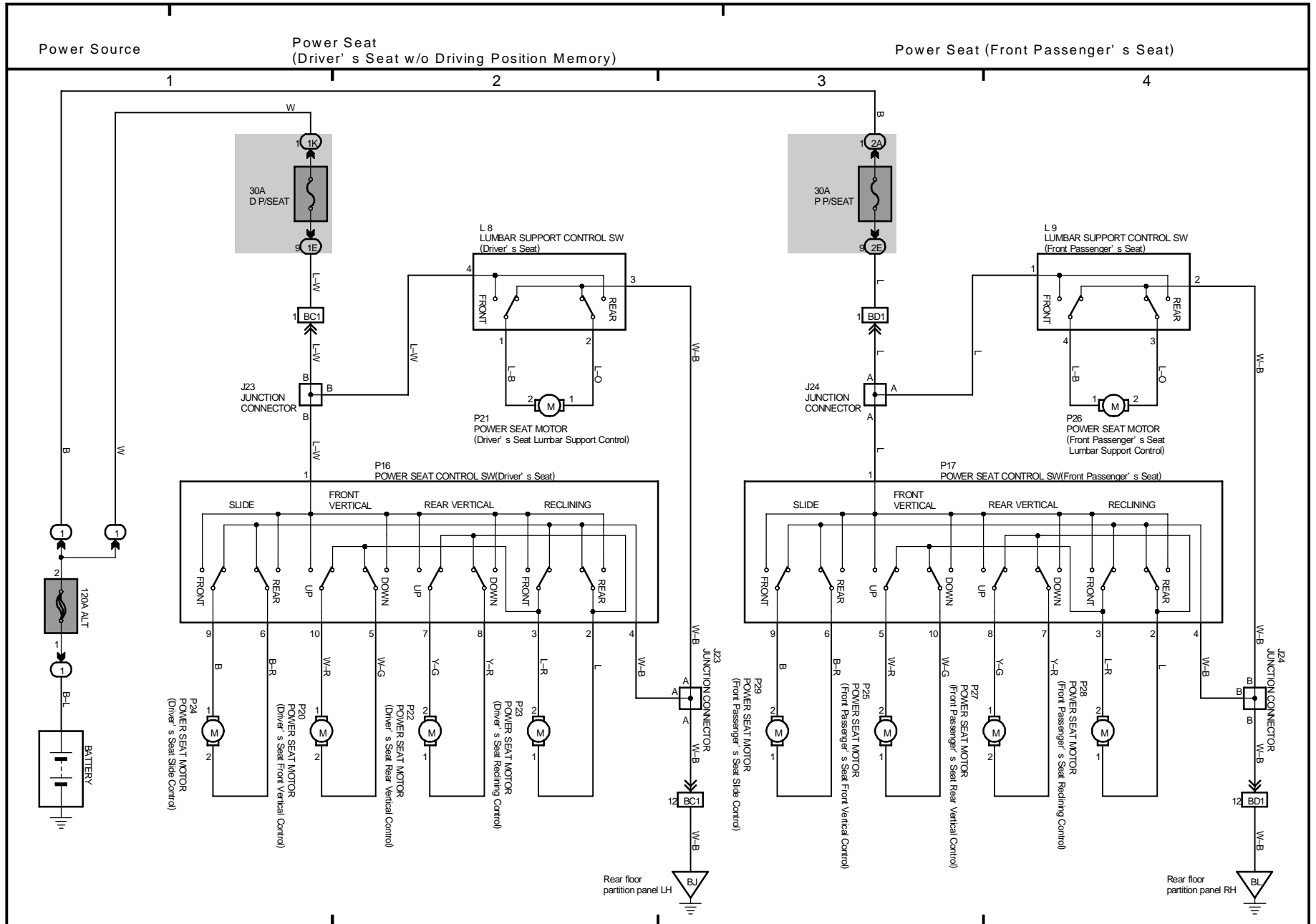

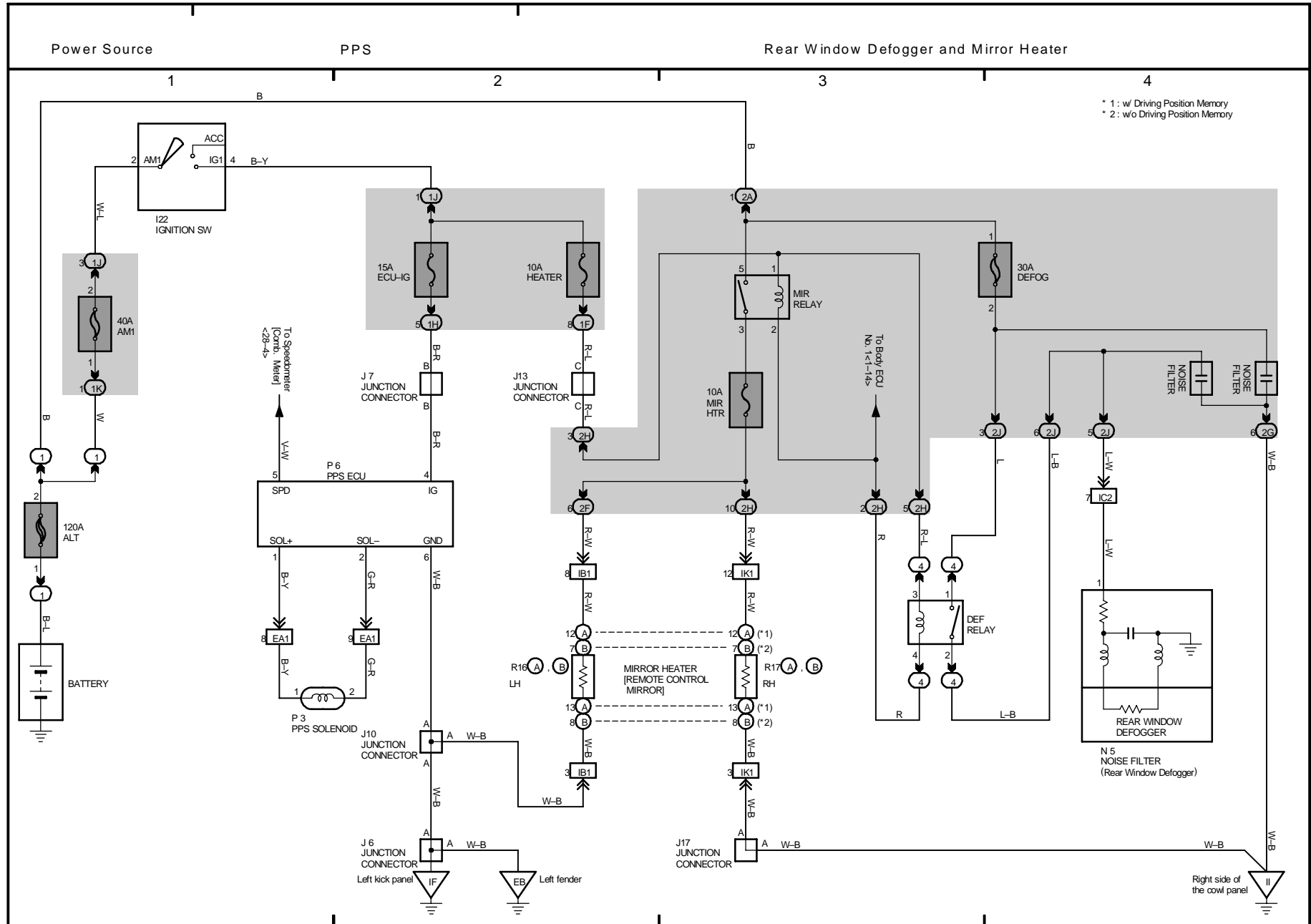

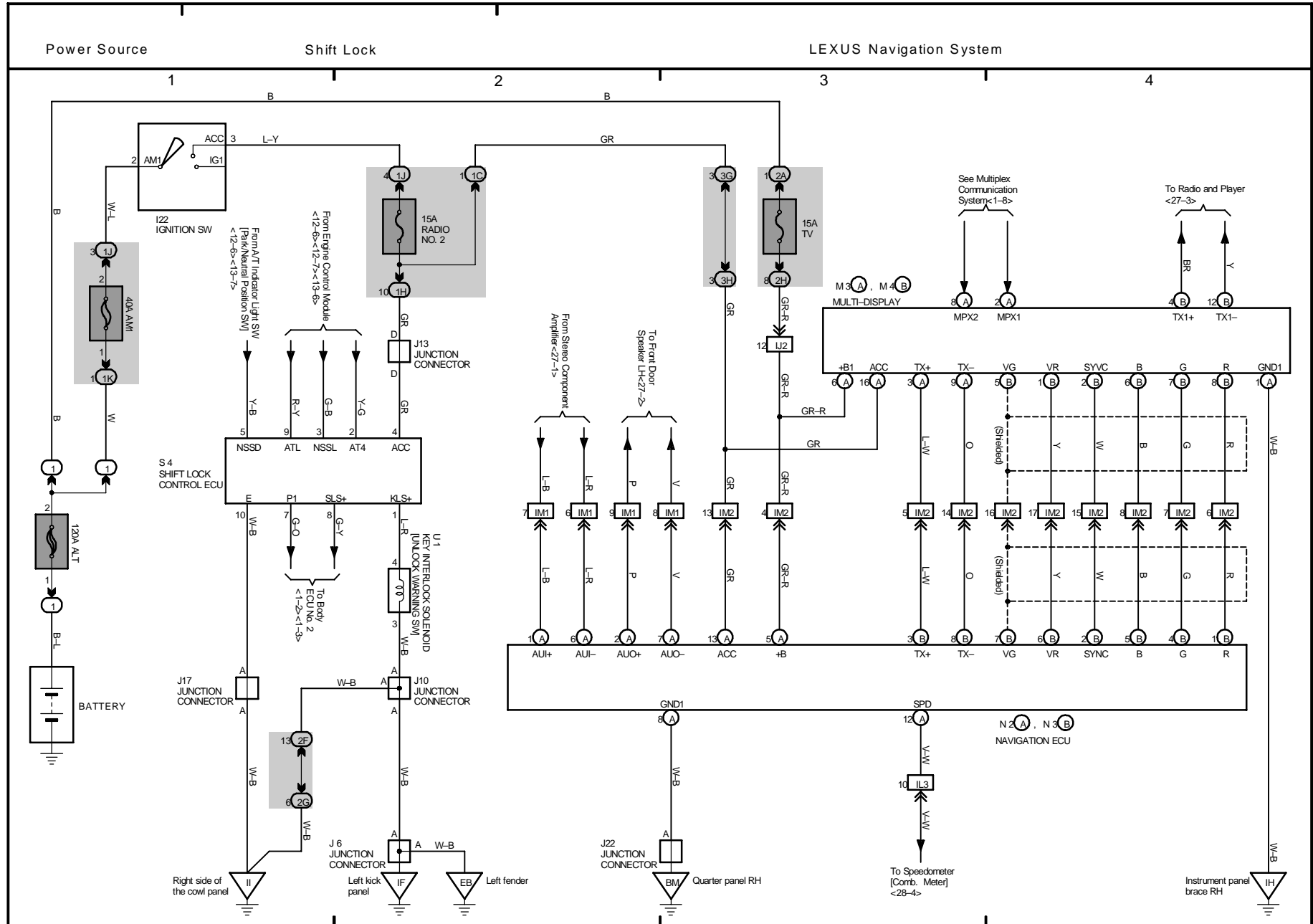

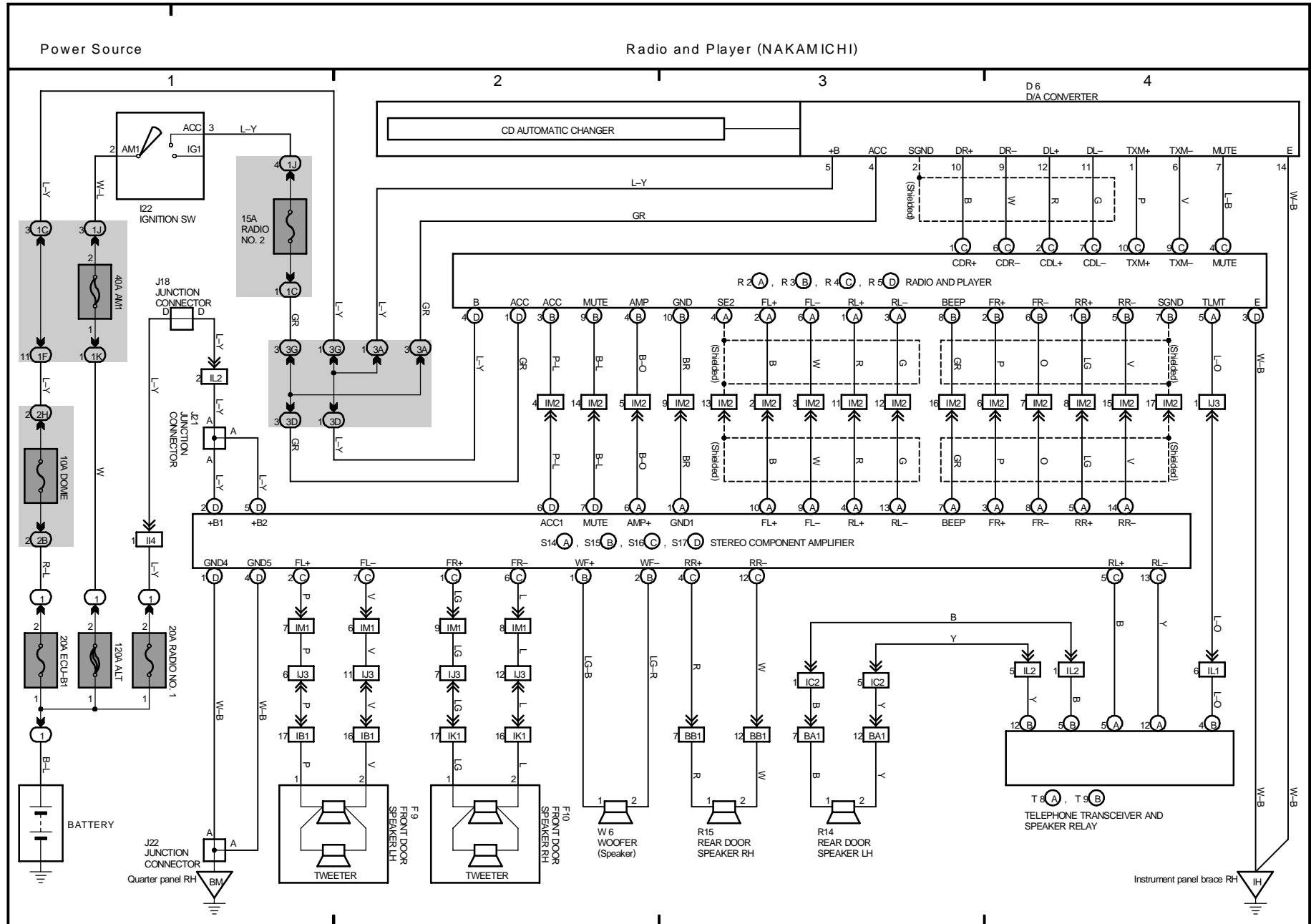

Combination Meter

* 3 : USA
* 4 : Canada, Taiwan

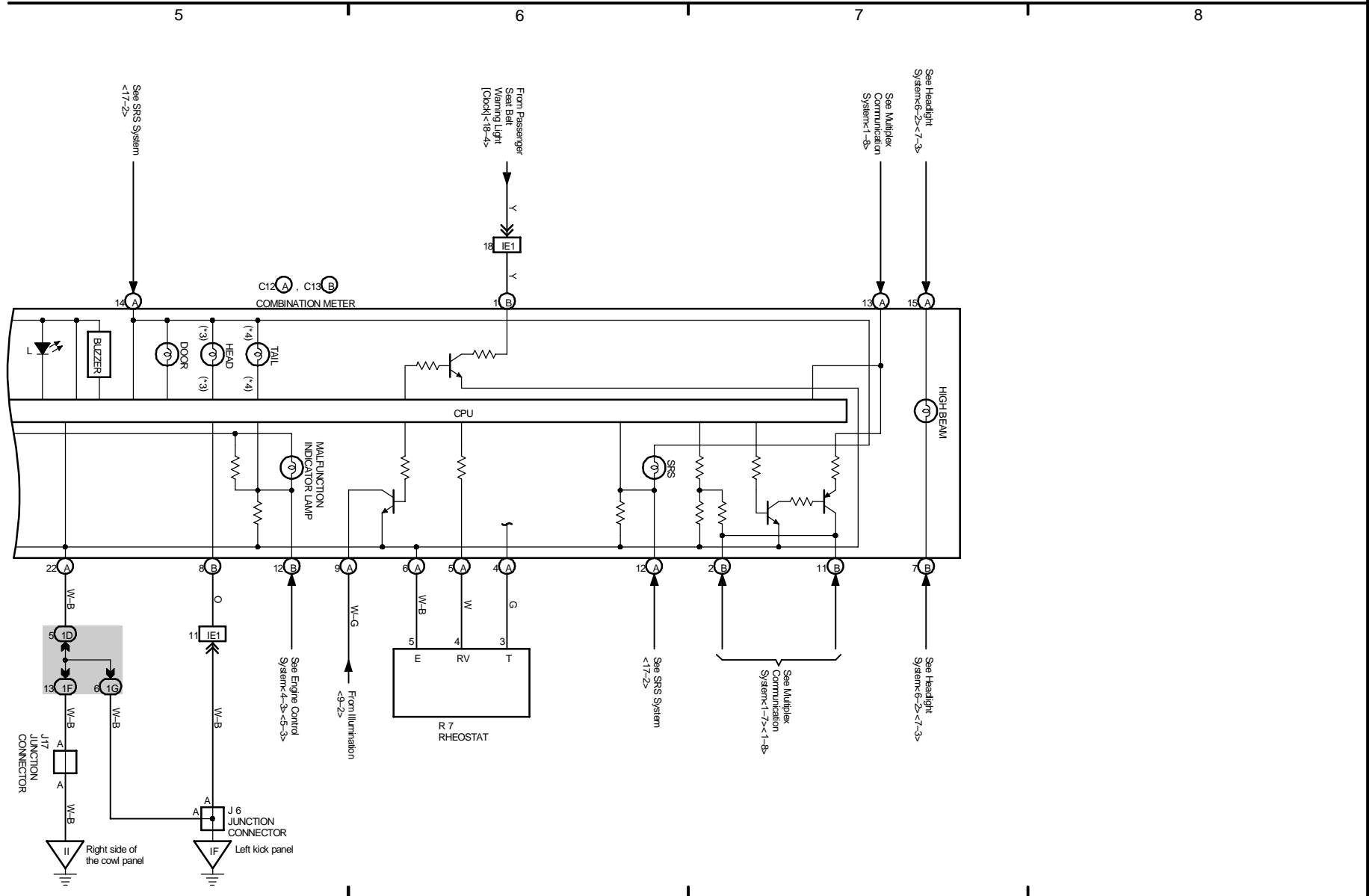

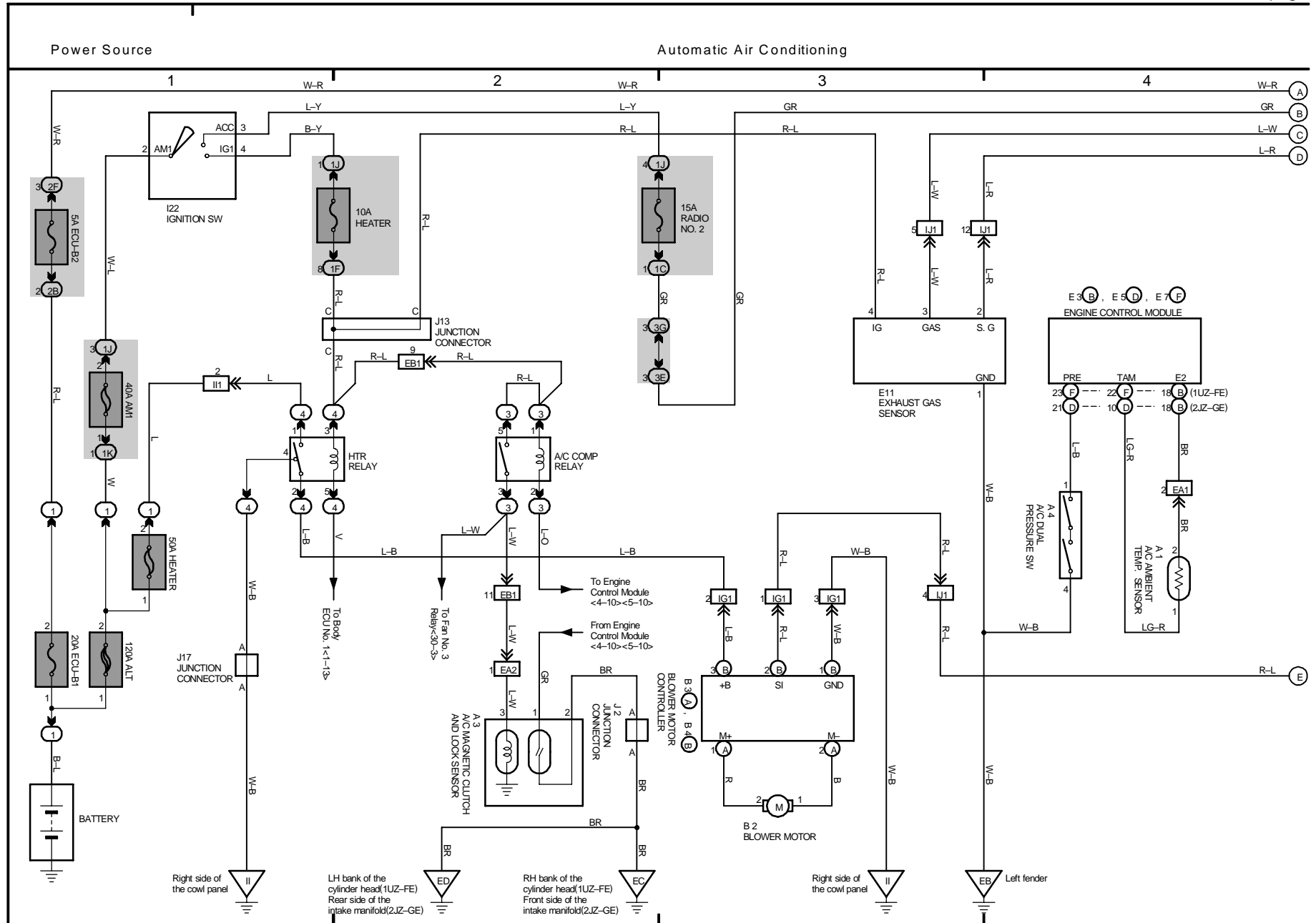

J OVERALL ELECTRICAL WIRING DIAGRAM

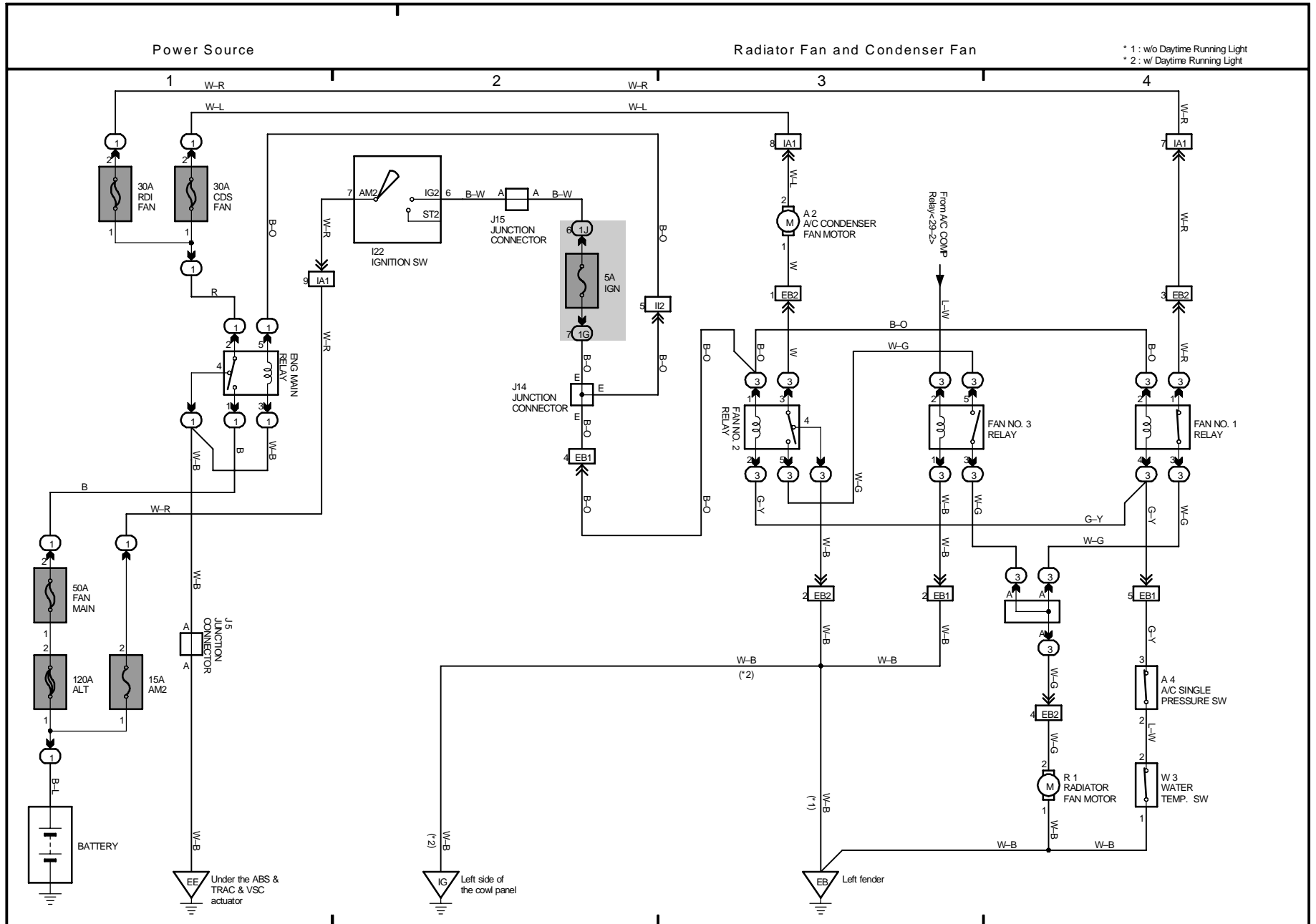

K POWER SOURCE (Current Flow Chart)

The chart below shows the route by which current flows from the battery to each electrical source (Fusible Link, Circuit Breaker, Fuse, etc.) and other parts.

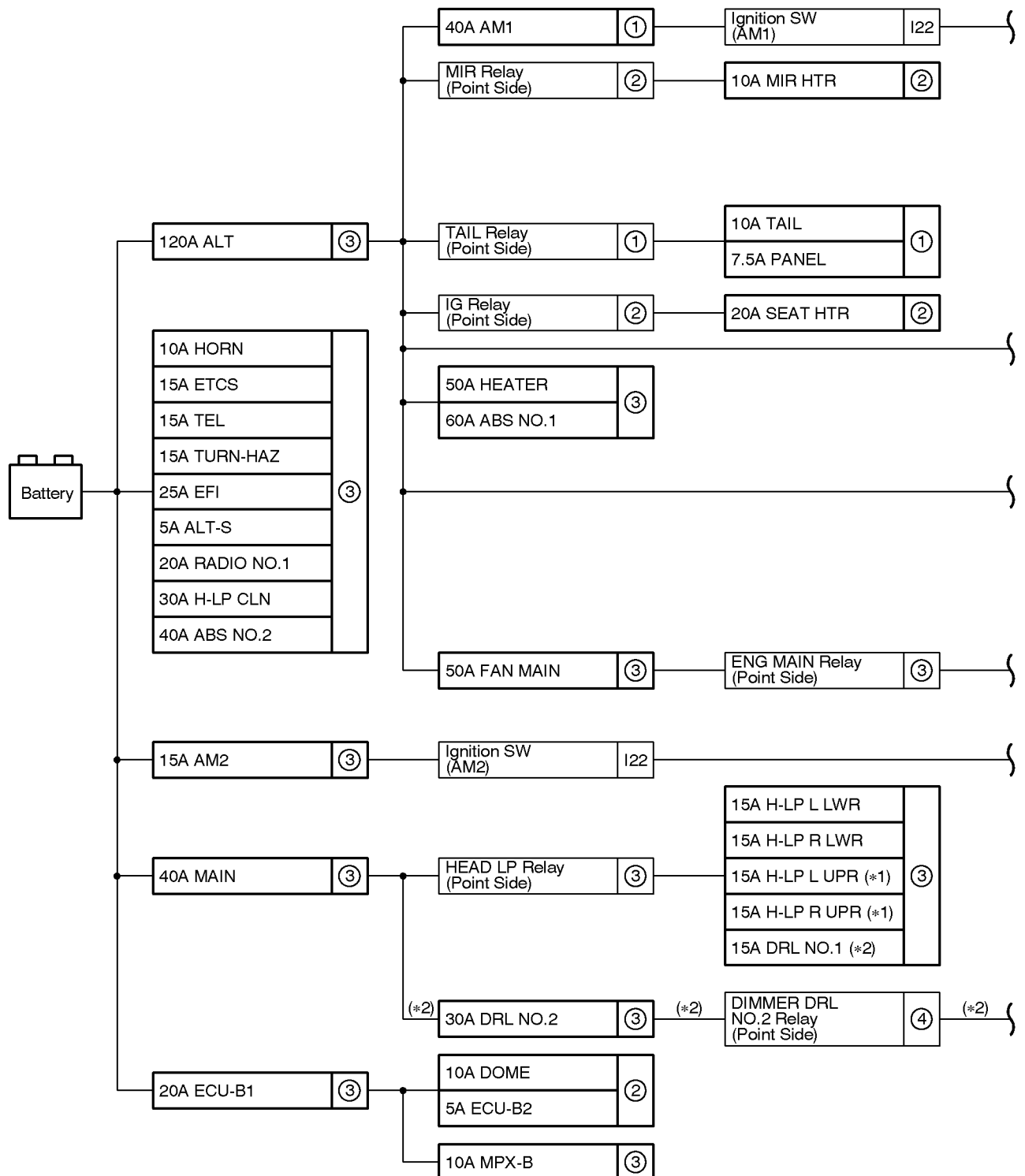

[LOCATION]

① : Driver Side J/B (See page 26)

② : Passenger Side J/B (See page 28)

③ : Engine Room No.1 R/B (See page 22)

④ : Engine Room No.3 R/B (See page 24)

*1 : w/o Daytime Running Light
 *2 : w/ Daytime Running Light

{	15A CIG	①
	15A SRS-ACC	
	15A RADIO NO.2	
	10A HEATER	
	25A WIPER	
	10A GAUGE	
	20A WASHER	
	15A ECU-IG	

{	20A D FR DOOR	①
	20A D RR DOOR	
	30A D P/SEAT	
	15A STOP	
	10A FUEL OPN	
	7.5A OBD	
	5A SRS-B	
	15A FR FOG	

{	30A DEFOG	②
	20A P FR DOOR	
	20A P RR DOOR	
	30A P P/SEAT	
	25A S/ROOF	
	15A TV	

{	30A CDS FAN	③
	30A RDI FAN	

{	5A IGN	①
	5A STARTER	

{ (*2)	15A H-LP L UPR	④
	15A H-LP R UPR	

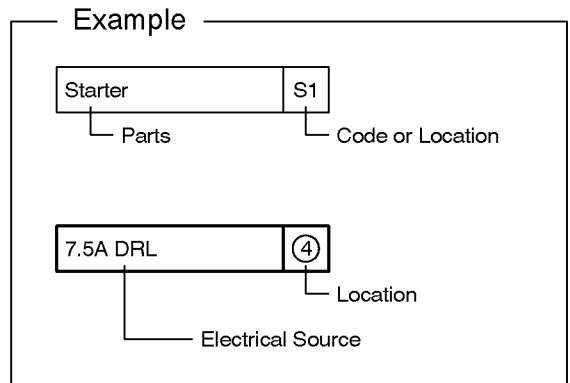

K POWER SOURCE (Current Flow Chart)

Engine Room No.1 R/B (See Page 22)

Fuse		System	Page
5A	ALT-S	Charging	72
10A	H-LP L UPR	Headlight (w/o Daytime Running Light)	114
10A	H LP R UPR	Headlight (w/o Daytime Running Light)	114
10A	HORN	Horn	332
		Multiplex Communication System	152
		Theft Deterrent and Door Lock Control	202
10A	MPX-B	Automatic Light Control	188
		Combination Meter	398
		Interior Light	176
		Key Reminder and Seat Belt Warning	250
		Light Auto Turn Off	192
		Luggage Compartment Door Opener	256
		Multiplex Communication System	152
		Power Seat (Driver's Seat w/ Driving Position Memory)	258
		Power Tilt and Power Telescopic	362
		Power Window	228
		Remote Control Mirror	242
Theft Deterrent and Door Lock Control	202		
Wireless Door Lock Control	216		
10A	TURN-HAZ	Turn Signal and Hazard Warning Light	138
15A	AM2	Engine Control (1UZ-FE)	76
		Engine Control (2JZ-GE)	92
		Starting and Ignition (1UZ-FE)	64
		Starting and Ignition (2JZ-GE)	68
15A	ETCS	Cruise Control (1UZ-FE)	294
		Cruise Control (2JZ-GE)	302
		Engine Control (1UZ-FE)	76
		Engine Control (2JZ-GE)	92
15A	H-LP L LWR	Headlight (w/ Daytime Running Light)	118
		Headlight (w/o Daytime Running Light)	114
15A	H-LP R LWR	Fog Light	124
		Headlight (w/ Daytime Running Light)	118
		Headlight (w/o Daytime Running Light)	114
		Multiplex Communication System	152
15A	TEL	Cellular Mobile Telephone	386
20A	RADIO NO.1	Radio and Player (Except NAKAMICHI)	396
		Radio and Player (NAKAMICHI)	392
25A	EFI	Cruise Control (1UZ-FE)	294
		Cruise Control (2JZ-GE)	302
		Electronically Controlled Transmission and A/T Indicator (1UZ-FE)	274
		Electronically Controlled Transmission and A/T Indicator (2JZ-GE)	284
		Engine Control (1UZ-FE)	76

* These are the page numbers of the first page on which the related system is shown.

Fuse		System	Page
25A	EFI	Engine Control (2JZ-GE)	92
		Engine Immobiliser System (1UZ-FE)	106
		Engine Immobiliser System (2JZ-GE)	110
30A	CDS FAN	Radiator Fan and Condenser Fan	406
30A	DRL NO.1	Headlight (w/ Daytime Running Light)	118
30A	DRL NO.2	Headlight (w/ Daytime Running Light)	118
30A	H-LP CLN	Headlight Cleaner	334
30A	RDI FAN	Radiator Fan and Condenser Fan	406
40A	ABS NO.2	VSC	310
40A	MAIN	Automatic Light Control	188
		Headlight (w/ Daytime Running Light)	118
		Headlight (w/o Daytime Running Light)	114
		Headlight Beam Level Control	338
		Headlight Cleaner	334
		Light Auto Turn Off	192
		Multiplex Communication System	152
		Starting and Ignition (1UZ-FE)	64
		Starting and Ignition (2JZ-GE)	68
		Theft Deterrent and Door Lock Control	202
50A	FAN MAIN	Radiator Fan and Condenser Fan	408
50A	HEATER	Automatic Air Conditioning	412
60A	ABS NO.1	VSC	310
120A	ALT	Automatic Light Control	188
		Charging	72
		Engine Control (1UZ-FE)	76
		Engine Control (2JZ-GE)	92
		Illumination	132
		Light Auto Turn Off	192
		Multiplex Communication System	152
		Radiator Fan and Condenser Fan	408
		Rear Window Defogger and Mirror Heater	378
		Seat Heater	348
		Taillight	126
Theft Deterrent and Door Lock Control	202		

Engine Room No.3 R/B (See Page 24)

Fuse		System	Page
15A	H-LP L UPR	Headlight (w/ Daytime Running Light)	118
15A	H-LP R UPR	Headlight (w/ Daytime Running Light)	118

Driver Side J/B (See Page 26)

Fuse		System	Page
5A	IGN	Cruise Control (1UZ-FE)	294
		Cruise Control (2JZ-GE)	302

* These are the page numbers of the first page on which the related system is shown.

K POWER SOURCE (Current Flow Chart)

Fuse		System	Page
5A	IGN	Electronically Controlled Transmission and A/T Indicator (1UZ-FE)	274
		Electronically Controlled Transmission and A/T Indicator (2JZ-GE)	284
		Engine Control (1UZ-FE)	76
		Engine Control (2JZ-GE)	92
		Radiator Fan and Condenser Fan	408
		SRS	321
		VSC	310
5A	SRS-B	Combination Meter	400
		Headlight (w/o Daytime Running Light)	114
		SRS	321
		Taillight	126
5A	STARTER	Electronically Controlled Transmission and A/T Indicator (1UZ-FE)	274
		Electronically Controlled Transmission and A/T Indicator (2JZ-GE)	284
		Engine Control (1UZ-FE)	76
		Engine Control (2JZ-GE)	92
		Starting and Ignition (1UZ-FE)	64
		Starting and Ignition (2JZ-GE)	68
7.5A	OBD	Engine Control (1UZ-FE)	76
		Engine Control (2JZ-GE)	92
7.5A	PANEL	Illumination	132
10A	FUEL OPN	Fuel Lid Opener	344
10A	GAUGE	Back-Up Light	142
		Charging	72
		Combination Meter	400
		Cruise Control (1UZ-FE)	294
		Cruise Control (2JZ-GE)	302
		Electronically Controlled Transmission and A/T Indicator (1UZ-FE)	274
		Electronically Controlled Transmission and A/T Indicator (2JZ-GE)	284
		Engine Control (1UZ-FE)	76
		Engine Control (2JZ-GE)	92
		Headlight (w/ Daytime Running Light)	118
		Headlight Beam Level Control	338
		Key Reminder and Seat Belt Warning	250
		LEXUS Navigation System	382
		PPS	368
		Shift Lock	358
		Stop Light	146
Taillight	126		
Turn Signal and Hazard Warning Light	138		
VSC	310		
Wiper and Washer	354		
10A	HEATER	Automatic Air Conditioning	412
		Multiplex Communication System	152
		Rear Window Defogger and Mirror Heater	378

* These are the page numbers of the first page on which the related system is shown.

Fuse		System	Page
10A	TAIL	Taillight	126
15A	CIG	Cigarette Lighter and Power Outlet	328
15A	ECU-IG	Auto Antenna	390
		Automatic Glare-Resistant EC Mirror	342
		Automatic Light Control	188
		Cellular Mobile Telephone	386
		Electric Tension Reducer	352
		Headlight Beam Level Control	338
		Interior Light	176
		Key Reminder and Seat Belt Warning	250
		Light Auto Turn Off	192
		Luggage Compartment Door Opener	256
		Moon Roof	372
		Multiplex Communication System	152
		Power Seat (Driver's Seat w/ Driving Position Memory)	258
		Power Tilt and Power Telescopic	362
		Power Window	228
		PPS	368
Remote Control Mirror	242		
Seat Heater	348		
Theft Deterrent and Door Lock Control	202		
VSC	310		
Wireless Door Lock Control	216		
15A	FR FOG	Fog Light	124
		Multiplex Communication System	152
15A	RADIO NO.2	Auto Antenna	390
		Automatic Air Conditioning	412
		Clock	330
		Interior Light	176
		Key Reminder and Seat Belt Warning	250
		LEXUS Navigation System	382
		Light Auto Turn Off	192
		Luggage Compartment Door Opener	256
		Multiplex Communication System	152
		Power Seat (Driver's Seat w/ Driving Position Memory)	258
		Power Tilt and Power Telescopic	362
		Power Window	228
		Radio and Player (Except NAKAMICHI)	396
		Radio and Player (NAKAMICHI)	392
		Remote Control Mirror	242
		Shift Lock	358
Theft Deterrent and Door Lock Control	202		
Wireless Door Lock Control	216		

* These are the page numbers of the first page on which the related system is shown.

K POWER SOURCE (Current Flow Chart)

Fuse		System	Page
15A	SRS-ACC	SRS	321
15A	STOP	Cruise Control (1UZ-FE)	294
		Cruise Control (2JZ-GE)	302
		Electronically Controlled Transmission and A/T Indicator (1UZ-FE)	274
		Electronically Controlled Transmission and A/T Indicator (2JZ-GE)	284
		Engine Control (1UZ-FE)	76
		Engine Control (2JZ-GE)	92
		Multiplex Communication System	152
		Stop Light	146
		VSC	310
20A	D FR DOOR	Automatic Light Control	188
		Interior Light	176
		Key Reminder and Seat Belt Warning	250
		Light Auto Turn Off	192
		Multiplex Communication System	152
		Power Seat (Driver's Seat w/ Driving Position Memory)	258
		Power Tilt and Power Telescopic	362
		Power Window	228
		Remote Control Mirror	242
		Theft Deterrent and Door Lock Control	202
Wireless Door Lock Control	216		
20A	D RR DOOR	Interior Light	176
		Light Auto Turn Off	192
		Multiplex Communication System	152
		Power Window	228
		Theft Deterrent and Door Lock Control	202
		Wireless Door Lock Control	216
20A	WASHER	Headlight Cleaner	334
		Wiper and Washer	354
25A	WIPER	Wiper and Washer	354
30A	D P/SEAT	Multiplex Communication System	152
		Power Seat (Driver's Seat w/ Driving Position Memory)	258
		Power Seat (Driver's Seat w/o Driving Position Memory)	270

Passenger Side J/B (See Page 28)

Fuse		System	Page
5A	ECU-B2	Automatic Air Conditioning	412
		Headlight (w/ Daytime Running Light)	118
		Multiplex Communication System	152
		Power Seat (Driver's Seat w/ Driving Position Memory)	258
10A	DOME	Auto Antenna	390
		Clock	330
		Garage Door Opener	346
		Interior Light	176

* These are the page numbers of the first page on which the related system is shown.

Fuse		System	Page
10A	DOME	Light Auto Turn Off	192
		Multiplex Communication System	152
		Power Window	228
		Radio and Player (Except NAKAMICHI)	394
		Radio and Player (NAKAMICHI)	392
		Theft Deterrent and Door Lock Control	202
		Wireless Door Lock Control	216
10A	MIR HTR	Rear Window Defogger and Mirror Heater	378
15A	TV	LEXUS Navigation System	382
20A	P FR DOOR	Interior Light	176
		Key Reminder and Seat Belt Warning	250
		Light Auto Turn Off	192
		Luggage Compartment Door Opener	256
		Multiplex Communication System	152
		Power Seat (Driver's Seat w/ Driving Position Memory)	258
		Power Tilt and Power Telescopic	362
		Power Window	228
		Remote Control Mirror	242
		Theft Deterrent and Door Lock Control	202
		Wireless Door Lock Control	216
20A	P RR DOOR	Interior Light	176
		Light Auto Turn Off	192
		Multiplex Communication System	152
		Power Window	228
		Theft Deterrent and Door Lock Control	202
		Wireless Door Lock Control	216
20A	SEAT HTR	Seat Heater	348
25A	S/ROOF	Moon Roof	372
30A	DEFOG	Rear Window Defogger and Mirror Heater	378
30A	P P/SEAT	Power Seat (Front Passenger's Seat)	272
		Power Tilt and Power Telescopic	362

* These are the page numbers of the first page on which the related system is shown.

L PART NUMBER OF CONNECTORS

Code	Part Name	Part Number	Code	Part Name	Part Number
A1	A/C Ambient Temp. Sensor	90980-11070	C2	Camshaft Timing Oil Control Valve	90980-11162
A2	A/C Condenser Fan Motor	90980-10928	C3	Camshaft Timing Oil Control Valve LH	
A3	A/C Magnetic Clutch and Lock Sensor	90980-11016	C4	Camshaft Timing Oil Control Valve RH	
A4	A/C Triple Pressure SW (A/C Dual and Single Pressure SW)	90980-10943	C5	Crankshaft Position Sensor (1UZ-FE)	
A5	ABS & TRAC & VSC Actuator	90980-11151		Crankshaft Position Sensor (2JZ-GE)	90980-10947
A6	ABS & TRAC & VSC Actuator	90980-10895	C6	CD Automatic Changer	90980-11923
A7	ABS & TRAC & VSC Actuator	90980-11413	C7	Center Airbag Sensor Assembly	90980-11869
A8	ABS Speed Sensor Front LH	90980-11074	C8	Center Airbag Sensor Assembly	90980-11872
A9	ABS Speed Sensor Front RH		C9	Center Airbag Sensor Assembly	90980-11867
A10	Accelerator Pedal Position Sensor	90980-11150	C10	Cigarette Lighter	90980-11606
A11	Airbag Sensor Front LH	90980-11856	C11	Clock	90980-10799
A12	Airbag Sensor Front RH		C12	Combination Meter	90980-11915
A13	A/C Control Assembly	90980-11392	C13	Combination Meter	90980-11914
A14	A/C Control Assembly	90980-11391	C14	Combination SW	90980-11595
A15	A/C Room Temp. Sensor	90980-10825	C15	Combination SW	90980-11614
A16	A/C Solar Sensor	90980-11053	C16	Combination SW	90980-11616
A17	A/C Thermistor	90980-10825	C17	Combination SW	90980-11594
A18	A/T Shift Position Illumination	90980-11212	C18	Cellular Phone (Hand Set)	90980-10998
A19	ABS & TRAC & VSC ECU	90980-11935	C19	Cellular Phone (Hand Set)	90980-10798
A20	ABS & TRAC & VSC ECU	90980-11476	D1	Data Link Connector 1	90980-11195
A21	ABS & TRAC & VSC ECU	90980-11637	D2	Daytime Running Light Relay No.3	90980-10939
A22	ABS & TRAC & VSC ECU	90980-11638	D3	Daytime Running Light Relay No.4	90980-10940
A23	ABS Deceleration Sensor	90980-11182	D4	Data Link Connector 3	90980-11665
A24	Air Inlet Control Servo Motor	90980-11165	D5	Daytime Running Light Relay (Main)	90980-11450
A25	Air Mix Control Servo Motor (Driver Side)		D6	D/A Converter	90980-11556
A26	Air Mix Control Servo Motor (Front Passenger Side)		D7	Diode (Daytime Running Light)	90980-11251
A27	Air Vent Mode Control Servo Motor		D8	Diode (Luggage Compartment Door Open Detection)	90980-11071
A28	Airbag Squib (Front Passenger Airbag Assembly)	90980-11884	D9	Door Courtesy Light Front LH	90980-11148
A29	Airbag Squib (Steering Wheel Pad)	90980-10850	D10	Door Courtesy Light Front RH	
A30	Automatic Light Control Sensor	90980-11107	D11	Door Courtesy Light Rear LH	
A31	ABS Speed Sensor Rear LH	90980-11060	D12	Door Courtesy Light Rear RH	90980-11156
A32	ABS Speed Sensor Rear RH	90980-11300	D13	Door Courtesy SW Front LH	
A33	Ashtray Illumination Rear LH	-	D14	Door Courtesy SW Front RH	
A34	Ashtray Illumination Rear RH		D15	Door Courtesy SW Rear LH	
A35	Auto Antenna Control Relay and Motor	90980-10799	D16	Door Courtesy SW Rear RH	90980-11013
B1	Brake Fluid Level Warning SW	90980-11009	D17	Door Lock Control SW RH	90980-11858
B2	Blower Motor	90980-10385	D18	Door Lock Motor , Door Key Lock and Unlock SW and Door Lock Detection SW Front LH	
B3	Blower Motor Controller	90980-11579	D19	Door Lock Motor , Door Key Lock and Unlock SW and Door Lock Detection SW Front RH	
B4	Blower Motor Controller	90980-11667	D20	Door Lock Motor and Door Lock Detection SW Rear LH	90980-11150
B5	Body ECU No.1	90980-11877	D21	Door Lock Motor and Door Lock Detection SW Rear RH	90980-11150
B6	Body ECU No.2		D22	Driver Door ECU	90980-11595
B7	Buckle SW LH	90980-11399			
B8	Buckle SW RH				
C1	Camshaft Position Sensor	90980-10947			

Note: Not all of the above part numbers of the connector are established for the supply. In case of ordering a connector or terminal with wire, please confirm in advance if there is supply for it using "Parts Catalog News" (published by Parts Engineering Administration Dept.).

Code	Part Name	Part Number	Code	Part Name	Part Number
D23	Driver Door ECU	90980-11648	H6	Headlight Control ECU LH	90980-11255
D24	Driver Door ECU	90980-11594	H7	Headlight Control ECU RH	
D25	Driving Position Memory SW	90980-11165	H8	Headlight LH (High)	90980-11095
D26	Daytime Running Light Resistor or Short Connector	90980-10928	H9	Headlight LH (Low)	90980-11096
			H10	Headlight RH (High)	90980-11095
E1	Electronically Controlled Transmission Solenoid	90980-11151	H11	Headlight RH (Low)	90980-11096
E2	Engine Control Module	90980-11421	H12	Heated Oxygen Sensor (Bank 1 Sensor 1) (1UZ-FE)	90980-10869
E3	Engine Control Module	90980-11476		Heated Oxygen Sensor (Bank 1 Sensor 1) (2JZ-GE)	90980-11028
E4	Engine Control Module	90980-11586	H13	Heated Oxygen Sensor (Bank 1 Sensor 2)	
E5	Engine Control Module	90980-11637	H14	Heated Oxygen Sensor (Bank 2 Sensor 1)	90980-10869
E6	Engine Control Module	90980-11638	H15	Height Control Sensor (Front)	90980-11929
E7	Engine Control Module	90980-11423	H16	Horn LH	90980-10619
E8	Engine Coolant Temp. Sensor	90980-10736	H17	Horn RH	
E9	Engine Hood Courtesy SW	90980-11189	H18	Hazard SW	90980-10801
E10	Engine Oil Level Sensor	90980-11235	H19	Headlight Cleaner SW	90980-10797
E11	Exhaust Gas Sensor	90980-10831	H20	Heated Oxygen Sensor (Bank 1 Sensor 2)	90980-11028
E12	Electronically Controlled Transmission Pattern Select SW	90980-11165	H21	Heated Oxygen Sensor (Bank 2 Sensor 2)	
F1	Front Fog Light LH	90980-11096	H22	Height Control Sensor (Rear)	90980-11298
F2	Front Fog Light RH				
F3	Front Side Marker Light LH	90980-11162	H23	High Mounted Stop Light (Bulb)	90980-10908
F4	Front Side Marker Light RH				
F5	Front Turn Signal and Parking Light LH	90980-10942	H24	High Mounted Stop Light (LED)	90980-11368
F6	Front Turn Signal and Parking Light RH				
F7	Front Wiper Motor	90980-11599	I1	Igniter	90980-11653
F8	Fuel Lid Opener SW	90980-10825	I2	Ignition Coil and Igniter No.1	90980-11150
F9	Front Door Speaker LH	90980-10935	I3	Ignition Coil and Igniter No.2	
F10	Front Door Speaker RH				
F11	Front Passenger Door ECU	90980-11594	I4	Ignition Coil and Igniter No.3	
F12	Front Passenger Door ECU	90980-11648	I5	Ignition Coil and Igniter No.4	
F13	Front Passenger Door ECU	90980-11595	I6	Ignition Coil and Igniter No.5	
F14	Fuel Lid Opener Motor	90980-11150	I7	Ignition Coil and Igniter No.6	
F15	Fuel Pump and Sender	90980-11077	I8	Ignition Coil and Igniter No.7	
F16	Fuel Pump Control ECU	90980-10862	I9	Ignition Coil and Igniter No.8	90980-11246
F17	Fuel Sender (Sub)	90980-11140	I10	Ignition Coil No.1	
G1	Generator	-	I11	Ignition Coil No.2	
G2	Generator	90980-11349	I12	Ignition Coil No.3	90980-11153
G3	Glove Box Light	90980-11148	I13	Injector No.1	
G4	Glove Box Light SW	90980-11098	I14	Injector No.2	
G5	Garage Door Opener	90980-11212	I15	Injector No.3	
H1	Headlight Beam Level Control ECU	90980-10897	I16	Injector No.4	
H2	Headlight Beam Level Control ECU	90980-10891	I17	Injector No.5	
H3	Headlight Beam Level Control Motor	90980-11144	I18	Injector No.6	
H4	Headlight Cleaner Control Relay	90980-10939	I19	Injector No.7	
H5	Headlight Cleaner Motor	90980-11410	I20	Injector No.8	90980-10906
			I21	Ignition Key Cylinder Light	
			I22	Ignition SW	
			I23	Inner Mirror	90980-11186

L PART NUMBER OF CONNECTORS

Code	Part Name	Part Number	Code	Part Name	Part Number
I24	Interior Light Rear LH	90980-11187	M7	Mirror Retractor SW	90980-11090
I25	Interior Light Rear RH	90980-11187	N1	Noise Filter (Ignition)	90980-10843
J1	Junction Connector	90980-10803	N2	Navigation ECU	90980-11542
J2	Junction Connector	90980-11542	N3	Navigation ECU	90980-10799
J3	Junction Connector	90980-11661	N4	Noise Filter (High Mounted Stop Light)	90980-11094
J4	Junction Connector		N5	Noise Filter (Rear Window Defogger)	90980-11259
J5	Junction Connector	90980-10803	N6	Noise Filter (Stop Light)	90980-10916
J6	Junction Connector	90980-10976	O1	O/D Direct Clutch Speed Sensor	90980-11156
J7	Junction Connector	90980-11542	O2	Oil Pressure SW	90980-11363
J8	Junction Connector	90980-11398	P1	Park/Neutral Position SW	90980-11332
J9	Junction Connector	90980-11915	P2	Power Steering Oil Pressure SW	90980-10974
J10	Junction Connector	90980-11542	P3	PPS Solenoid	90980-11003
J11	Junction Connector		P4	Parking Brake SW	90980-10871
J12	Junction Connector	90980-10803	P5	Power Outlet	90980-10760
J13	Junction Connector	90980-11915	P6	PPS ECU	90980-10797
J14	Junction Connector		P7	Personal Light	90980-11187
J15	Junction Connector	90980-11542	P8	Power Window Control SW Front RH	90980-10797
J16	Junction Connector	90980-11539	P9	Power Window Control SW Rear LH	
J17	Junction Connector	90980-10803	P10	Power Window Control SW Rear RH	
J18	Junction Connector	90980-11542	P11	Power Window Master SW	90980-11469
J19	Junction Connector		P12	Power Window Motor Front LH	90980-11011
J20	Junction Connector	90980-10976	P13	Power Window Motor Front RH	
J21	Junction Connector	90980-11398	P14	Pretensioner LH	90980-11862
J22	Junction Connector	90980-10976	P15	Pretensioner RH	
J23	Junction Connector	90980-10803	P16	Power Seat Control SW (Driver's Seat)	90980-10997
J24	Junction Connector		P17	Power Seat Control SW (Front Passenger's Seat)	
K1	Knock Sensor 1	90980-11166	P18	Power Seat ECU	90980-11527
K2	Knock Sensor 2		P19	Power Seat ECU	90980-11502
L1	Luggage Compartment Door Opener SW	90980-10860	P20	Power Seat Motor (Driver's Seat Front Vertical Control)	90980-10825
L2	License Plate Light LH	90980-11148	P21	Power Seat Motor (Driver's Seat Lumbar Support Control)	
L3	License Plate Light RH		P22	Power Seat Motor (Driver's Seat Rear Vertical Control)	
L4	Light Failure Sensor	90980-10803	P23	Power Seat Motor (Driver's Seat Reclining Control)	
L5	Luggage Compartment Door Courtesy SW and Opener Motor	90980-10825	P24	Power Seat Motor (Driver's Seat Slide Control)	
L6	Luggage Compartment Door Key Unlock SW	90980-11212	P25	Power Seat Motor (Front Passenger's Seat Front Vertical Control)	
L7	Luggage Compartment Light	90980-11148	P26	Power Seat Motor (Front Passenger's Seat Lumbar Support Control)	
L8	Lumbar Support Control SW (Driver's Seat)	90980-10601	P27	Power Seat Motor (Front Passenger's Seat Rear Vertical Control)	
L9	Lumbar Support Control SW (Front Passenger's Seat)		P28	Power Seat Motor (Front Passenger's Seat Reclining Control)	
M1	Mass Air Flow Meter	90980-11317			
M2	Master Cylinder Pressure Sensor	90980-10845			
M3	Multi-Display	90980-11562			
M4	Multi-Display	90980-11475			
M5	Moon Roof Control ECU	90980-10997			
M6	Moon Roof Control SW	90980-11488			

Note: Not all of the above part numbers of the connector are established for the supply. In case of ordering a connector or terminal with wire, please confirm in advance if there is supply for it using "Parts Catalog News" (published by Parts Engineering Administration Dept.).

Code	Part Name	Part Number	Code	Part Name	Part Number
P29	Power Seat Motor (Front Passenger's Seat Slide Control)	90980-10825	S15	Stereo Component Amplifier	90980-11591
P30	Power Seat Position Sensor (Driver's Seat Front Vertical Control)	90980-10296	S16	Stereo Component Amplifier	90980-11542
P31	Power Seat Position Sensor (Driver's Seat Rear Vertical Control)	90980-10908	S17	Stereo Component Amplifier	90980-11535
P32	Power Seat Position Sensor (Driver's Seat Reclining Control)		S18	Seat Belt Warning Occupant Detection Sensor	90980-10860
P33	Power Seat Position Sensor (Driver's Seat Slide Control)		S19	Seat Heater (Driver's Seat Back)	90980-10825
R1	Radiator Fan Motor		90980-10928	S20	
R2	Radio and Player	90980-10996	S21	Seat Heater (Front Passenger's Seat Back)	
R3	Radio and Player	90980-10997	S22	Seat Heater (Front Passenger's Seat Cushion)	
R4	Radio and Player (Except NAKAMICHI)	90980-11165	S23	Side Airbag Squib LH	90980-11864
	Radio and Player (NAKAMICHI)	90980-10803	S24	Side Airbag Squib RH	
R5	Radio and Player	90980-10799	T1	Theft Deterrent Horn	90980-10619
R6	Remote Control Mirror SW	90980-11657	T2	Throttle Control Motor	90980-10942
R7	Rheostat	90980-11165	T3	Throttle Position Sensor (1UZ-FE)	90980-11037
R8	Rear Combination Light LH	90980-11587		Throttle Position Sensor (2JZ-GE)	90980-10711
R9	Rear Combination Light LH	90980-11399	T4	Telephone Microphone	90980-11369
R10	Rear Combination Light RH	90980-11587	T5	Tilt and Telescopic ECU	90980-10801
R11	Rear Combination Light RH	90980-11399	T6	Transponder Key Amplifier	90980-10933
R12	Rear Door LH ECU	90980-11877	T7	Turn Signal Flasher	90980-10799
R13	Rear Door RH ECU		T8	Telephone Transceiver and Speaker Relay	90980-10802
R14	Rear Door Speaker LH	90980-10935	T9	Telephone Transceiver and Speaker Relay	90980-10803
R15	Rear Door Speaker RH		T10	Tension Reducer Solenoid LH	90980-11369
R16	Remote Control Mirror LH (w/ Driving Position Memory)	90980-11590	T11	Tension Reducer Solenoid RH	
	Remote Control Mirror LH (w/o Driving Position Memory)	90980-10798	U1	Unlock Warning SW and Key Interlock Solenoid	90980-10795
R17	Remote Control Mirror RH (w/ Driving Position Memory)	90980-11590	V1	Vehicle Speed Sensor (Electronically Controlled Transmission)	90980-11156
	Remote Control Mirror RH (w/o Driving Position Memory)	90980-10798	V2	VSV (ACIS) (1UZ-FE)	
S1	Starter	90980-11400	V2	VSV (ACIS) (2JZ-GE)	90980-11149
S2	Starter	-	V3	VSV (EVAP)	90980-11156
S3	Seat Heater SW	90980-10797	V4	VVT Sensor LH	90980-10947
S4	Shift Lock Control ECU	90980-11450	V5	VVT Sensor RH	
S5	Step Light LH	-	V6	VSC Off SW	90980-11494
S6	Step Light RH		V7	VSC Warning Buzzer	90980-10906
S7	Stereo Component Amplifier	90980-10803	V8	Vanity Light LH	90980-11369
S8	Stereo Component Amplifier	90980-10799	V9	Vanity Light RH	
S9	Stereo Component Amplifier	90980-10997	V10	Vapor Pressure Sensor	90980-11860
S10	Stereo Component Amplifier	90980-10996	V11	VSV (Vapor Pressure Sensor)	90980-11859
S11	Stop Light SW	90980-11118	W1	Washer Level Warning SW	90980-11068
S12	Side Airbag Sensor LH	90980-11857	W2	Washer Motor	90980-10981
S13	Side Airbag Sensor RH		W3	Water Temp. SW	90980-11235
S14	Stereo Component Amplifier	90980-11556	W4	Wireless Door Lock Buzzer	90980-11156
			W5	Wireless Door Lock Control ECU	90980-11165
			W6	Woofer (Speaker)	90980-10825
			Y1	Yaw Rate Sensor	90980-11904